

QUILTING WITH THE Z44

CONTENTS

Parts List.....	3
Care of the Z44.....	2
Warranty.....	2
Assembly	
Base Leg to Stand.....	5
Stand to Tilt Head.....	6
Carriage Bolt to End.....	7
Tilt head to end.....	8
Brace Assembly.....	8
Brace to Stand.....	11
Pole Assembly.....	12
Cog Wheel assembly.....	14
Tuning Up the Z44.....	14
Lamp Holding Bracket.....	15
Assembly of accessories	
Super King extension assembly.....	16
Extra-Long pole assembly.....	16
Edgemaster I/M application.....	16
Folding the Z44.....	17
Tilting the Z44.....	18
Making and using cloth leaders.....	19
Quilting instructions.....	21
Trouble shooting.....	25
Addresses and phone numbers.....	2

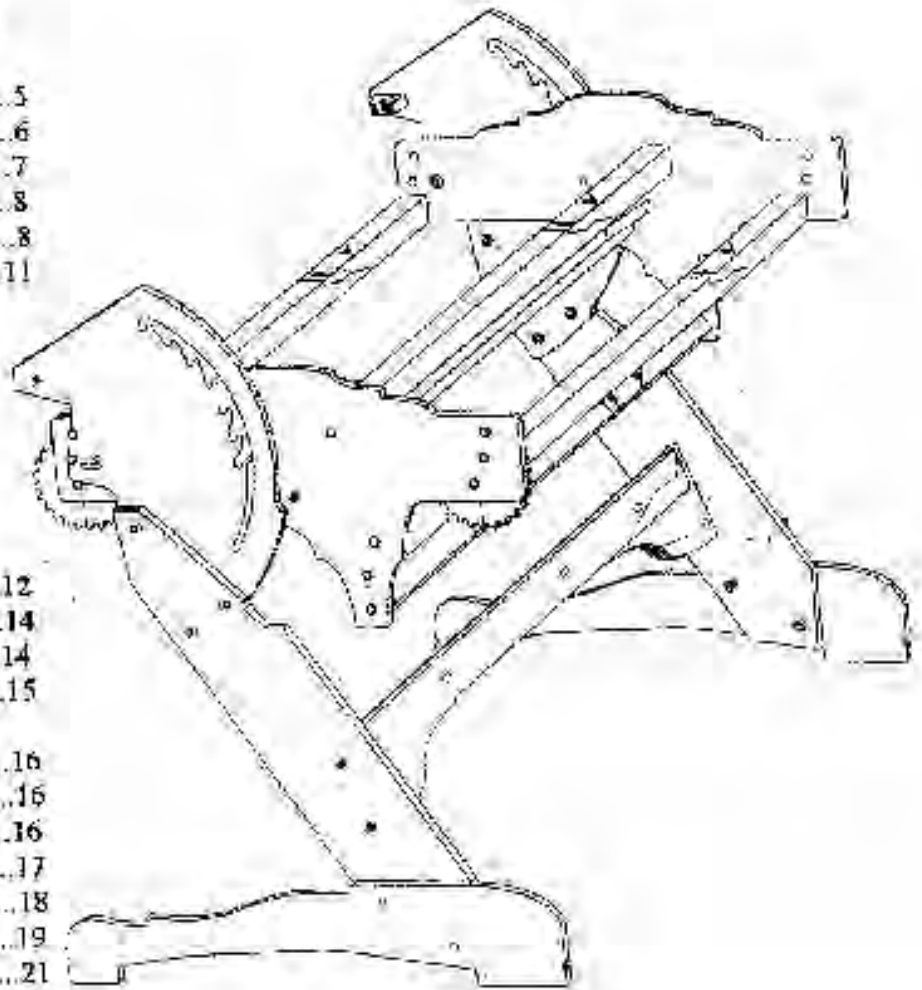

PATENT PENDING

Copyright July 1996 Jim M. Bagley, GraceWood, Inc.
Reproduction Prohibited.

Care of Your GraceFrame™

The frame may be sealed and/or stained with an application of tung oil which will help preserve the wood and will help to prevent warping. To add a certain color to your frame, you may use a Danish Oil. We recommend the Dett™ or Watco™ brands. For a smoother finish, we also recommend using a very fine grit sand paper (wet/dry sandpaper) to rub in your first coat. Test stain on an inconspicuous place. Many different finishes and/or stains may be suitable for sealing and beautifying your GraceFrame™. You may want to consult your local paint retailer for finishes which will apply easily and dry hard, not oily.

TIPS

- Store frame in a dry place—preferably with poles and braces in vertical position if not assembled.
- Do not carry the frame by the quilting poles.
- Do not drop the frame or let it twist out of square.

GraceFrame™ Lifetime Limited Warranty

We will replace any part that fails to work for any reason other than loss or intentional damage by the purchaser. This simply means that "if it breaks, we will fix it." The faulty part must be returned to The Grace Company, freight prepaid, and we will repair or replace it at our discretion. Your Grace Quilting Frame will be warranted as long as GraceWood, Inc. is still operating as a business (hopefully forever). Any broken or damaged part must be sent, postage prepaid to the Grace Company before proper replacement can be made.

For correspondence concerning your GraceFrame™, write to:
The Grace Company
P.O. Box 27823
Salt Lake City, UT 84127

For shipping of materials to the Grace Co. address package (postage prepaid) to:
The Grace Company 801 West Layton Ave. Salt Lake City, UT 84104

For technical support, call (801)972-5804. All calls will be returned.

Please send us your comments or suggestions to the following:
FAX: (801)-908-8888 E-Mail: info@graceframe.com <http://www.graceframe.com>

About the Grace Quilting Frame

The Grace Quilting System has been developed over the past decade with several original design innovations. Due to feed back from many of the thousands of quilters who have purchased and do use the GraceFrame™ we have been able to make a frame that will truly enhance the entire process of hand quilting from beginning to end. If you have any suggestions that will help us to improve our product or service, please write to The Grace Company. *Thank You and Happy Quilting!*

We have included a new tool for your convenience in assembling and disassembling your Grace Quilting Frame/Hoop. This WingGrip™ tool has two openings at different angles. Simply fit it over the wing nut and turn to tighten. With this tool, you can easily tighten a wing nut slightly more than by hand! [Be careful not to overtighten].



Z44 Parts

1- #LE28Z44
Left End - 4 Rail Model

1- #RE28Z44
Right End - 4 Rail Model
Metal Inserts

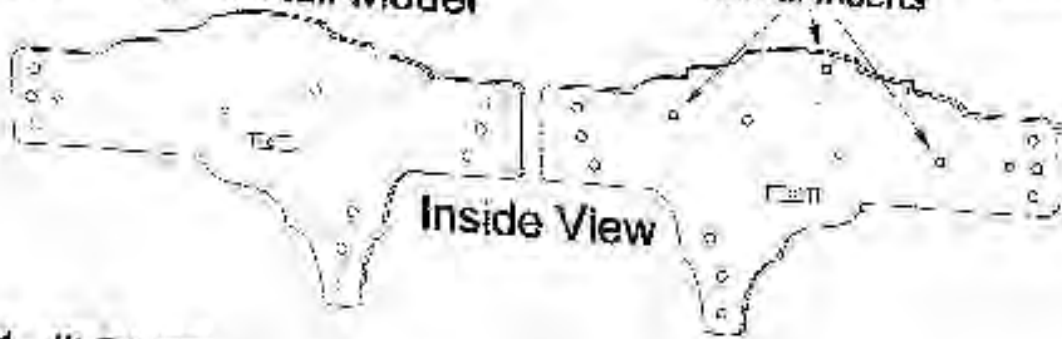

1- #LTH7Z
Left Tilt Head

1- #RTH7Z
Right Tilt Head

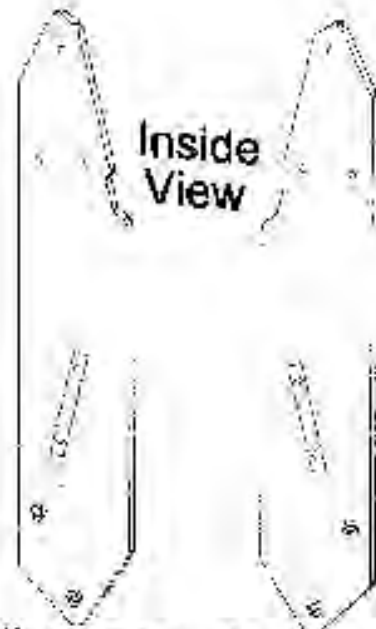
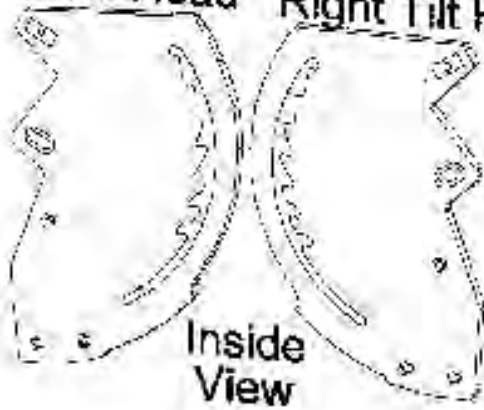

2- #BL30Z Base Leg

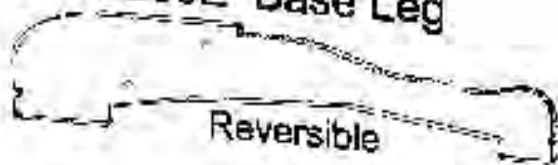

1- #LSL33Z 1- #RSL33Z
Left & Right Z Stand Legs

2- #UPBR595Z Upper Brace

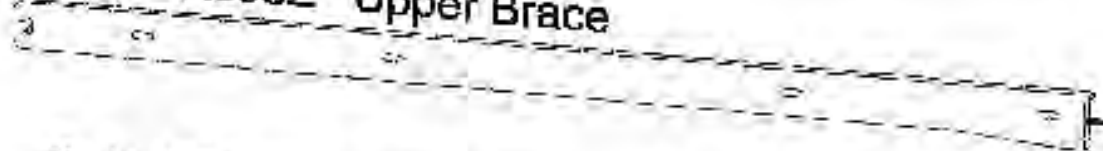

2- #LOBR62Z Lower Brace

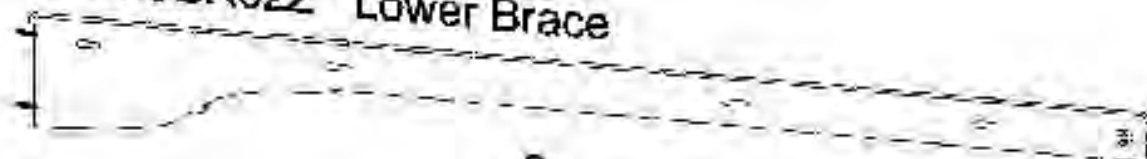

- 8- 5/16" (Smaller) Wing Nuts
- 2- 3/8" Nuts
- 4- 3/8" x 1-1/2" (Largest) Flat Washer
- 6- 3/16" (Larger) Flat Washer
- 8- 7/8" x 2" Plastic Flat Washer
- 4- 3/8" (Larger) Wing Nuts
- 4- 3/8" x 2" Carriage Bolts
- 8- 5/16" x 1-1/2" (Larger) Hex Head Bolts
- 8- 1/4" (Smaller) Flat Washer
- 6- 5/16" x 1-3/4" Optional Wing Head Bolts Replaces The 5/16" x 1-1/2" (Larger) Hex Head Bolts
- 25- 1/4" x 1-1/2" (Smaller) Hex Head Bolts

- 2- #LH212Z Reversible Lip Holding Bracket
- 4- #PL48-5Z Spring End Pole D
- 2- #C9R315Z Wood Cog Wheel or Catcher
- 3- #CW626Z Reversible Wood Cog Stop or Pawl

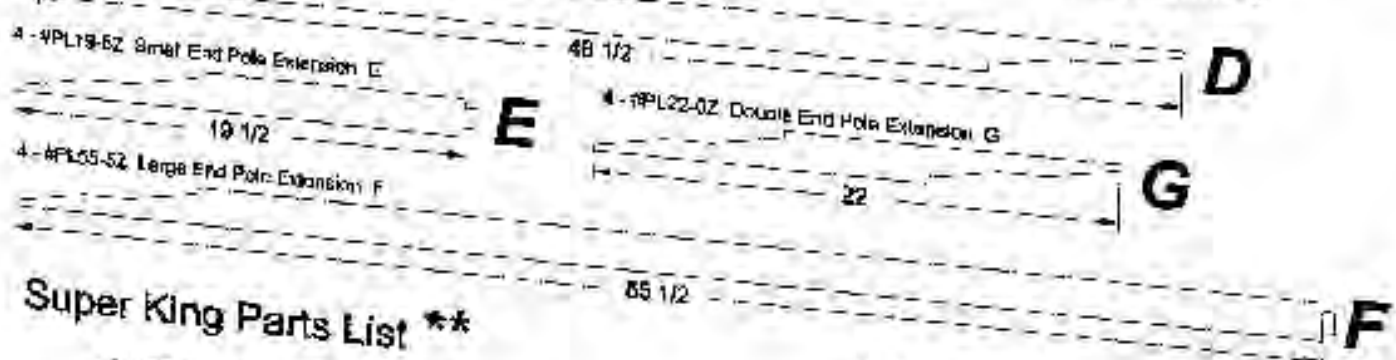

Super King Parts List **

- 4- #PL22-0Z Double End Pole Extension G
- 8- 1/4" x 1-1/2" (Smaller) Hex Head Bolts
- 4- 5/16" x 1-1/2" (Larger) Hex Head Bolts
- 8- 1/4" (Smaller) Flat Washer
- 4- 5/16" (Larger) Flat Washer

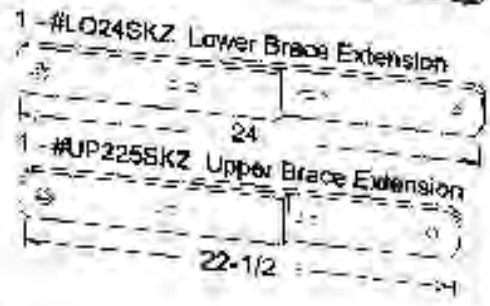

Extra Long Super King Parts List **

- 8- 1/4" x 1-1/2" (Smaller) Hex Head Bolts
- 4- 5/16" x 1-1/2" (Larger) Hex Head Bolts
- 8- 1/4" (Smaller) Flat Washer
- 4- 5/16" (Larger) Flat Washer

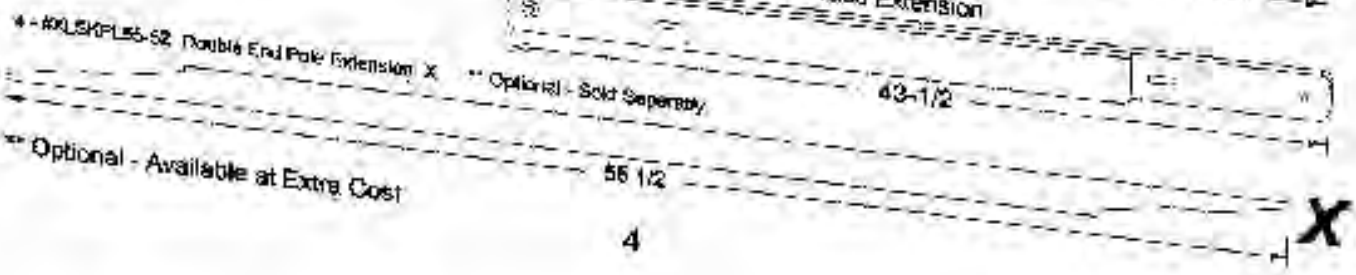
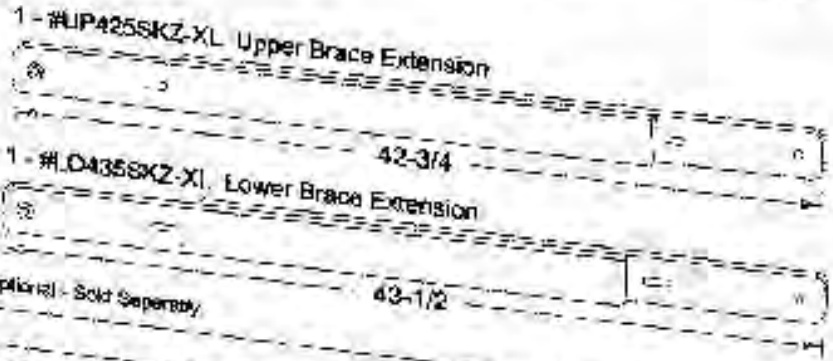

** Optional - Available at Extra Cost

Assembly of Quilting Frame

Unpacking

Using the part list as a reference, take **all** of the parts out of the box and make sure that you have all the parts. If there is something missing or broken contact The Grace Company. We will promptly ship any needed item.

Tools

To assemble the Grace Frame you will need a few common tools. Once the frame is assembled, no tools will be needed for the utilization of the frame.

- 1 One 9/16" combination wrench or adjustable wrench (like a crescent wrench).
- 2 One pair of slip joint pliers
- 3 One 7/16" wrench or socket wrench.
- 4 One 1/2" wrench or socket wrench.

Section 1. Base leg to Stand Assembly

Parts need: 2 each Base leg (#BL30Z)

1 each right Stand Leg (#RSL33Z)

1 each left Stand Leg (#LSL33Z)

4 each 1/4" flat washer (smaller washer)

4 each 5/16" X 1 1/2" hex head bolt (larger hex-head bolt)

Step 1

Lay **Stand** part on floor with metal inserts (called T-Nuts) facing the floor.

Step 2

Position base part over **Stand** part lining up the bolt holes on both parts.

Step 3

By hand, insert Hex-head bolts through flat washers and into holes.

Tighten bolts through the wood holes and into T-Nuts.

Step 4

Make sure all four bolts have been started into the threads of the metal insert before tightening with the wrench. Completely tighten bolts until firmly adjusted, however do not over tighten or strip bolts threads.

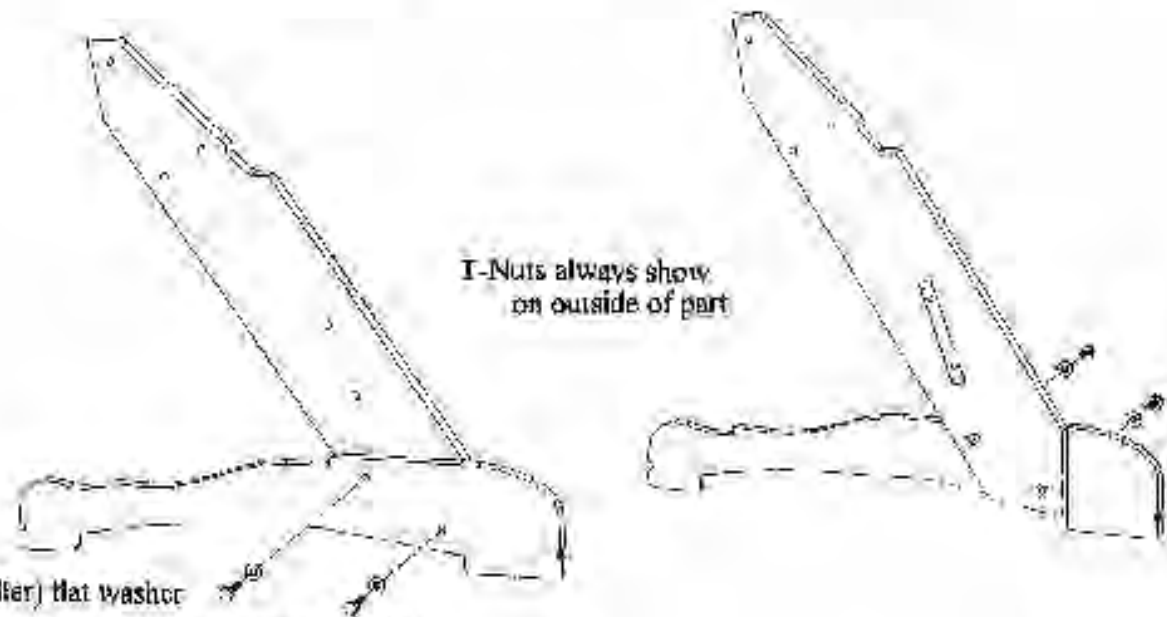

T-Nuts always show
on outside of part

1/4" (smaller) flat washer

5/16" X 1 1/2" Hex-head bolts or winged bolt

Section 2. Stand to Tilt Head Assembly

- Parts needed: 2 each Stand with Base leg adjoined
1 each left Tilt Head (#LTH7Z)
1 each right Tilt Head (#RTH7Z)
6 each 1/4" washer (smaller washer)
6 each 1/4" X 1 1/2" Hex-head bolt (smaller hex-head bolt)

- Step 1. Position Tilt Head parts with metal inserts (called T-Nuts) facing the floor
- Step 2. Position the Stand part directly on top of the Tilt Head. Line the three bolts up. Line up the parts matching the edges of wood.
- Step 3. Place the bolts through the washers and into the bolt holes. By hand, start each bolt through each hole and into the threads of the T-Nut.
- Step 4. Using socket wrench, completely tighten the hex-head bolts until firmly adjusted.

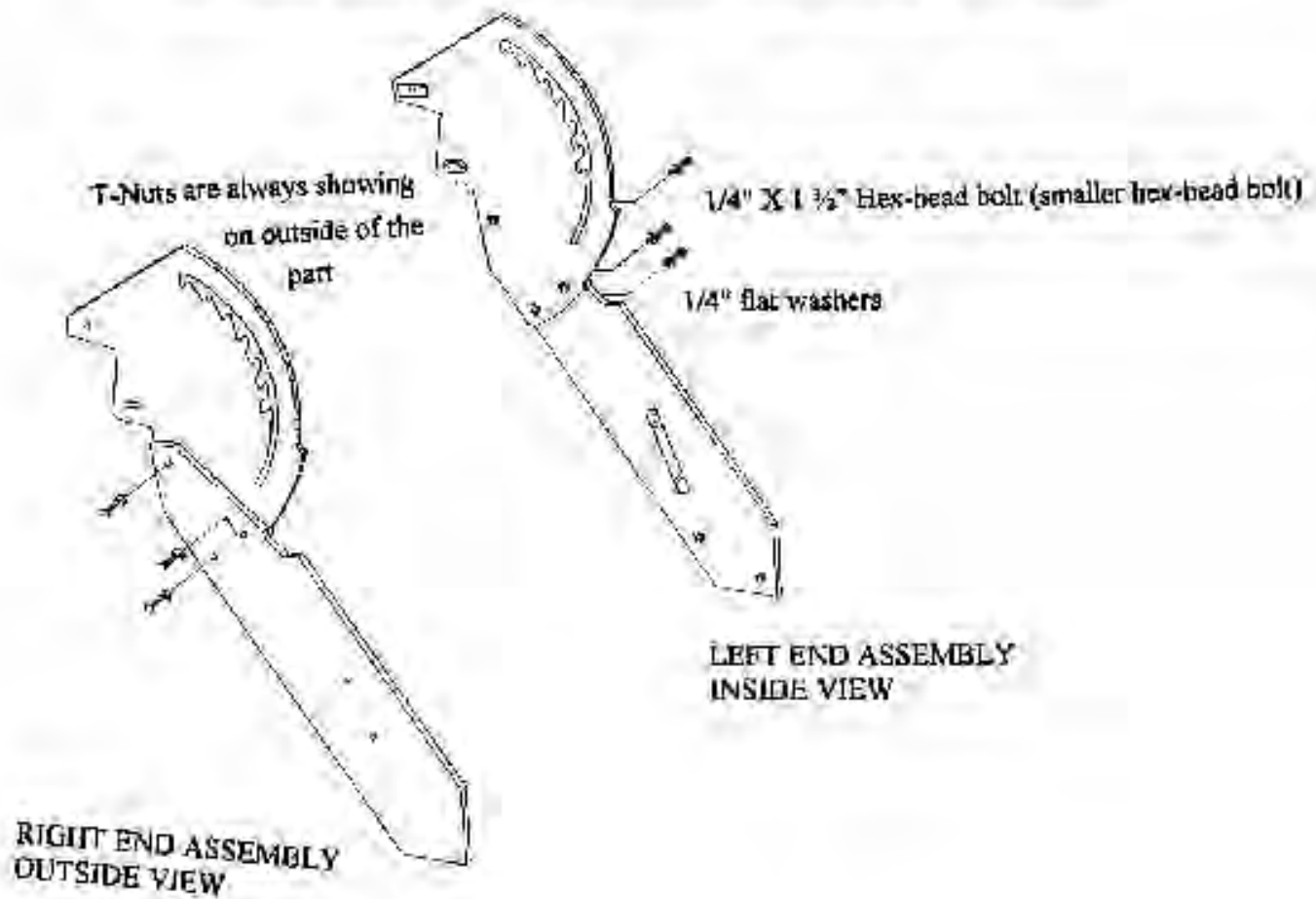

Section 3. Carriage Bolt to End Assembly

Parts Needed: *1 each 3/8" x 2" carriage bolt*
 2 each 5/16" flat washer
 2 each 3/8" hex-Nut

Step 1.

Insert carriage bolt through holes as indicated in pictures. Threads come through in the outside view. Heads of carriage bolts are on the inside of the part. Make sure that you are inserting them correctly from the inside of the end board.

Step 2.

Thread the carriage bolts through the tight hole carefully until the head of the carriage bolt is very close to the wood. (To help you draw in the carriage bolt heads through the holes in the center of the pieces, you may place a washer and nut on them and tighten them to pull them in. Then remove the washer and nut).

Step 3.

Place a 5/16" (larger flat) washer and then a 3/8" nut onto the end of the protruding bolt as indicated on picture. Notice that only the front bolt on each end board is attached to the washer/hex-nut at this point.

Step 4.

Position the end board so that the tips of carriage bolts are protruding upwards.

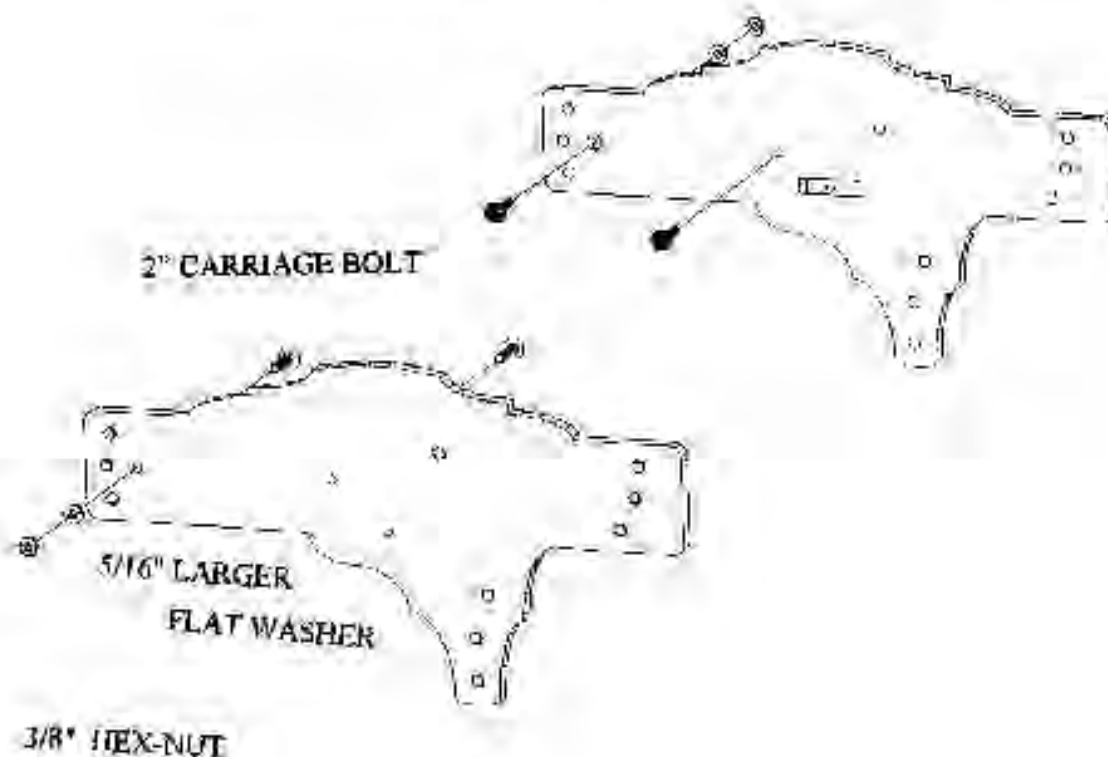

Section 4. Tilt Head to End Assembly

Parts needed: 2 each end board with carriage bolts installed.
4 each 3/8" wing nut
4 each 3/8" X 1 1/2" washers
2 each assembled Base/Stand/Tilt head pieces

Step 1.

End boards should have been placed with carriage bolts protruding upwards as directed in step 4 of Section 3.

Step 2.

Position the Tilt head piece (as shown in picture) on top of the end board. Allow the carriage bolts to be positioned as shown in the picture.

Step 3.

Place a 3/8" washer (larger) around each protruding bolt and then place a 3/8" wing nut on the bolt.

Step 4.

Tighten the wing nut by hand until the wing nuts are firmly in position and the carriage bolt is firmly seated in the wood.

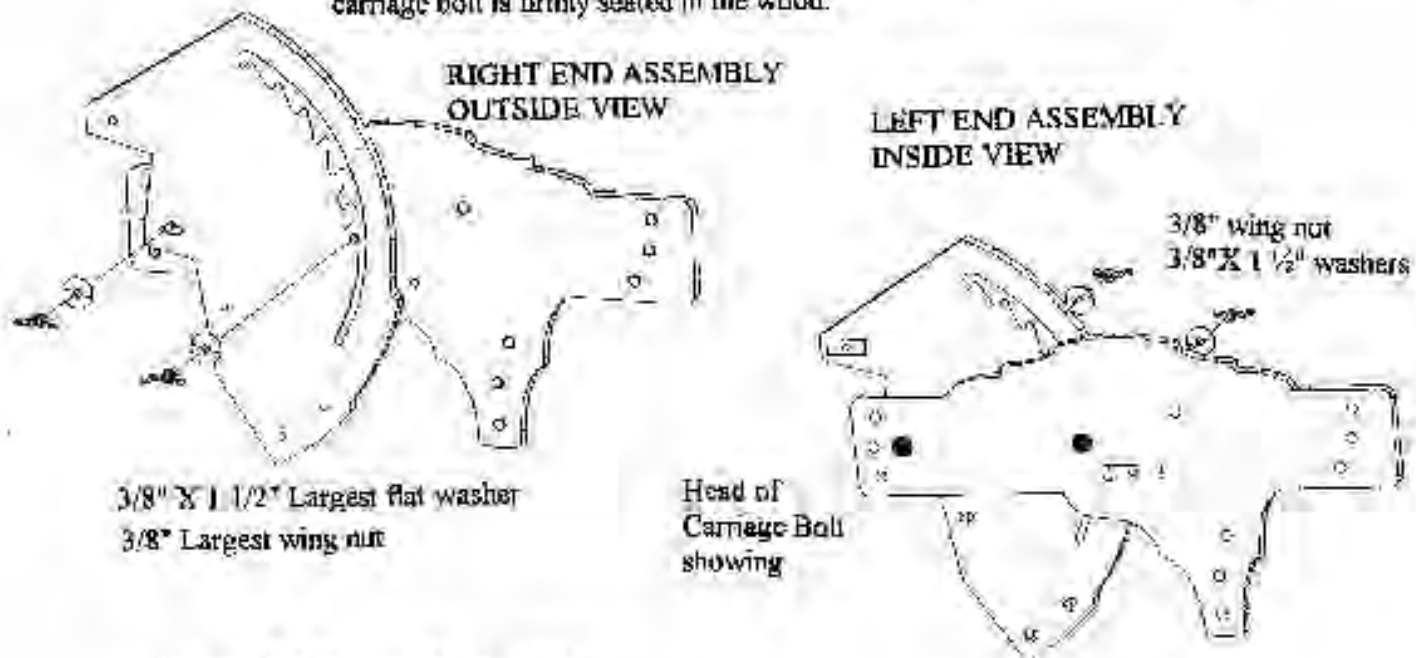

Section 5. Brace Assembly

Parts needed: 2 each Upper brace (#UPBR595Z)
2 each Lower brace (#LOBR627)
4 each 5/16" X 1 1/2" Hex-head bolt (larger)
4 each 5/16" Washer (Larger)

*****NOTE: T-NUTS ALWAYS FACE OUTSIDE AND ARE VISIBLE AFTER ASSEMBLY IS COMPLETE. REMEMBER THIS TIP THROUGHOUT THE BRACE ASSEMBLY STEPS*****

Brace Assembly

T-NUTS OUTSIDE AND VISIBLE

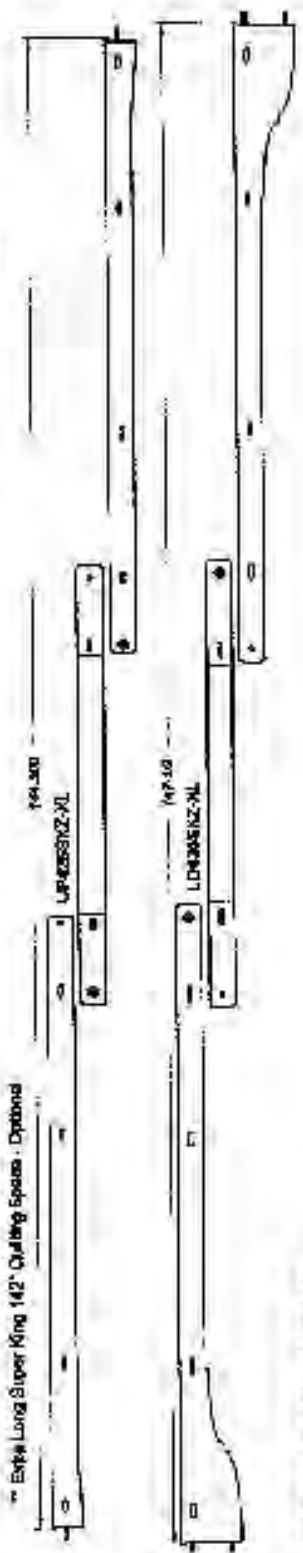
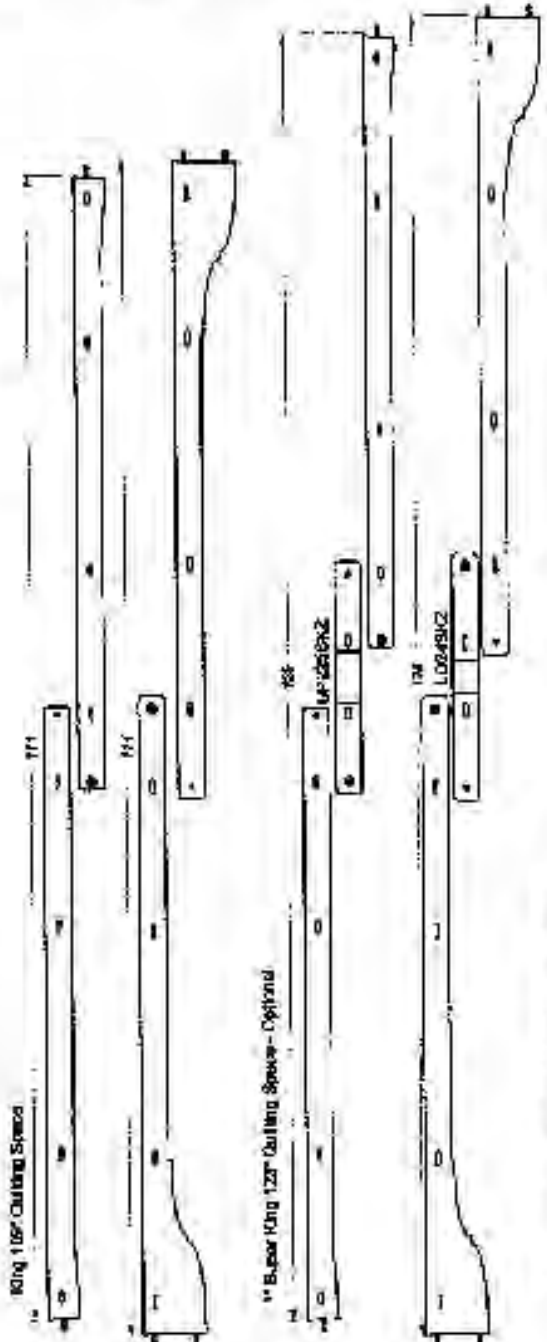
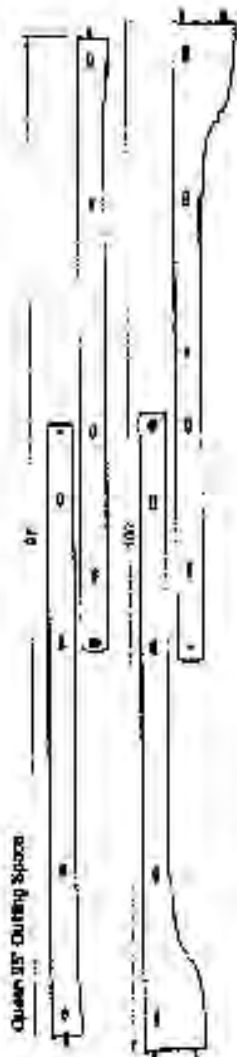
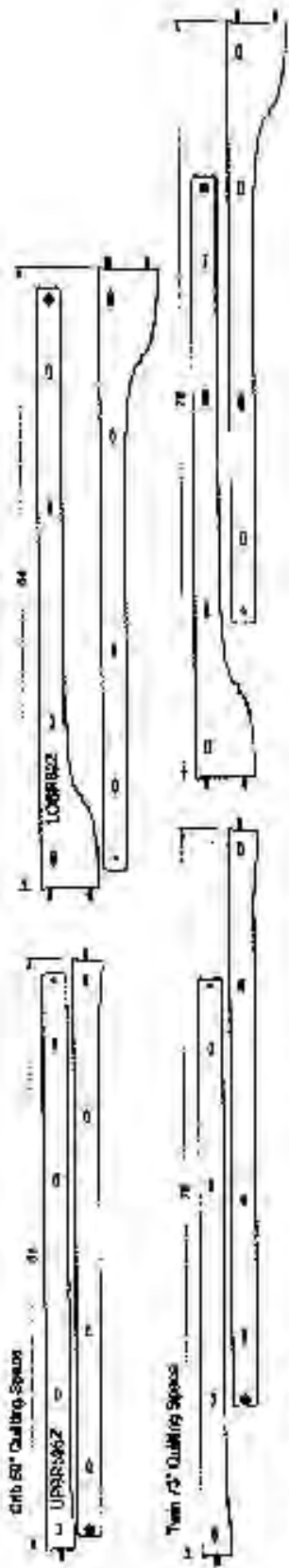

* Optional - Available At Extra Cost

Step 1

Decide which size quilt frame you need to put up. (See sizes in drawing)
Follow the line up of holes as indicated in the pictures according to the size of the frame that you are putting together. Notice the position of the metal insert as shown on the pictures.

- † 5/16" X 1 1/2" bolt
- 5/16" Washer (larger)

T-NUTS ALWAYS SHOW FACING OUT
OF PART AND WILL BE VISIBLE.

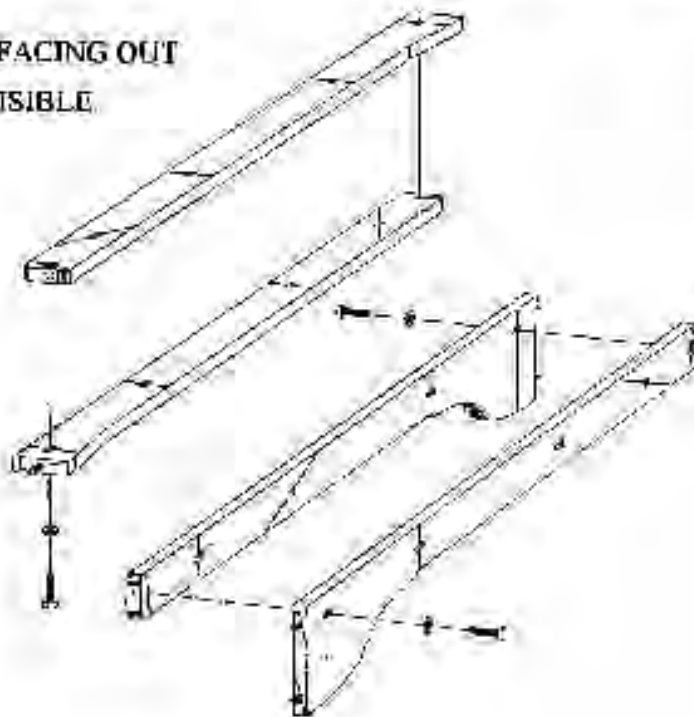

Step 2

Put the large washer on the 5/16" X 1 1/2" bolt and start through the slot first, and continuing through the round hole and into the metal insert T-nut.

Step 3

By hand, begin to tighten all bolts into the threads of the metal insert. Do not tighten the bolts with a socket wrench at this point. Leave them loosely holding the parts together. We will finish tightening them in a following section.

*TIP- Notice the difference in the upper braces and the lower brace sets. *

*TIP- Make sure the metal inserts called T-Nuts still show after assembly of the two braces together.

Section 6. Brace to Stand Assembly

- Parts needed:
- 2 each already assembled Base/Stand/Tilt head/End piece
 - 1 each Lower Brace loosely assembled to size desired
 - 1 each Upper Brace loosely assembled to size desired
 - 6 each 5/16" wing nuts (smaller)
 - 6 each 1/4" washers (smaller)

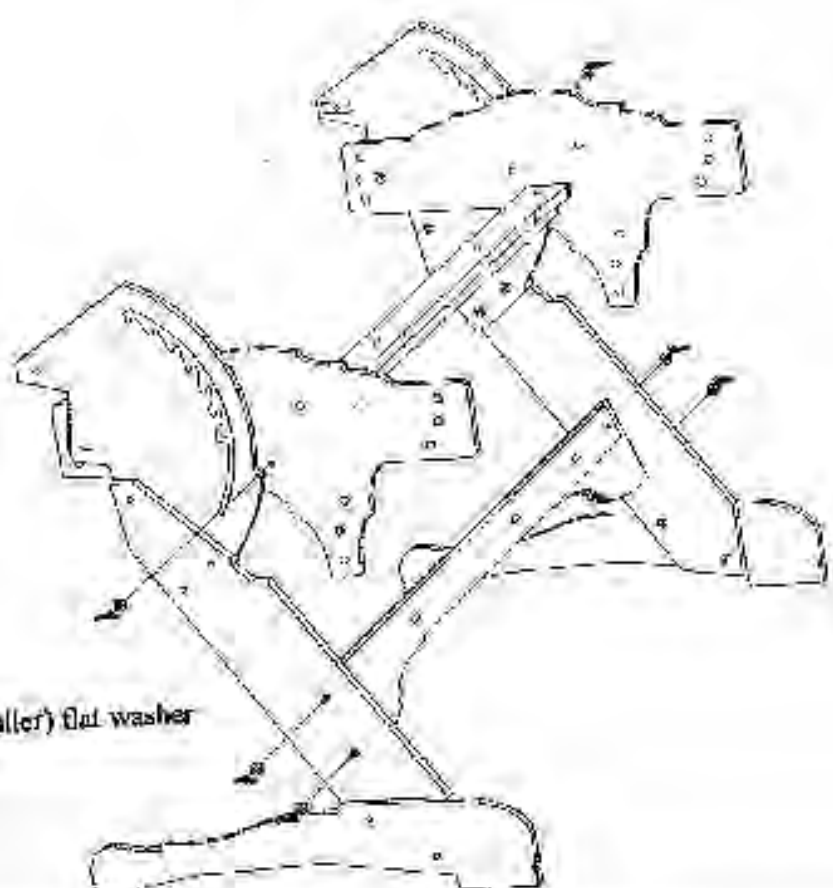

1/4" (smaller) flat washer
5/16" Wing Nut

- Step 1**
Align the hanger bolts that are in the end of the Lower brace into the holes of the left Stand piece. (See picture)
- Step 2**
Place a 5/16" (smaller) flat washer over the end of the Hanger Bolt. Turn the 5/16" Wing Nut onto the ends of the hanger Bolt. Tighten Wing Nuts loosely for now.
- Step 3**
Now align the hanger bolts that are in the other end of the Lower brace into the holes of the Right Stand piece.
- Step 4**
Do same as step 2. Lower brace is on and is expanded with the slots as large as possible to allow for the positioning of the Upper Brace.
- Step 5**
Put Upper Brace in position with slots compressed as much as possible. Insert the hanger bolts of the Upper brace into place. Do this on both ends of the of the Upper brace.
- Step 6**
Place a 5/16" (smaller) washer over the end of the hanger bolt that is through the stand piece and follow with the 5/16" wing nut. Start the wing nuts on both ends by hand catching a few threads on each end just to hold it loosely into place for now.

Step 8.

Adjust the Upper brace to a snug fit in the Stands and tighten up all wing nuts that hold this brace into the Stand part.

***TIP-** All wing-nuts should be firmly tightened now. **DON'T** tighten Hex-head bolts yet!

Section 7. Quilting Pole Assembly

Before beginning assembly of quilting poles, decide which size of the frame you are putting up and use the diagram on the back of this page to select the correct parts in order assemble four pole units. (Quilting Pole Diagram located on page 1).

Parts needed. PL 48-5Z D

PL 19-5Z E

PL 55-5Z F

PL 22-0Z G

1/4" X 1 1/2" Hex-head

1/4" washer (smallest)

7/8" X 2" Plastic washer

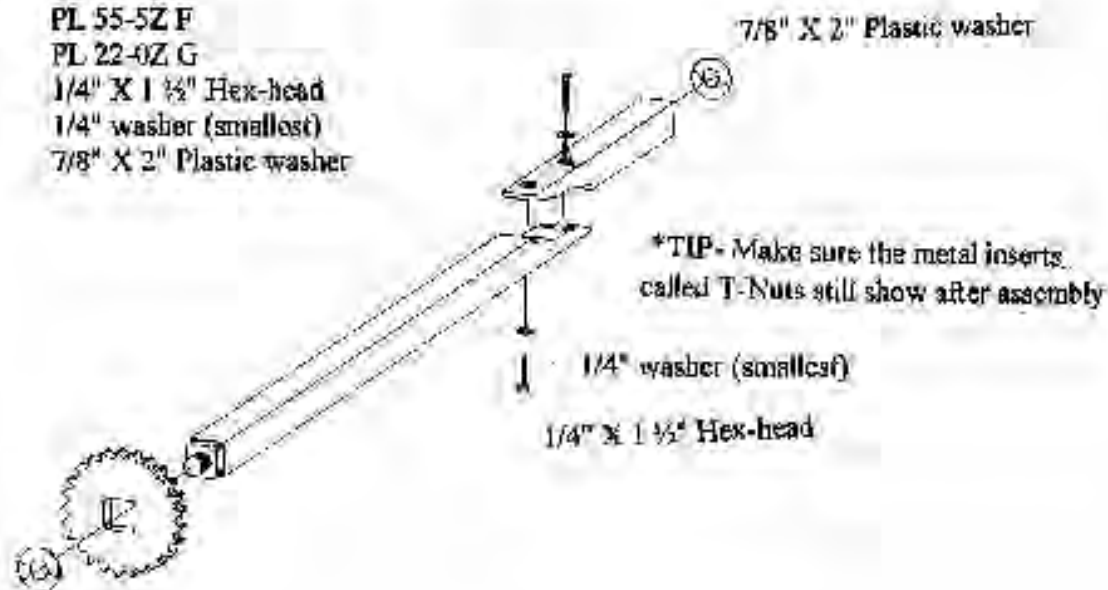

Step 1

Align the slanted ends of the pole parts together and insert each bolt through a small flat washer and into the round hole in the wood. Continue inserting the bolt through to the metal T-nut insert.

Step 2

Begin all the bolts by hand, then tightly holding the wood pole together aligning it squarely on all sides. Line up this joint completely and then use the socket to tighten all bolts.

Step 3

Continue bolting together all slanted ends of poles until you have four quilting poles completed.

Pole Assembly (By Length of Quilting Space)

Quilt must be at least 1" smaller than the overall length of pole.

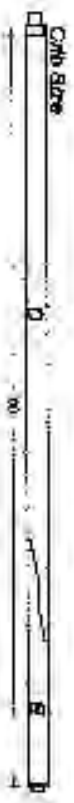

* Optional - Available at Extra Cost

Section 8. Quilting Pole to End Assembly

Parts needed: 4 assembled Quilting poles
8 Plastic washers
3 Cog wheels
3 cog stops
3 each 1 1/2" hex head bolt.

*Tip—Keep these positions of the cog wheel in mind as illustrated below while assembling the Quilting Poles to the Ends.

Cog Wheels are positioned on the right side of the frame.

1/4" x 1 1/2" BOLT SHOULD BE ABOUT 1/4" TOO LONG AND SHOULD NOT BE TIGHTENED WITH ANY TOOL. TIGHTEN THIS PART WITH YOUR FINGERS. TO AVOID DAMAGE



Step 1

Slip the cog wheel onto the quilting pole.
Slip one of the plastic washers onto both ends of the pole.
Stand facing the front of the frame.

Step 2

Position the end of the Quilting Pole that does not have the cog wheel on it into the left front hole in the left end board.

Step 3

Depress the spring loaded pole end on the end of the pole that has the Cog wheel on it. Slip the pole into position and release the spring loaded pole end into the pole hole. Make sure poles are in the same holes on both sides.

*TIP: With the first pole in place, it may be necessary to adjust the width of the frame with the slots in the braces so that the pole will roll freely but will not move more than 1/16" from side to side.

Step 4

Continue placing the next two poles with the cog wheels on them into the holes following the above steps.

Step 5

Install the cog stops with 1/4 x 1 1/2" bolts. **DO NOT OVERTIGHTEN THIS BOLT.** Finger tighten the bolt to a measurement of 1/4" space between the head of the bolt and the wood of the cog stop.

Step 6

Install the remaining pole. This pole does not have a cog wheel on it. This pole to be positioned in the lowest pole hole on the end board. This is the pole for the batting and does not need a cog wheel since the batting should not have tension applied to it.

Section 9, Tuning Up the Z44

Step 1

After all the poles are in place, adjust the Upper Brace so that all the poles will roll freely but will not move from side to side.

Step 2

Tighten the 5/16" hex-head bolts that are in the slots on the Upper Brace.

Step 3

Adjust the Lower Brace so that the tilt action will move smoothly and easily.

Step 4

Tighten the 5/16" hex-head bolts that are in the slots on the Lower Brace.

Section 10, Lamp Holding Bracket to Tilt Head Assembly

Parts needed: 2 each lamp base attachment

1 right Tilt head

1 left tilt head

2 each 1/4" washer

2 each wing nut



Step 1 (see picture)

Insert hanger bolt through hole located on right Tilt head. The lamp base will be positioned on the inside of the right Tilt Head.

Using washer and wing nut, tighten the lamp base into position on the Tilt head.

Assembly of Accessories

Super King Extension assembly

The parts and assembly configuration pictures for the Super King Extension Pole is located on page 12. The Brace parts and assembly configuration pictures for the Super King Extension set up is located on page 7.

Follow these pictures and directions as you set up the frame into the Super King length.

Extra-Long Pole assembly

The parts and assembly configuration pictures for the set up of the Extra-Long Pole is included on the pole and brace pages. Follow the directions for setting up the frame into the Extra-Long Pole length on both the Brace and Pole instructions and pictures.

Edgemaster application

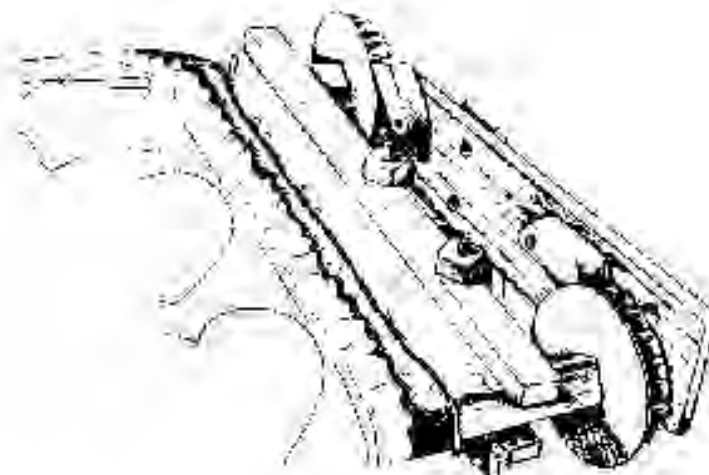
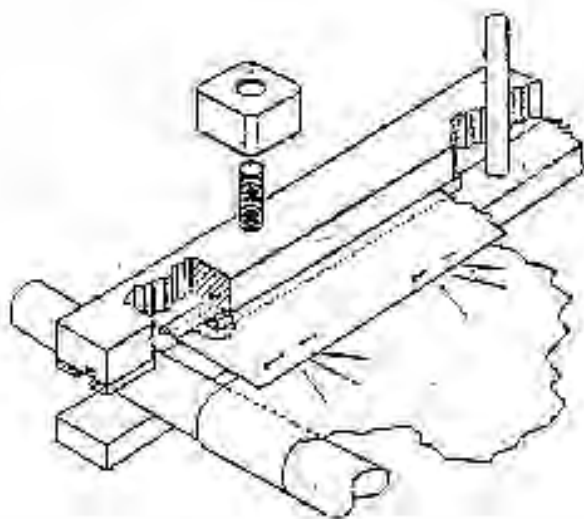

Edgemaster keeps the side tension of the quilting fabric even. Loosen wooden nuts to their maximum open position. Separate the two boards of the Edgemaster and position them with the quilting frame poles or hoop sides between the two Edgemaster boards. Pin quilt edge to muslin strip. Tighten the wooden nut down as you pull gently on the Edgemaster to achieve desired side tension. Do not distort fabric by pulling it too tautly.

Folding The Z44

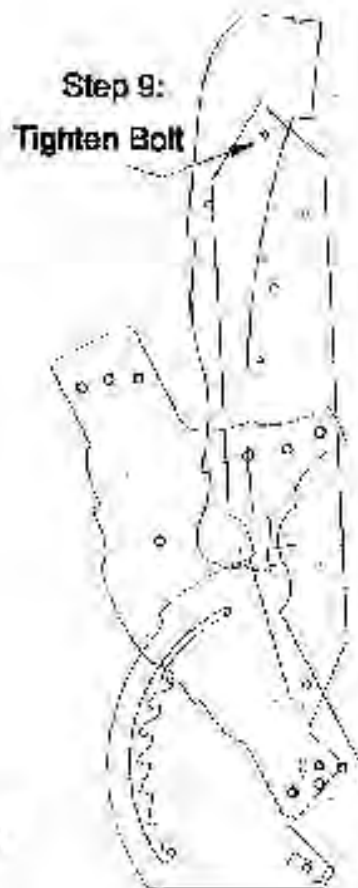
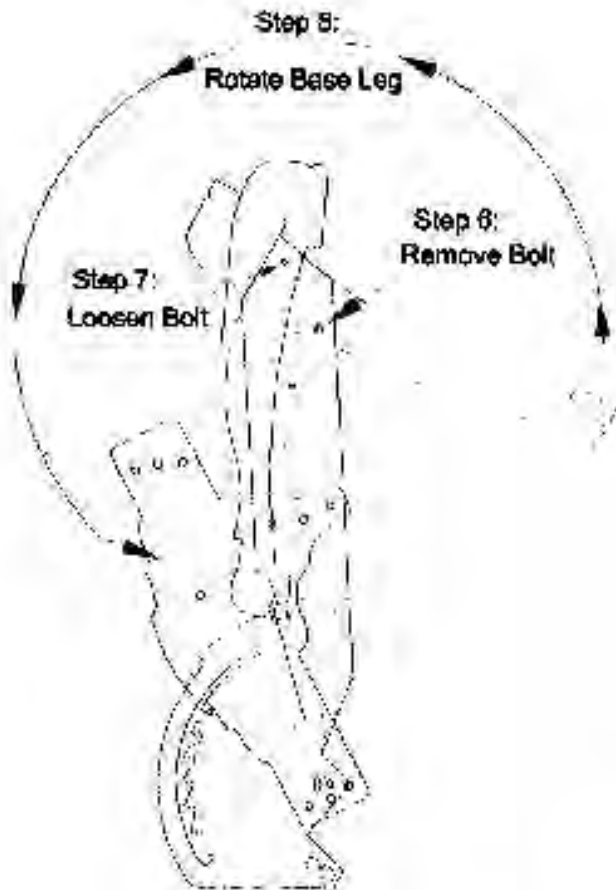
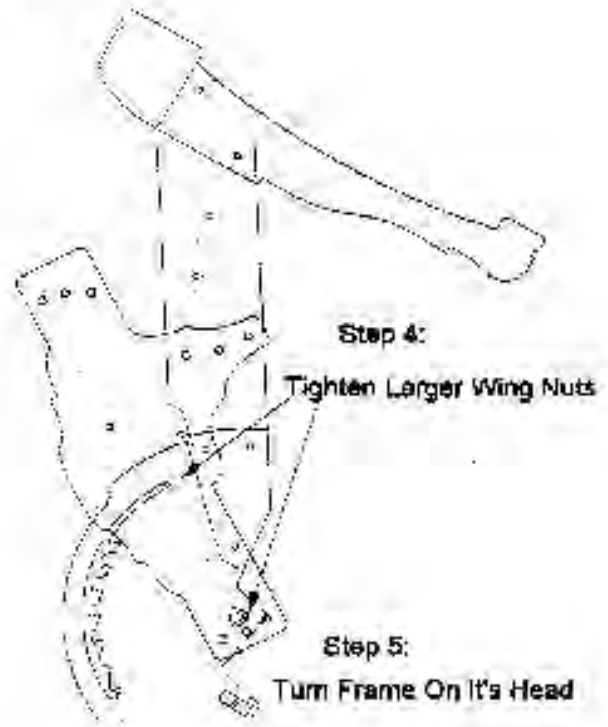
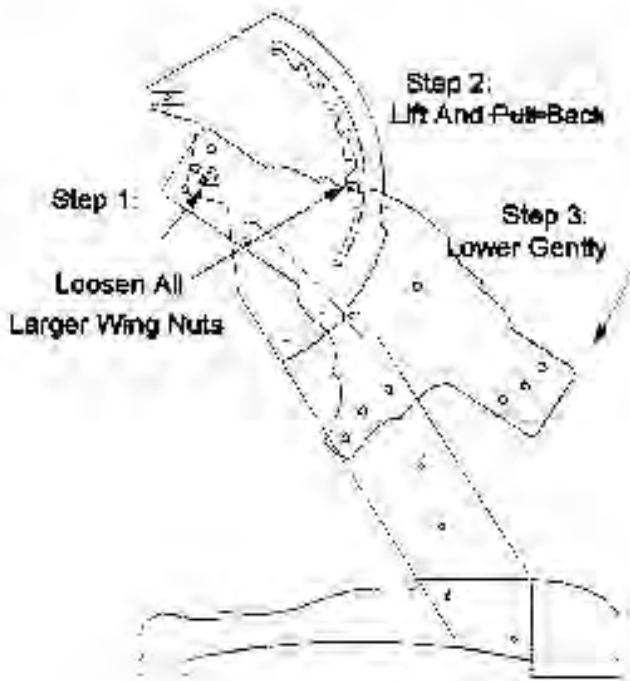

Tilting The Z44

Be sure to stand behind the frame and tilt the whole unit at the same time for crib and twin size assemblies. For queen and larger setups, tilt the frame in smaller steps, one side at a time.

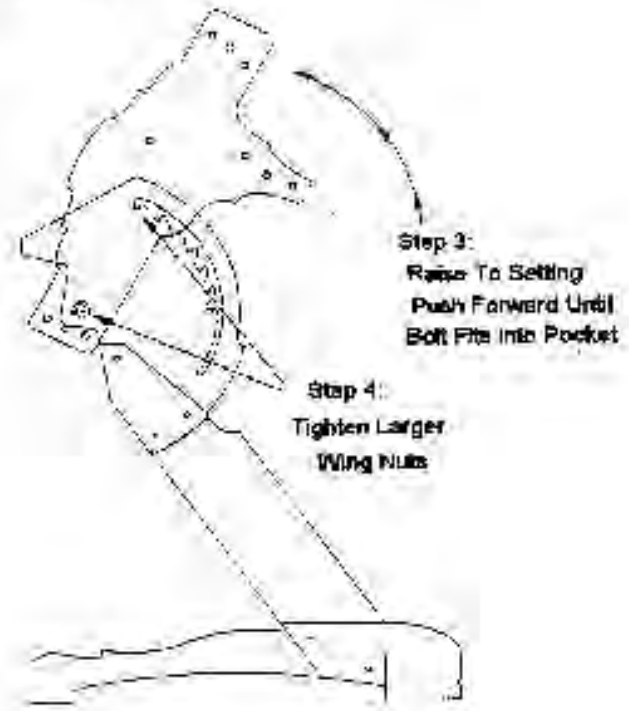
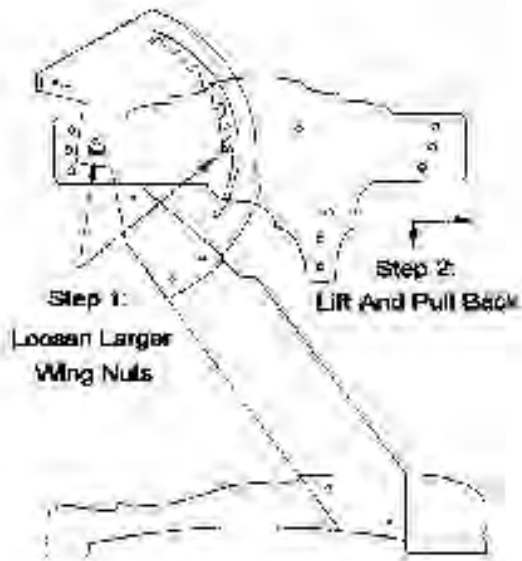

Use of Cloth Leaders

This is a suggestion for making one kind of cloth leaders. There are many ways and ideas for making these leaders. Don't be worried about trying your own idea. Just remember that the longest strip of fabric should be applied to the rear pole. This allows the whole quilt to come up into the area of quilting without stopping and adjusting the quilt top to the second pole in order to finish it.

The best cloth selection for making cloth leaders is unbleached muslin or mattress ticking. However, the ticking is a much more expensive selection.

- Purchase:
- 1 1/2 yards for 58" pole (crib)
 - 2 yards 72" pole (twin)
 - 2 2/3 yards for 94" pole (queen)
 - 3 yards for 108" pole (king)

Step 1

Cut the fabric as illustrated:

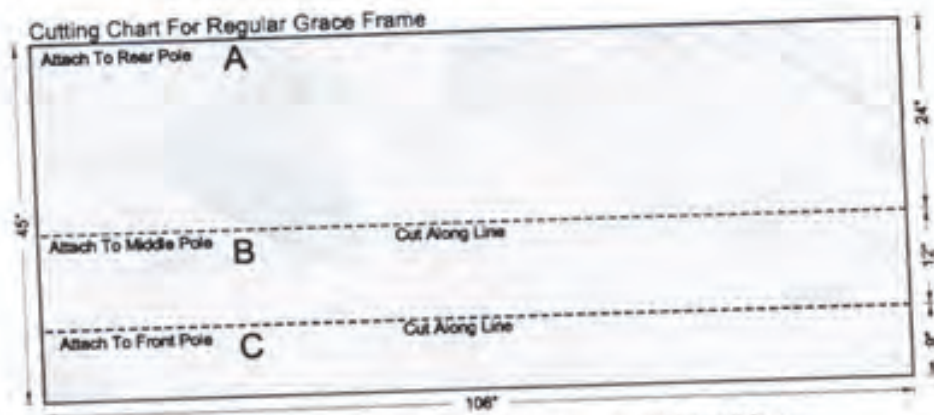
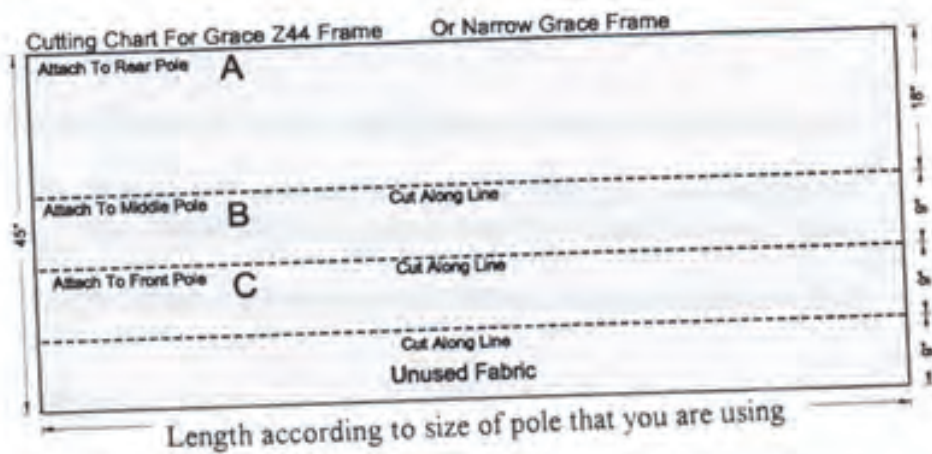

Step 2

Finish the cut edges of the leaders with either a serge stitch or with a very straight 1/2" hem allowance.

Press the leader cloth with a warm iron.

Draw a straight, dark, solid line 1" from one edge of each of the leader cloths.

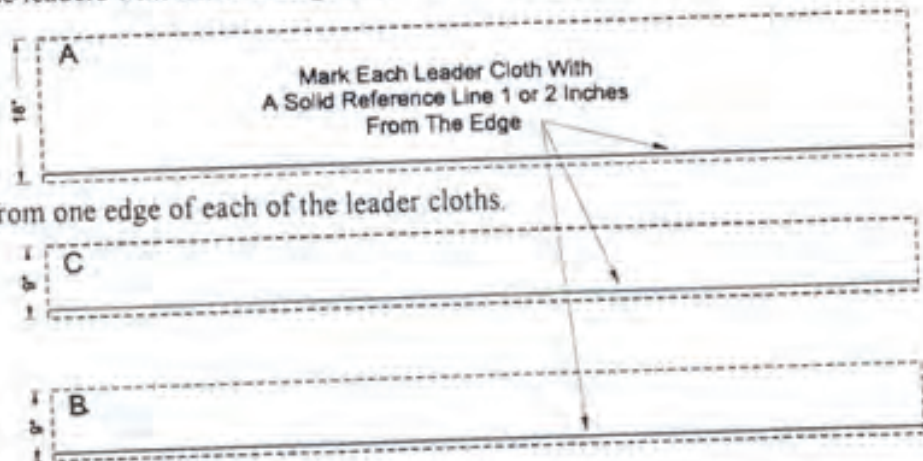

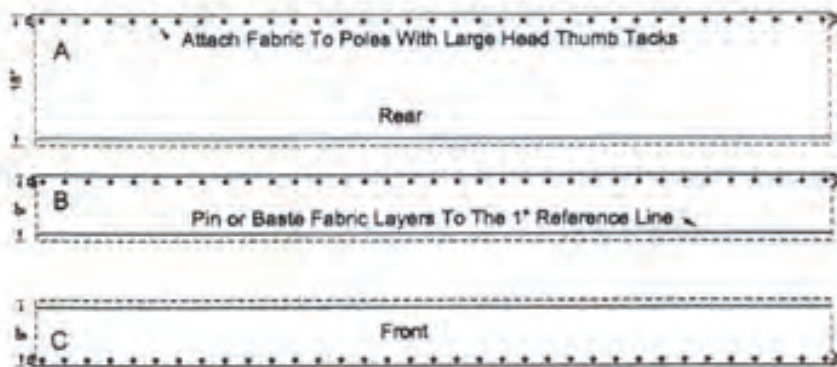

Step 3

Thumb tack the cloth leaders to the poles as shown on above illustration.

Step 4.

Pin or baste your quilt fabrics to the cloth leaders. Use the dark, straight line that you marked on your leaders in Step 2 to align your quilt fabrics with.

Step 5

Roll the cloth leaders and quilt fabrics up as shown in the following illustration.

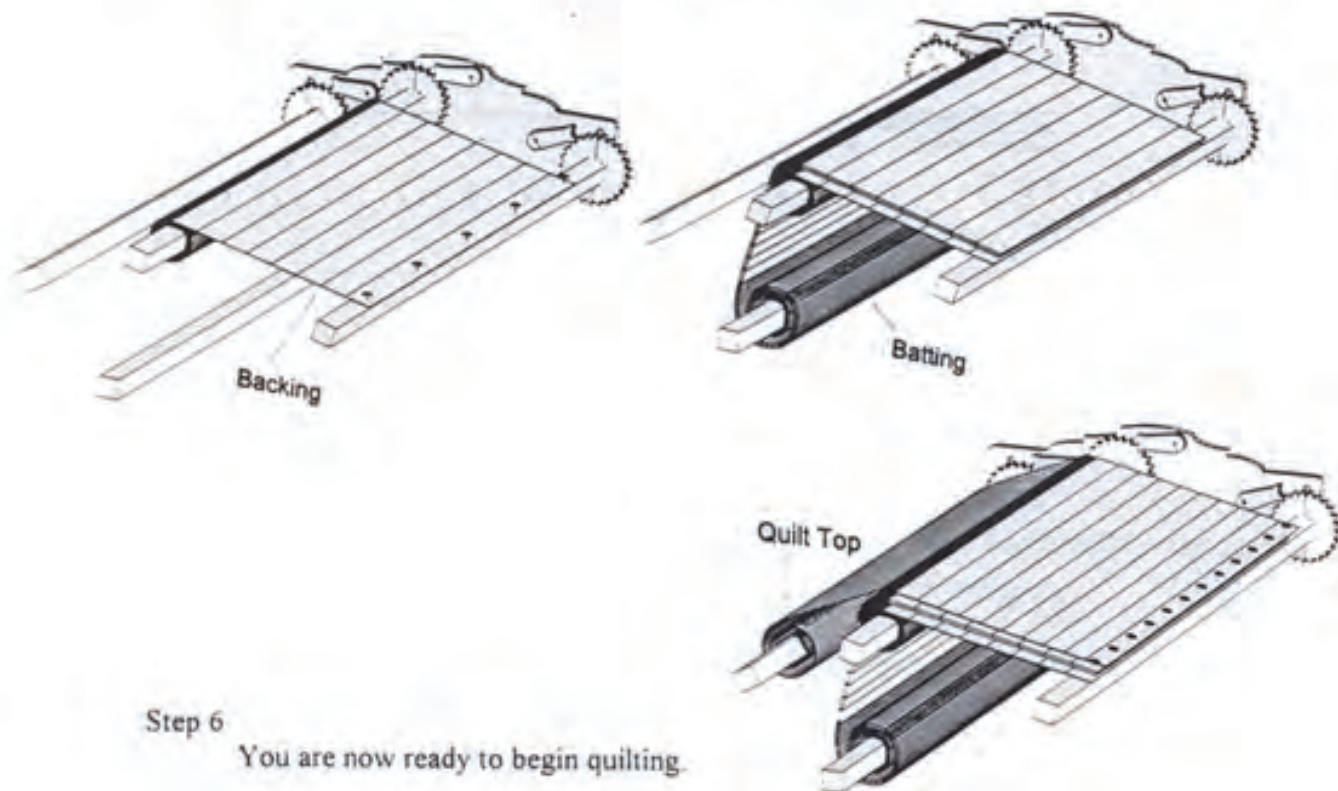

Step 6

You are now ready to begin quilting.

HOW TO USE YOUR GRACE FRAME

Your quilt fabrics may be tacked directly to the poles. However, using cloth leaders is a much better way to attach your quilt (see the cloth leader instruction sheet). Leaders are easy to make and allow the quilter to move the last few inches of the quilt forward from the rear pole to the front quilting area. If you choose to use leaders, refer to those instructions for making them and put them on the frame before applying the quilt fabric to the poles.

1. BACKING FABRIC

The first fabric that will be applied to the quilting frame is the **Backing**.

The **Backing** is also known as the lining fabric. This piece of fabric will be the under side of the finished quilt. It is recommended that this piece of fabric be 2" to 4" larger than the top on all four sides, especially if your top is a pieced top. (A pieced top may possibly stretch out and become larger than the backing if you do not make this allowance). The **Backing fabric** can be one continuous piece of fabric or can be made by sewing fabric together.

Piecing the Backing fabric:

Cut the selvages before you piece the back fabric together. The selvedge is woven more tightly than the rest of the fabric and won't have the same "give" as the rest of the fabric which can cause the seam to be too tight. Use a slightly larger machine stitch than used in normal sewing when piecing the lengths of the back fabric together. Many quilts have **back fabrics** that are not one continuous piece of fabric and are pieced together using two fabric pieces with a seam down the middle or three fabric pieces with two seams having been sewn. You also can sew your back fabrics together using crosswise piecing.

Front pole- **Backing fabric**

1. Mark the center of **Backing fabric** with a pin or a pencil mark.
2. Tack the center mark to the center of the front pole. (The **Backing fabric** is put on with the wrong side of the fabric up and visible.)
3. Lay the fabric naturally and evenly along the straight edge of the pole. Do not stretch the fabric. Tack the corners of the fabric to the pole.
4. Add a few more tacks to hold the material on the pole.

Middle pole- **Backing fabric**

1. Tack the other end of the **backing fabric** to the middle quilting pole, centering with the mark as directed on the front pole.
2. Tack the center mark to the center of the middle pole.
3. Lay the fabric naturally and evenly along the straight edge of the middle pole. Do not stretch the fabric. Tack the corners of the fabric to the pole.
4. Measure the amount of wood showing at the edges of the fabric to the end boards. This measurement should equal the amount showing on the front pole.
5. Securely tack the **Backing fabric** along the entire edge of the middle pole, using plenty of tacks.

Rolling the **Backing fabric** onto the middle pole

1. Roll the material onto the middle pole, making a smooth roll. Be sure there are no wrinkles present.
2. Smooth the quilt from the center to the outside edges of the pole as it is being rolled. At this point do not roll the fabric tightly, just roll it nicely smooth and even.

3. Roll until there is very little slack between the two poles.

Now, from the front of the frame, look at the fabric and readjust the fabric on the front pole if necessary. Sometimes, due to an uneven grain line of the fabric, the fabric will be loose in one area and tighter in another. First, try rolling the fabric completely from the middle pole to the front pole and then back to the middle pole again. Then if this did not adjust the fabric, simply even the tension by adjusting the tacks on the front pole. After adjusting the tension add additional tacks to hold the fabric on the front pole.

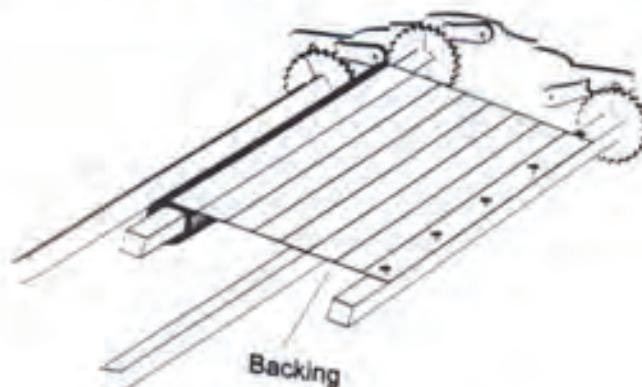

1. Batting

There are two ways to apply the **Batting**. If you have the Z34, follow instruction A or B. If you have the Z44, follow instruction C.

- A. **Batting** is rolled up with the quilt top onto the rear pole. (For bonded batting)
- B. **Batting** is draped between the second and third poles for delicate and extra thick batting.
- C. **Batting** is rolled up on the 4th pole which is the batting pole. The use of the 4th pole makes the quilting process nicer and more efficient. The 4th pole accommodates any kind of batting.

Batting installation #A

1. Place the **batting** edge directly on top of the backing fabric on the front pole, centering the **Batting**.
2. Place the front edge of the quilt top over the **batting** on the front pole remembering to center it correctly.
3. Tack the center of the **batting and quilt top** to the front pole directly lining up these two fabrics over the backing fabric which was previously applied to the front pole. Completely tack the batting and quilt top moving from the center out to each corner. Remember to smoothly and evenly lay the quilt top to the front pole without stretching from corner to corner during the tacking process.
4. Drape the **batting and Quilt Top** over the middle pole.
5. Center the edge of both **batting and top** to the rear pole. Tack the centers of these fabrics to the rear pole and smoothly and evenly tack from center to corners.
6. Measure the wood from quilt edge to end board. This measurement should be equal to the quilt top edge to end board measurement on the front pole.
7. Roll the **batting and quilt top** up on the rear pole.

8. Roll until the materials are smoothly and tautly stretched between the poles. Do not adjust material while rolling- except to adjust any fabric from forming into big creases.
9. Adjust the tension to the **Backing** fabric and **Batting** and **Quilt Top** fabrics until you get the desired tensions. **DO NOT OVER TIGHTEN!** Apply the wood stop to the cog wheels.

Batting installation #B

1. Center the front edge of the Batting on the front pole directly on top of the Backing.
2. Tack the Batting down with a few tacks.
3. Smooth the batting over the Backing and let it drape over the middle pole and onto the floor.

As you quilt and roll, smooth the batting from underneath at the middle pole with each roll.

Batting installation #C: The 4th Pole

1. Center the Batting on the front pole over the Backing and tack down with a few tacks. Smooth batting over the back to the middle pole and let the batting drape to the floor between the middle pole and the 4th pole.
2. Wrap the edge of the batting around the 4th pole-you won't need to tack the batting to the pole.
3. Roll the batting up on the 4th pole making a smooth and tension free roll.

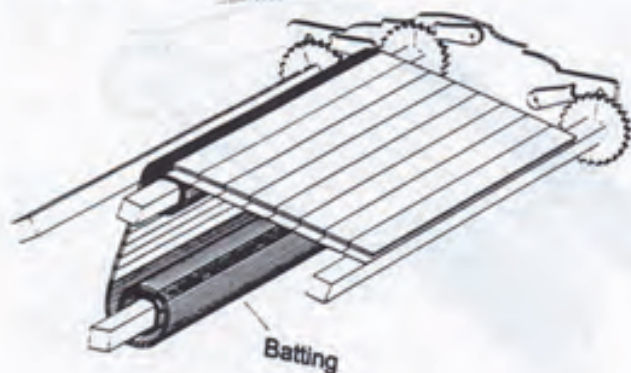

Quilt Top

If you followed Batting installation #A, you would have already applied the quilt top to the frame and are ready to begin quilting.

If you followed #B or #C, continue following these instructions to complete the installation of your Quilt Top.

1. Tack the center of the quilt top onto the center of the front pole.
2. Smooth out the Quilt top from the center to each corner. **DO NOT STRETCH**.
3. Tack the Quilt top along the straight edge of the pole over the Backing and the Batting layers.
4. Drape the Quilt top over the middle pole and let it hang between the middle and rear poles.
5. Tack the center of the Quilt top edge to the rear pole.
6. Smoothly and evenly, without stretching, tack the fabric to the rear pole moving from the center to each corner.
7. Measure the Quilt top edge to the end boards. This measurement should be the same distances as on the front pole.
8. Roll the Quilt top onto the rear pole. Keep this roll smooth and loose, without allowing any wrinkles or creases to occur.
9. Now adjust the tensions of Quilt top and Backing fabrics until you get the desired tension. Adjust the tightness of the fabrics by turning the cog wheels by hand.
DO NOT OVER TIGHTEN. Apply the wood stop to the cog wheels.
10. Begin quilting from the front edge and roll as you go.

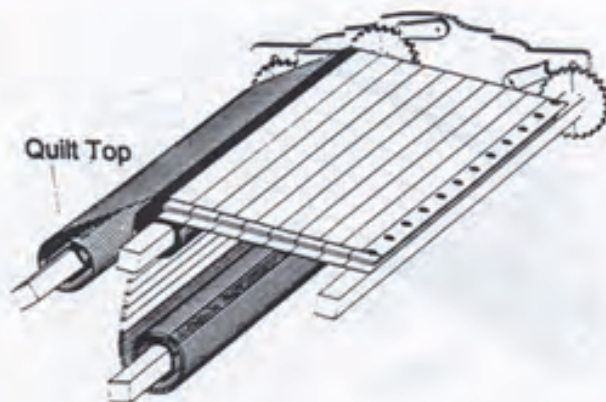

Happy Quilting!

Trouble Shooting

Problem: Fabric sags on one side or in middle

Solution: Fabric may not be cut evenly straight or the grain of the cloth may not be square. Take it off and square it up or pull (gently) to square.

Problem: Sides of quilt have a concave edge

Solution: The fabric was stretched along the pole. Take the fabric off and let it relax until it is not misshapen and then re-install, without stretching it along this edge.

Problem: Quilt backing is much longer than quilt top, after quilting.

Solution: Monitor tension of Backing and Quilt top. Mark on edges of fabrics every six inches on Backing and Quilt top and as you roll you will be able to monitor the tension.

Problem: Batting tears or separates during the tightening of the cogwheels.

Solution: The batting was stretched and stressed. The batting should be longer than the quilt that you are making and there should not be tension applied to it. If you have installed the batting on as described in Batting Installation #A remember to use a few extra inches of batting and let it sag down between the two rear poles. This will stop the batting from pulling. You may unroll the rear pole and fix the batting at any time during the quilting process. If you used Batting installation #B or #C check the 4th pole kit to make sure that it is rolling smoothly and easily.

Problem: Poles are bowing in.

Solution: The causes may be: 1. Seam down the center of the fabrics may be sewn too tightly and is not giving with the rest of the fabric. If the seam is the problem the quilt may be attached sideways. 2. Fabric is not cut evenly. 3. Too much tension has been applied. 4. Fabric has been stretched along the poles instead of smoothly laid along the pole then attached.



Problem: Fabric pulls/tears out at the thumbtacks when tension is applied.

Solution: Seat the tack all the way in. The head of the tack, not the post of the tack, should hold the fabric. Use a tack hammer to seat the tacks if your hand is not strong enough.



Problem: Poles squeak as they roll or they do not roll freely.

Solution: The frame is not square. Square it up with the floor using a carpenters square or an uncut piece of poster board or a picture frame. If the quilting frame still squeaks after making sure that the frame is in good square alignment, rub some paraffin or candle wax on the dowel ends of the poles.

Helps for Tied Quilts:

Before installing the quilt onto the frame, mark both the Quilt Top and Backing in similar increments along the two side edges. (The sides that are not tacked onto the poles) While rolling the quilt during the tying process watch the marks. This will help you to keep an equal tension on the top and backing fabrics so you won't over tighten one or the other of your fabrics.

When rolling into a new area of tying, allow your last row of ties to remain in the new area of tying. Also, tie your knots tight. **Do not over roll past your last row of ties.**

