

# *Q-Zone* *Hoop-Frame*

## **Assembly & Use Instructions**

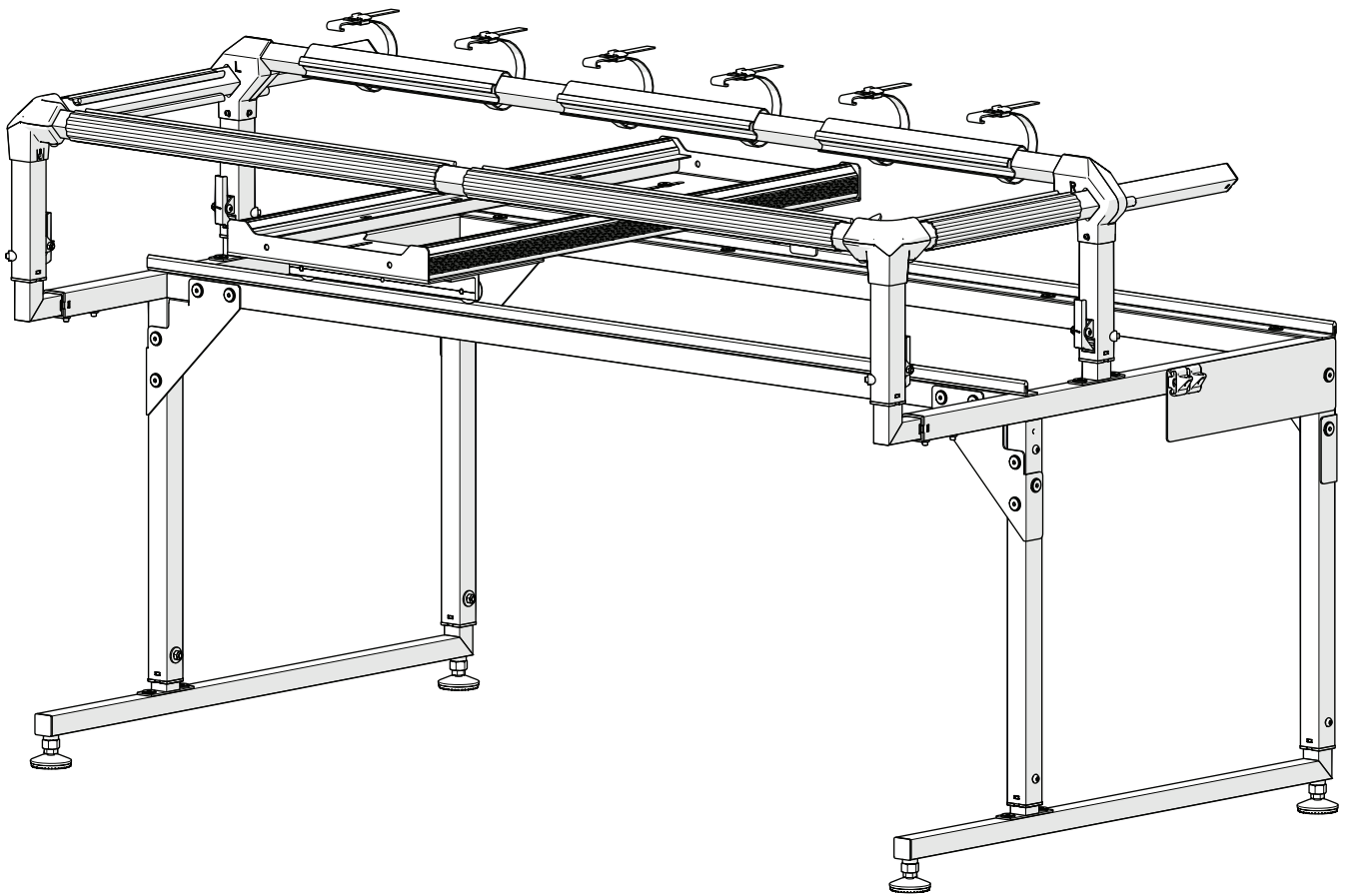

# Contents

My Frame Details .....	ii
Included Parts and Tools.....	iii
Welcome to Your Q-Zone Hoop Frame.....	1
<b>Part One .....</b>	<b>3</b>
Task 1 - Set the Frame Height.....	4
Task 2 - Install the Corner Brackets .....	6
Task 3 - Install the Frame Tracks .....	9
Task 4 - Install the Single-Wheel Channel Lock .....	11
Task 5 - Align the Tracks.....	14
<b>Part Two .....</b>	<b>17</b>
Task 6 - Install the Dual-Wheel Channel Lock.....	18
<b>Part Three.....</b>	<b>21</b>
Task 7 - Install the Rails.....	22
Task 8 - Set Rail Height .....	26
Task 9 - Install the Fabric Bungees .....	30
Task 10 - Level the Frame .....	32
Task 11 - Fabric Clip Placement.....	34
<b>Part Four.....</b>	<b>36</b>
Building Your Quilt Sandwich .....	37
Positioning the Quilt on the Frame .....	39
Using the Bungees .....	42
Tacking Down Your Quilt .....	44
Moving Your Fabric .....	45
Using the Channel Locks .....	47
Quilts of Alternative Size and Shape .....	48
Getting Started .....	51

## My Frame Details

Use this page to write down some information about your frame. This will be helpful if you ever need to call a Grace Company support technician.

Frame Type: Q-Zone Hoop

Date of Purchase: \_\_\_\_\_

What Machine are You Using? \_\_\_\_\_

Select Which Frame Accessories You Have Purchased:

Table Inserts

Speed Control

QuiltMotion

Gracie Laser

Pattern Perfect

Sure Stitch

G-Series Top Plate

Sure Stitch Elite

Power Strip Accessory

Start-Right Cloth Leaders

# Included Parts and Tools

## Box 1

**Left Leg Assembly**

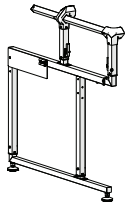

QZF-09-13037  
See page 4

**Right Leg Assembly**

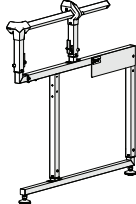

QZF-09-13038  
See page 4

**Side Fabric Clip (x2)**

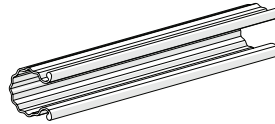

QZH-05-12024  
See page 34

**Corner Bracket A-Side (x2)**

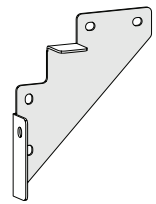

QZH-04-16331  
See page 6

**Corner Bracket B-Side (x2)**

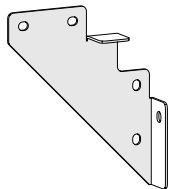

QZH-04-16332  
See page 6

**Bungee Mount (x4)**



QZH-05-12054  
See page 30

**Bungee Clamps (4 pack)**



ACC-01-10261  
See page 30

**Connector Bolt M6 x 10 mm (x20)**

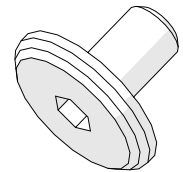

HDW-03-10953  
See page 6, page 9

**Open-End Wrench  
10 mm & 13 mm**

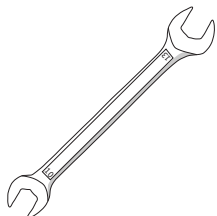

HDW-03-10743  
See page 4, page 32

**Open-End Wrench  
14 mm & 17 mm**

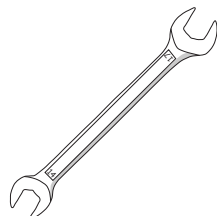

HDW-03-12068  
See page 32

**Allen Wrench  
3 mm**

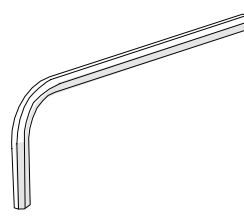

HDW-03-10166

**Allen Wrench  
4 mm**

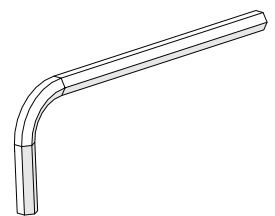

HDW-03-10167



## Box 2

**Back  
Long Rail**



QZF-09-13040  
See page 22

**Hoop Front  
Rail**

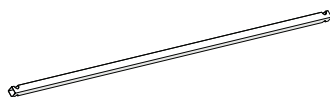

QZH-04-12030  
See page 22

**Table Support  
Assembly (x2)**

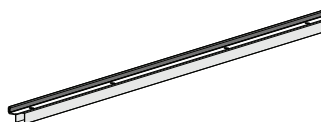

QZF-09-13055  
See page 9

**Front  
Fabric Clip (x2)**

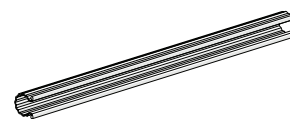

QZH-05-12025  
See page 34

**Back Rail Fabric  
Clip (x3)**

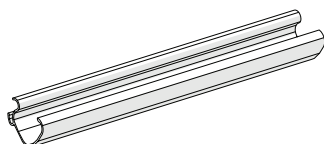

QZH-05-12023  
See page 34

## Box 3

**Bottom  
Carriage**

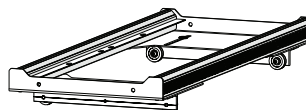

ACC-01-11950  
See page 11

**Single-Wheel  
Channel Lock**

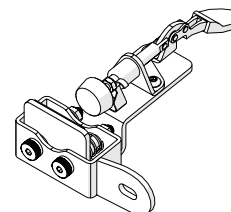

ACC-09-13056  
See page 11

**Dual-Wheel  
Channel Lock**

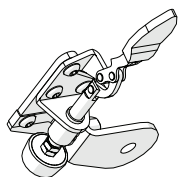

ACC-09-13057  
See page 18

**Channel Lock  
Washer**

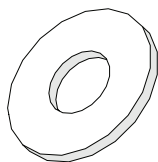

HDW-03-11580  
See page 11

**SBHCS  
M6 x 20 mm**

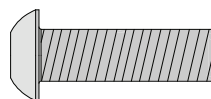

HDW-03-10088  
See page 18

**Frame Reference  
Card Hook**

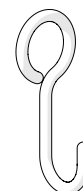

HDW-03-16369  
See page 6

# Welcome to Your Q-Zone Hoop Frame

We are pleased to introduce you to the newest part of your quilting setup. This frame has been especially designed to help quilters like you have the tools available to create quality projects.

This manual is broken into four sections (or parts). Notifications at the end of each section will direct you to switch to your machine manual or QuiltMotion manual for instructions on assembling those products. This creates a streamlined process of building a complete quilting setup in the most efficient way. Use the following flowchart to guide you in navigating multiple manuals. If you are not using one of the products in the flowchart, just move to the next item in the chart.

Thank you again for choosing us to help with your quilting projects. We look forward to working with you.

- The Grace Company

## **Start Here: Frame Manual: Part One**

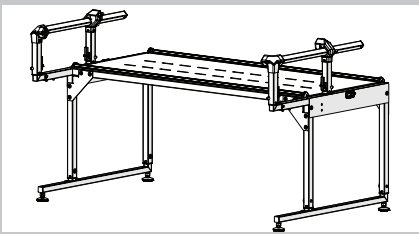

- Assemble the frame's legs, table, and sides.
- Install the channel lock onto the bottom carriage.
- Align your tracks.

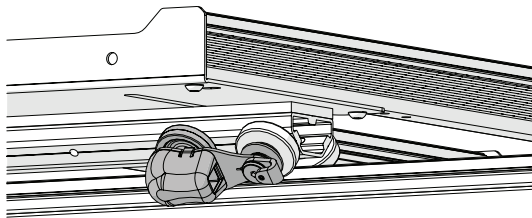

## **Quilting Machine Manual: Part One**

- Install the lower encoder onto the bottom carriage.

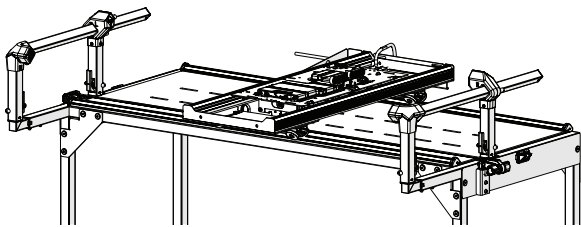

## **QuiltMotion Manual: Part One**

- Prepare the bottom carriage.
- Install the long belt across the frame.

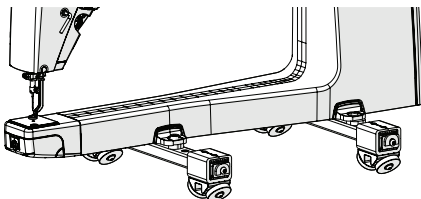

## **Quilting Machine Manual: Part Two**

- Install your machine's wheels.
- Align your wheels.

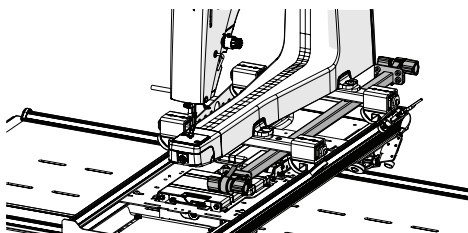

## **QuiltMotion Manual: Part Two**

- Install the short belt.
- Tension the short belt.

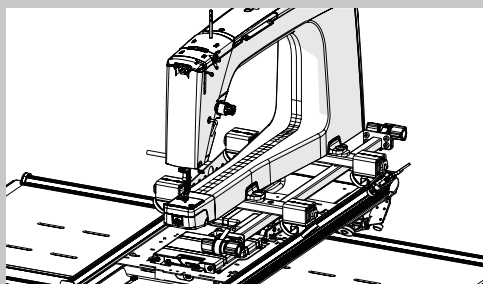

### Frame Manual: Part Two

- Install the channel lock on the machine or top plate.
- Prepare the top plate and home sewing machine.
- Place the machine or top plate on the frame.

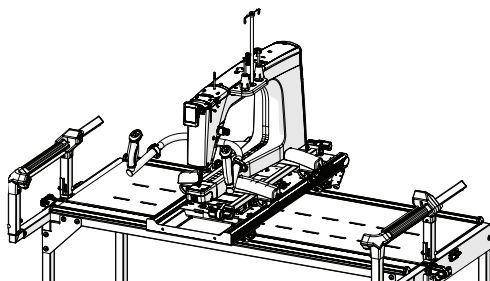

### Quilting Machine Manual: Part Three

- Install the wheel covers, display, handles, thread mast.
- Install the upper encoder.

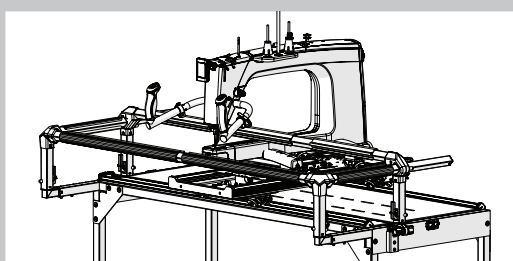

### Frame Manual: Part Three

- Install the rails and fabric bungees.
- Position and adjust the rails.
- Adjust the carriage stop.
- Level the frame.

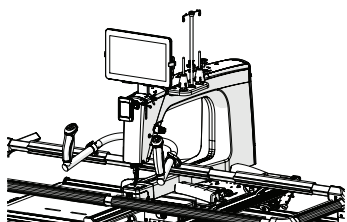

### QuiltMotion Manual: Part Three

- Install the tablet bracket.
- Plug in QuiltMotion.

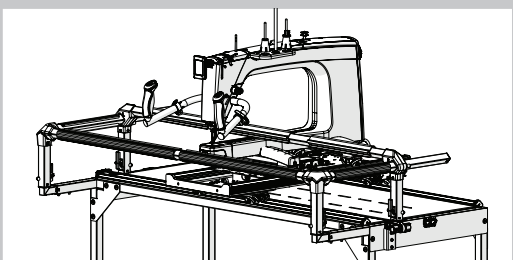

### Frame Manual: Part Four

- Install the velcro tape
- Install the cloth leaders
- Attach the fabric

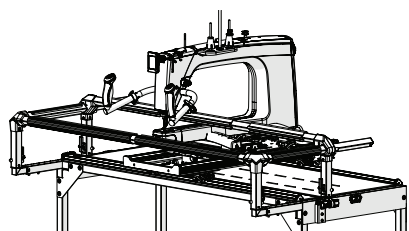

### Quilting Machine Manual: Part Four

- Use the quilting modes and settings in the display.
- Maintain the machine and perform repairs.



# Part One

Complete Part One of these instructions before assembling your quilting machine or any accessories.

At the end of each part, you will be instructed to switch to specific sections of your machine manual, QuiltMotion manual, or other accessories, if you've purchased them and are preparing to assemble them at this time. If you not made those purchases, simply skip those steps.

## Task 1 - Set the Frame Height

### Parts & Tools Needed:

Left Leg Assembly

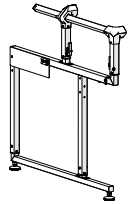

Right Leg Assembly

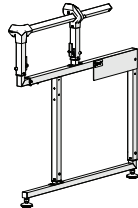

Allen Wrench  
4 mm

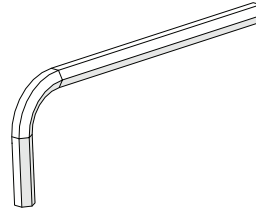

Open End Wrench  
10 mm and 13 mm

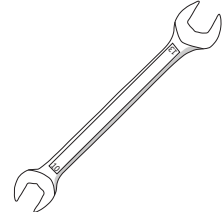

### Instructions

The frame height is important for comfortable prolonged use. Ideally, when fully assembled the handlebars on your machine or top plate will be around elbow height. Take the following steps to set your frame height:

- 1 On Both the Right and Left Leg Assemblies:** With the 4 mm Allen wrench and the 10 mm open-end wrench, remove the **height screws, washers, and nuts**.

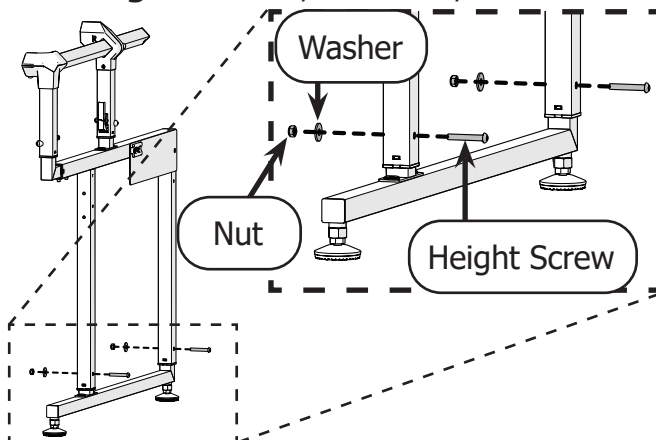

- 2 On Both the Right and Left Leg Assemblies:** Loosen the **connector bolts** near the front leveling foot.

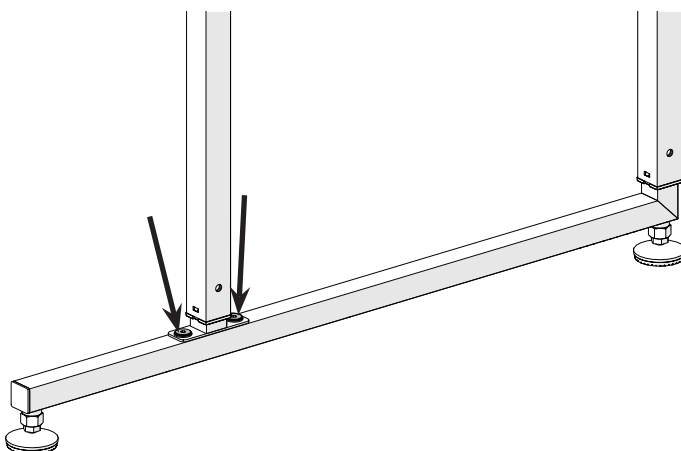

- 3** While standing straight, hold your elbow at a 90 degree angle. Use a tape measure to find the distance between your elbow and the floor.

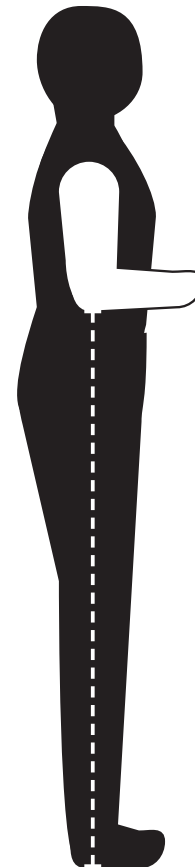

Task 1 - Set the Frame Height (Continued)

4 **On both leg assemblies:** Find the hole number that corresponds with your elbow height in the chart. Then lift the top part of each leg to align its two screw holes with the hole you've chosen in the bottom part of the leg. Make sure both leg assemblies are set to the same height.

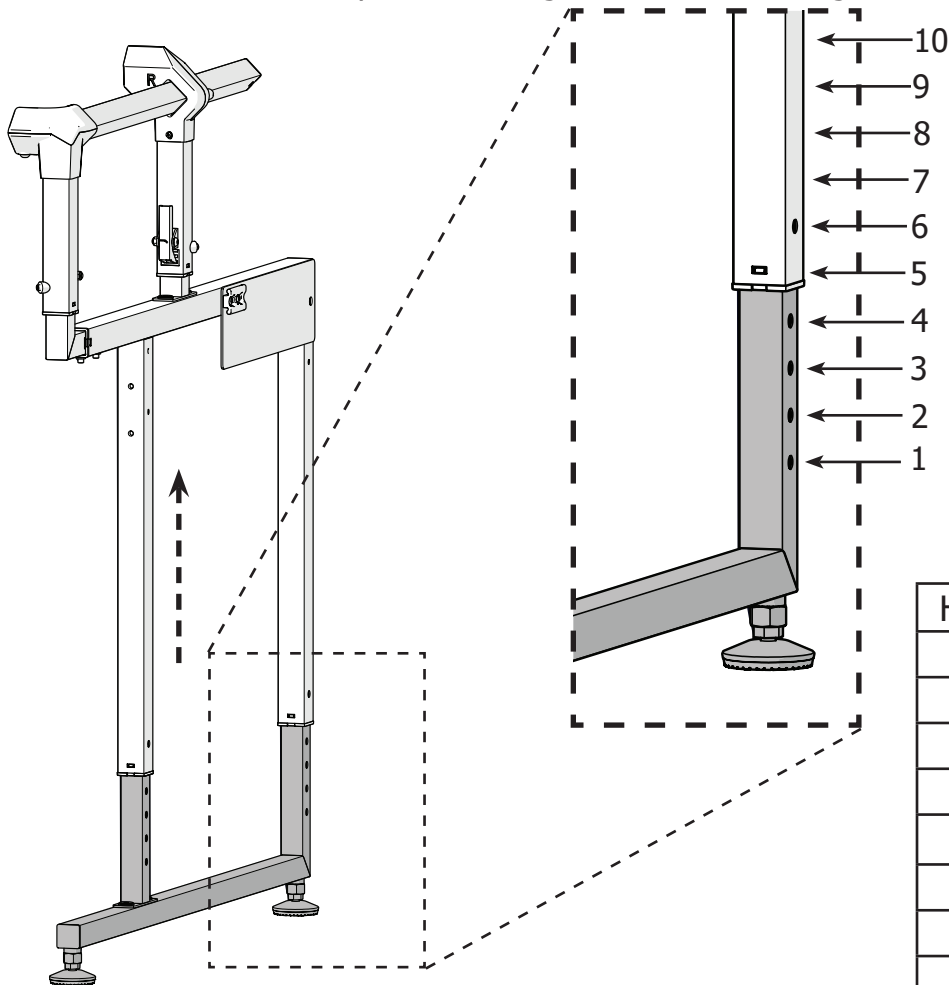

Hole Number	Elbow Height
1	37 Inches
2	38 Inches
3	39 Inches
4	40 Inches
5	41 Inches
6	42 Inches
7	43 Inches
8	44 Inches
9	45 Inches
10	46 Inches

5 **On Both the Right and Left Leg Assemblies:** Re-install the height screws, washers, and nuts. Then re-tighten the connector bolts.

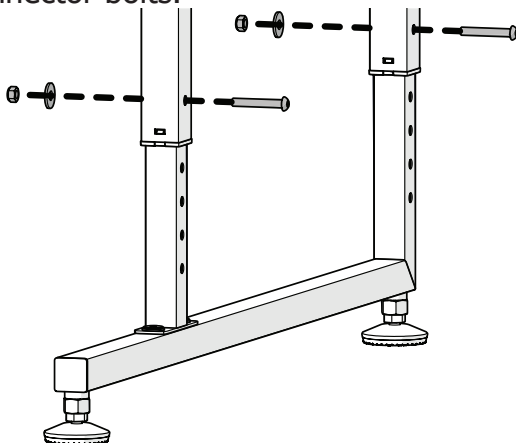

6 Result: Both leg assemblies are set to the ideal height for comfortable quilting.

## Task 2 - Install the Corner Brackets

### Parts & Tools Needed:

Corner  
Bracket A-Side (x2)

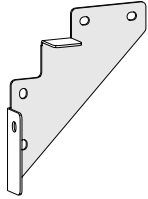

Corner  
Bracket B-Side (x2)

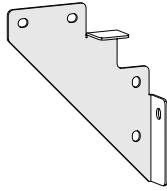

Connector Bolt  
M6 x 10 mm (x12)

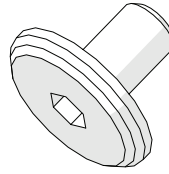

Allen Wrench  
4 mm

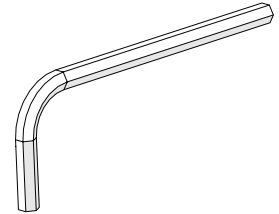

Frame Reference  
Card Hook

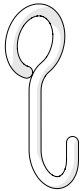

### Instructions

The corner brackets attach the legs to the table part of the frame. Take the following steps to install the corner brackets:

- 1 Loosely install an **A-Side Corner Bracket** onto the front of the **right leg assembly** with two **M6 x 10 mm connector bolts** and a 4 mm Allen wrench. Do not tighten.

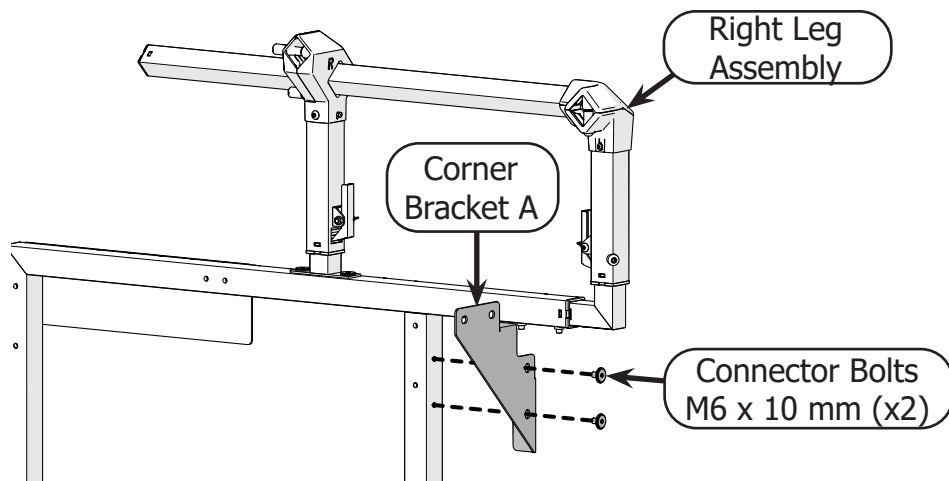

## Task 2 - Install the Corner Brackets (Continued)

- 2 Use a third **M6 x 10 mm connector bolt** to attach the **frame reference card hook** to the front of the **right leg assembly** with the 4 mm Allen wrench. Do not tighten.

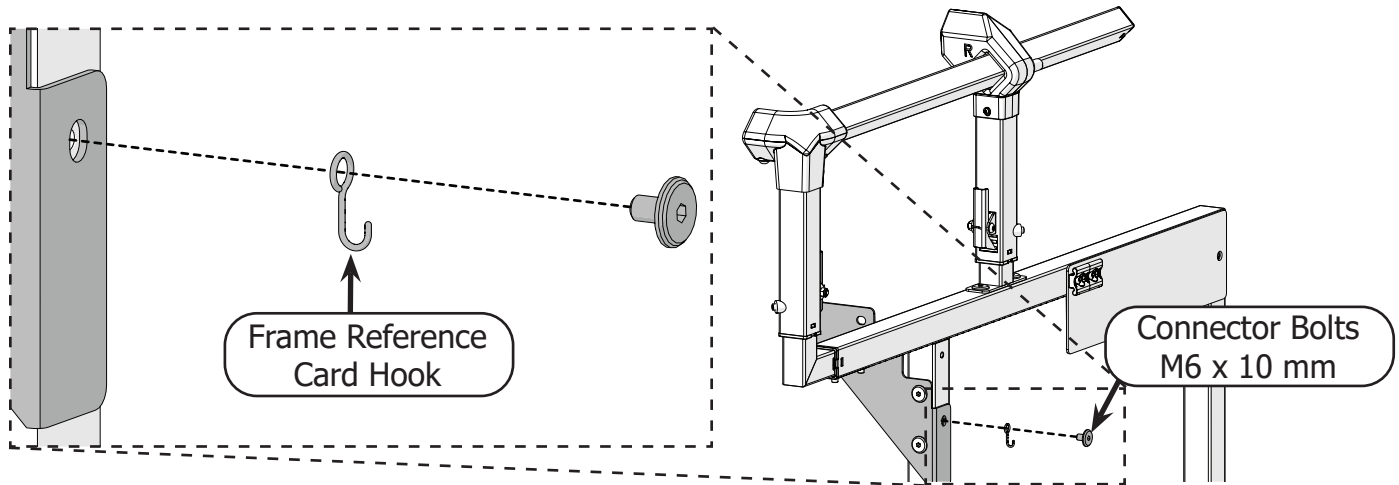

- 3 Loosely install a **B-side corner bracket** onto the back of the **right leg assembly** with three **M6 x 10 mm connector bolts** and a 4 mm Allen wrench. Do not tighten.

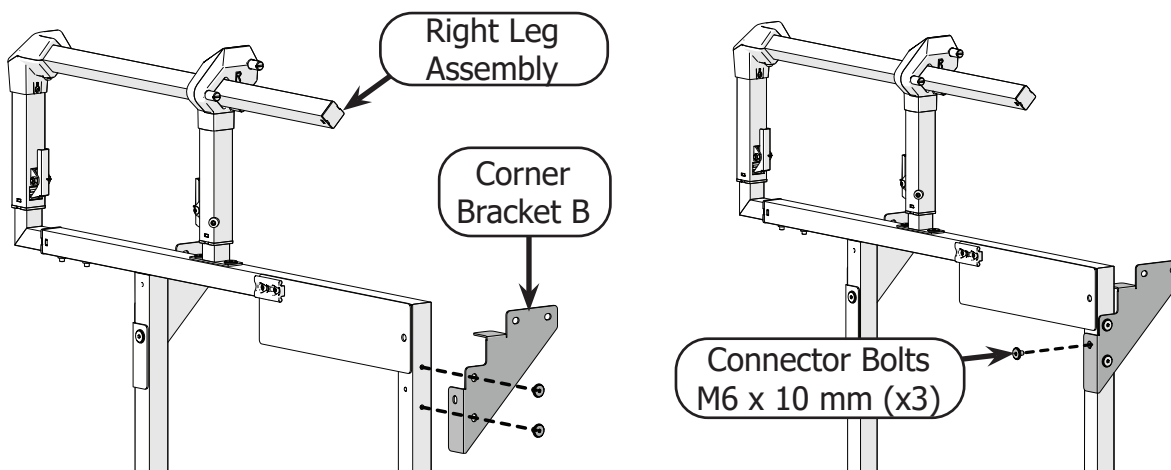

- 4 Loosely install a **B-side corner bracket** onto the front of the **left leg assembly** with three **M6 x 10 mm connector bolts** and a 4 mm Allen wrench. Do not tighten.

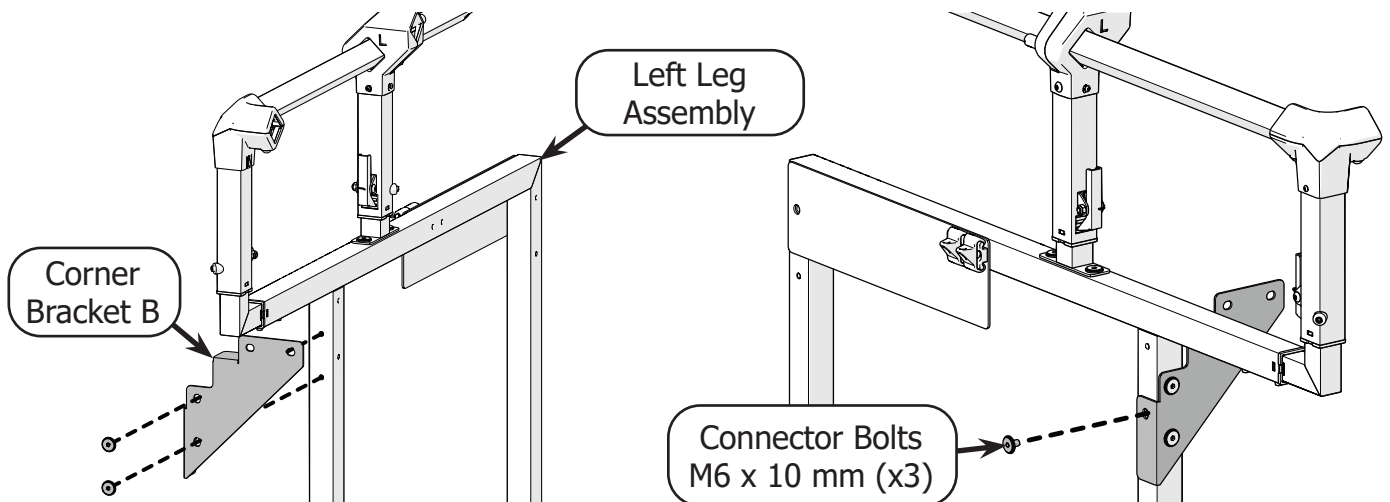



## Task 2 - Install the Corner Brackets (Continued)

- 5 Loosely install an **A-side corner bracket** onto the back of the **left leg assembly** with three **M6 x 10 mm connector bolts** and a 4 mm Allen wrench. Do not tighten.

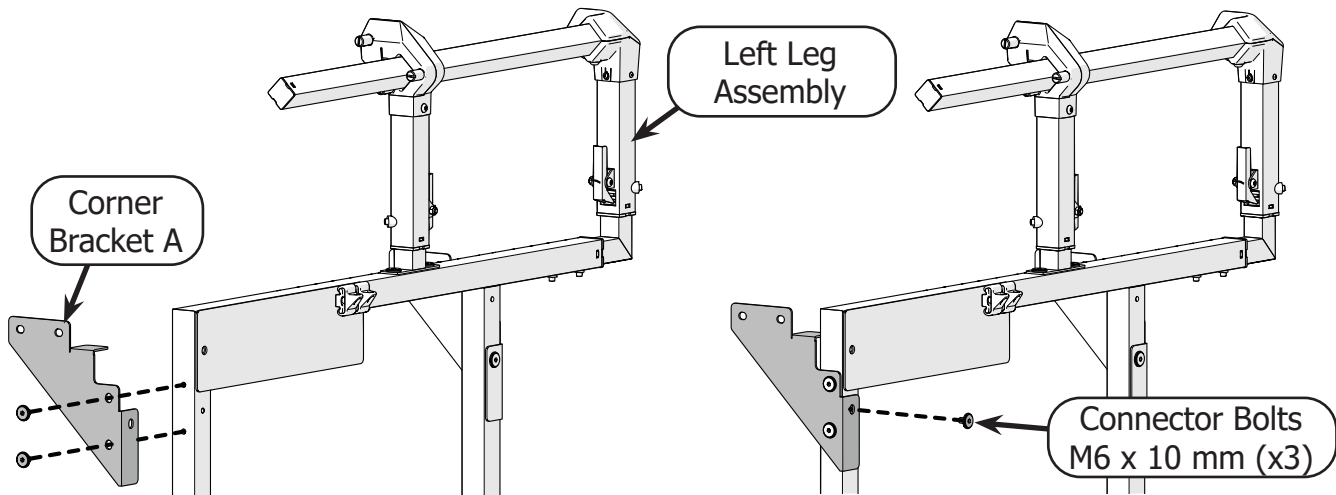

- 6 Result: Corner brackets are loosely installed onto the frame legs.

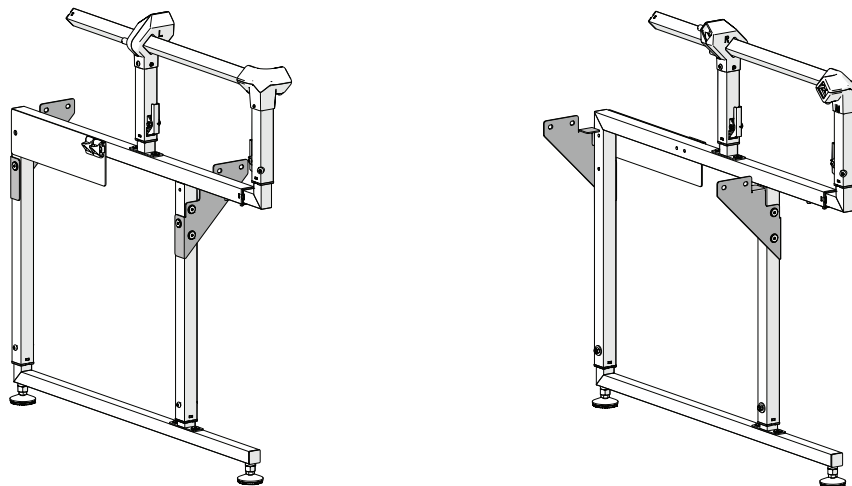

**Tip:** Once you've assembled your frame, you can hang your **reference cards** off the reference card hook.

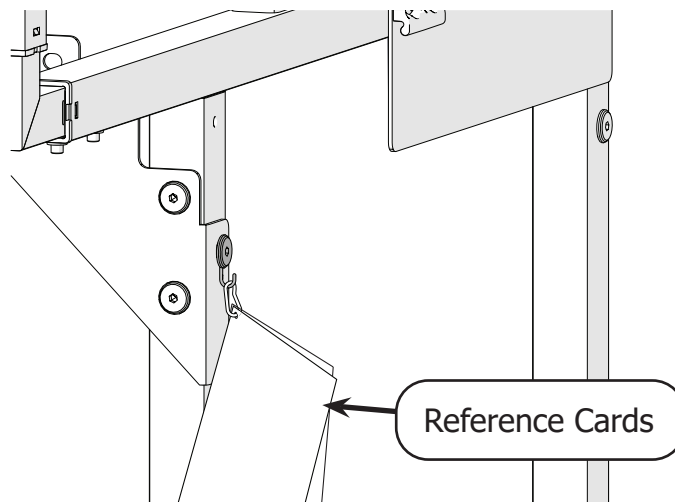

## Task 3 - Install the Frame Tracks

### Parts & Tools Needed:

Table Support  
Assembly (x2)

Connector Bolt  
M6 x 10 mm (x8)

Allen Wrench  
4 mm

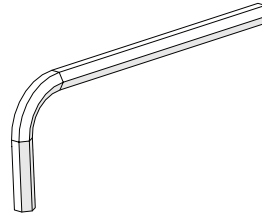
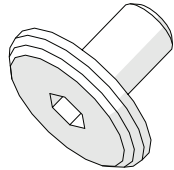
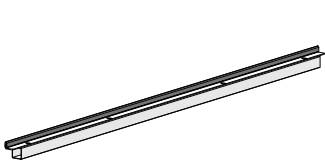

### Instructions

Take the following steps to install the frame tracks (table support assemblies):

- 1 Loosely attach one of the **table support assemblies** to the A-side corner bracket on the right leg with two **M6 x 10 mm connector bolts**. Do not tighten.

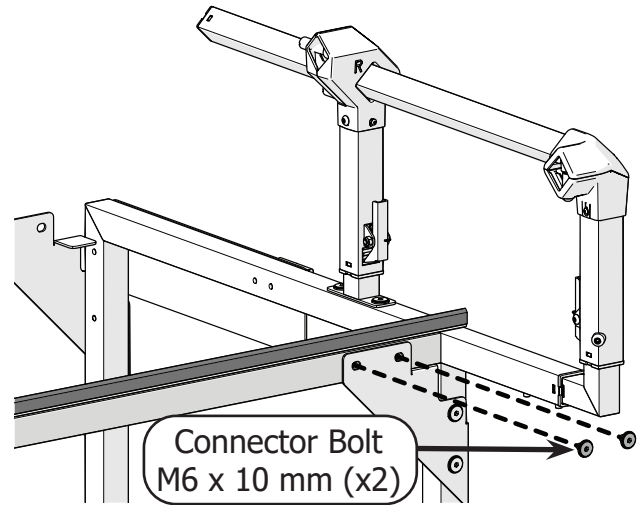
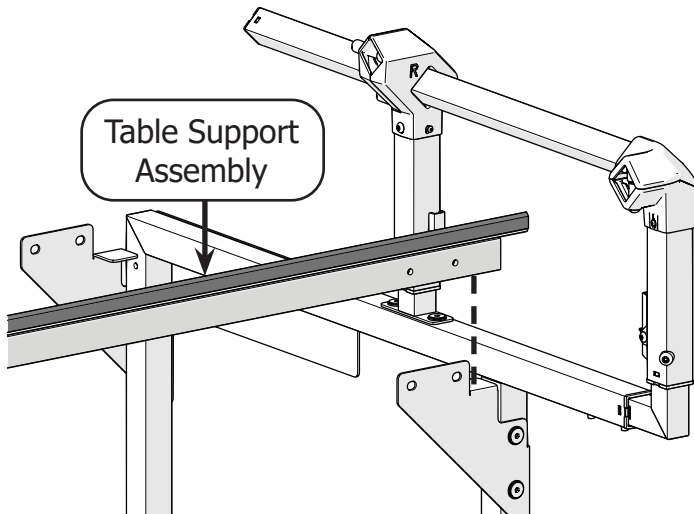

- 2 With two **M6 x 10 mm connector bolts**, loosely attach the other side of the table support assembly to the corner bracket B on the left leg. Do not tighten.

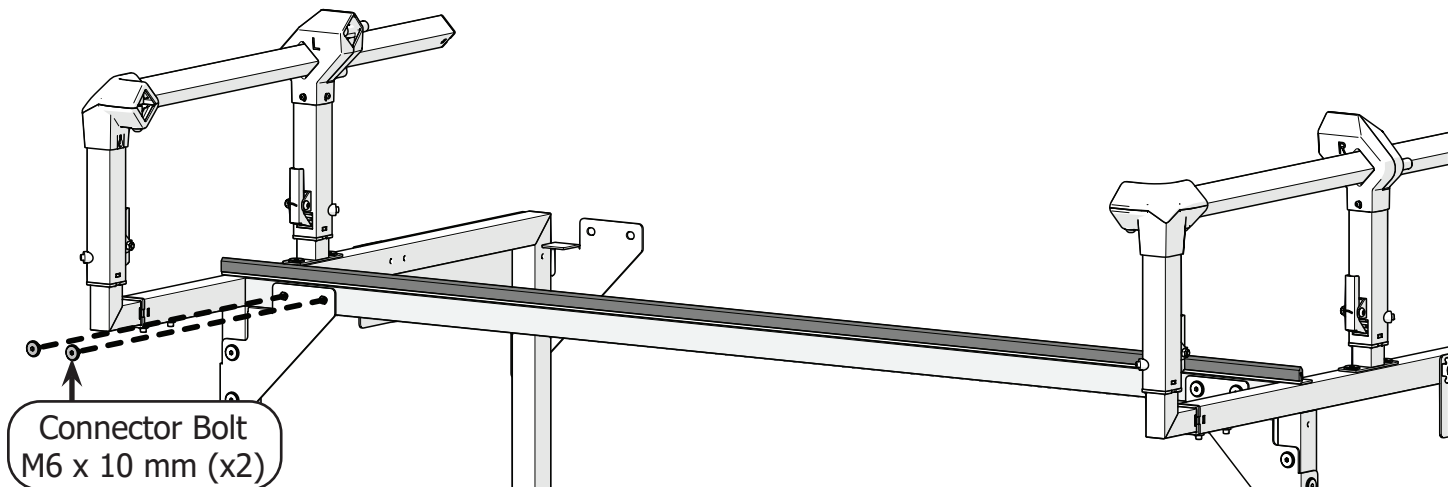

## Task 3 - Install the Frame Tracks (Continued)

- 3 Loosely attach the remaining **table support assembly** onto the corner brackets at the back of the frame. Use four **M6 x 10 mm connector bolts** and the 4 mm Allen wrench. Do not tighten.

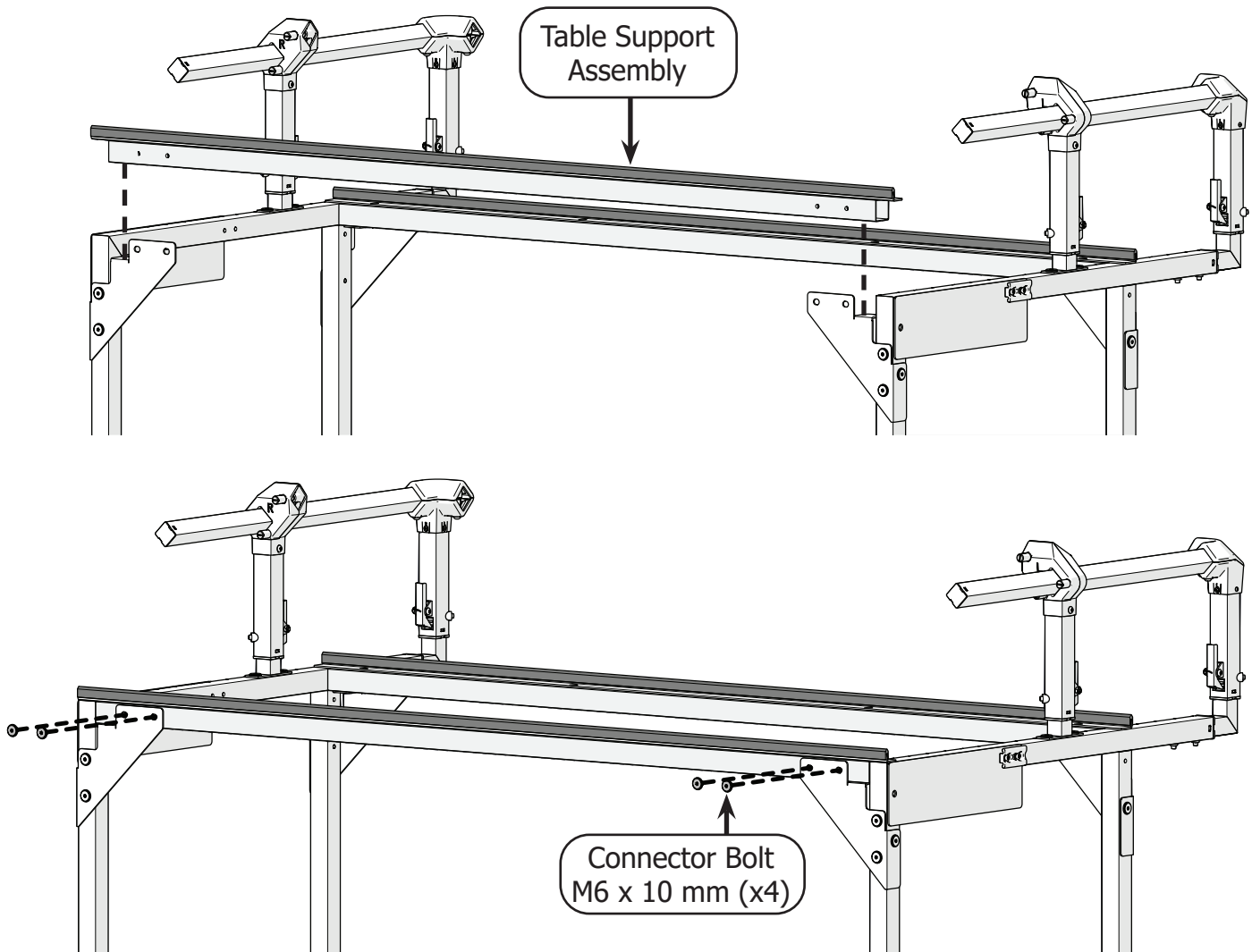

- 4 Now tighten all the **connector bolts** that have been left loose. There are five on each corner bracket, for a total of 20.

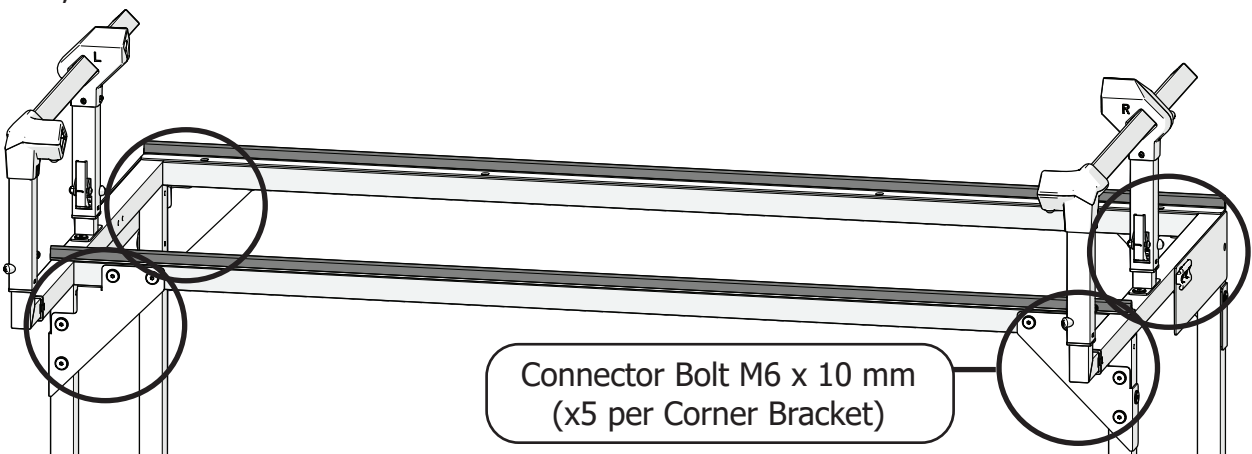

- 5 Result: Frame legs and table supports are tightly assembled.

## Task 4 - Install the Single-Wheel Channel Lock

For details on using the channel locks, see page 47.

### Parts & Tools Needed:

Bottom Carriage

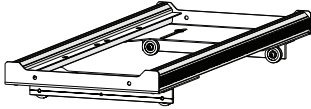

Single-Wheel Channel Lock

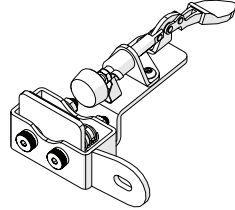

Channel Lock Washer

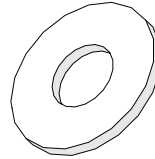

Allen Wrench 4 mm

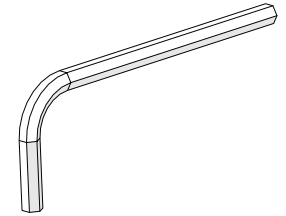

### Instructions

Channel locks restrict the movement of the machine along one axis, so that it is easy to create a straight vertical or horizontal line. The single-wheel channel lock stops the movement of the machine on the side-to-side axis to assist with making vertical lines. Take the following steps:

- 1 Choose which of the two short sides of the bottom carriage will be the **front** and which will be the **back**.

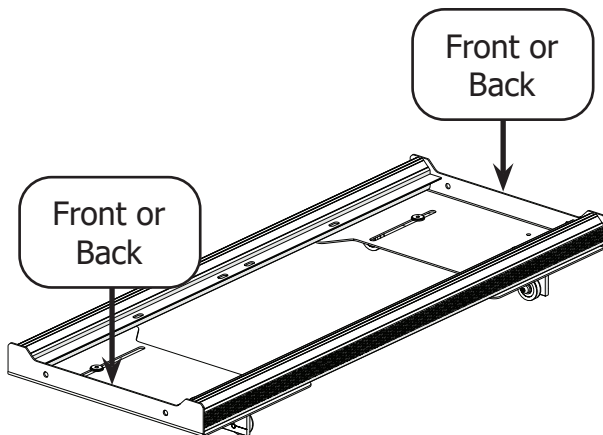

- 2 Turn the **front** side toward you, and then find the **back right** corner.

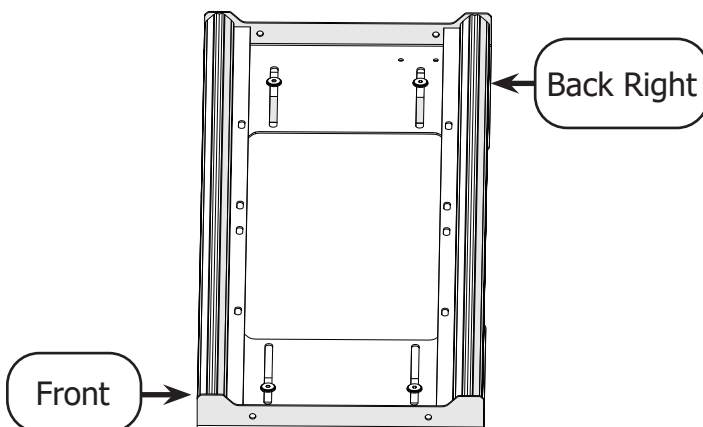

- 3 Use the 4 mm Allen wrench to remove the back right **M6 x 20 mm SBHCS, wheel, and spacer** from the carriage.

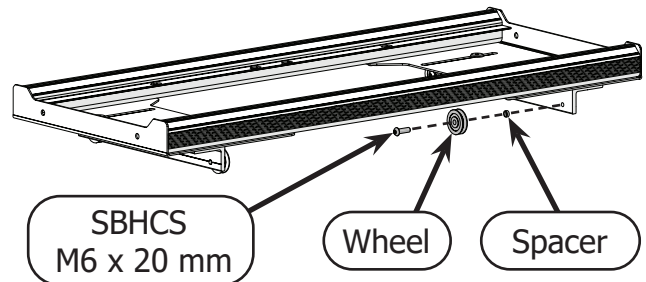

- 4 Install the carriage channel lock with the **M6 x 20 mm SBHCS, wheel, and spacer**. Do not fully tighten the screw.

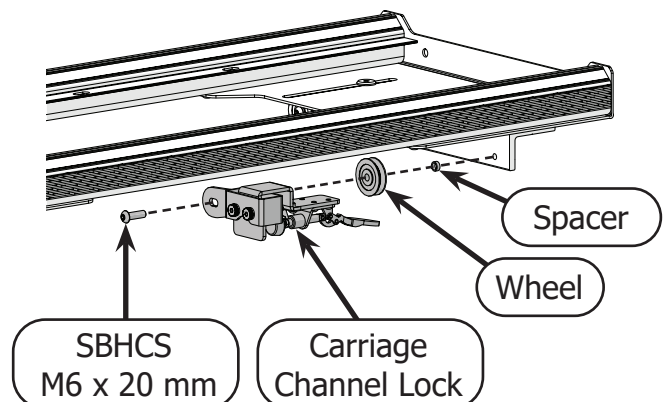

## Task 4 - Install the Single-Wheel Channel Lock (Continued)

- 5 Push the channel lock so it is flush with the side of the **wheel extrusion**. Use the 4 mm Allen wrench to tighten in place.

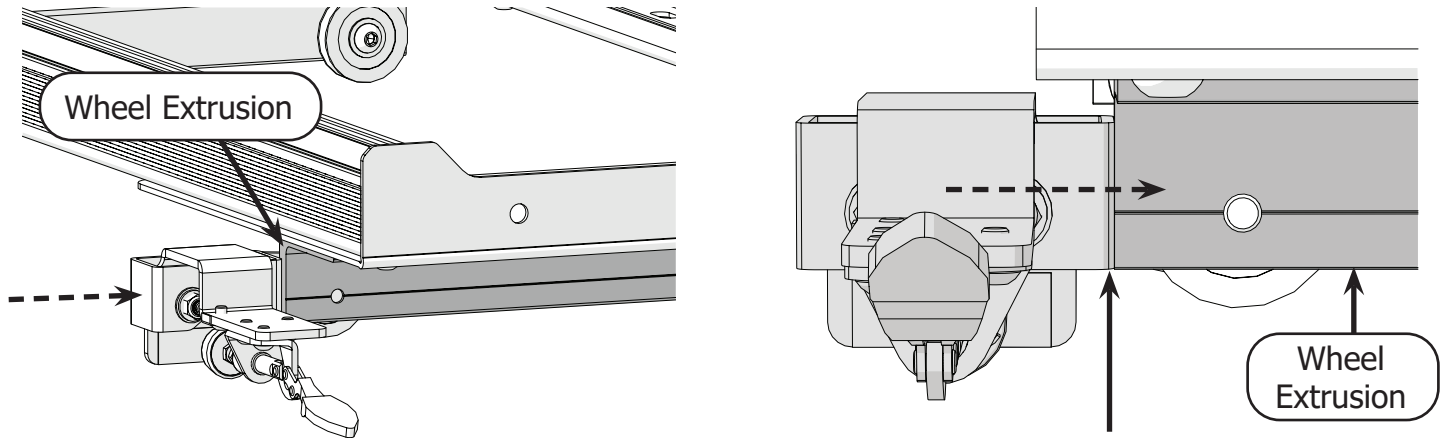

- 6 Place the bottom carriage onto the frame with the **channel lock** at the back.

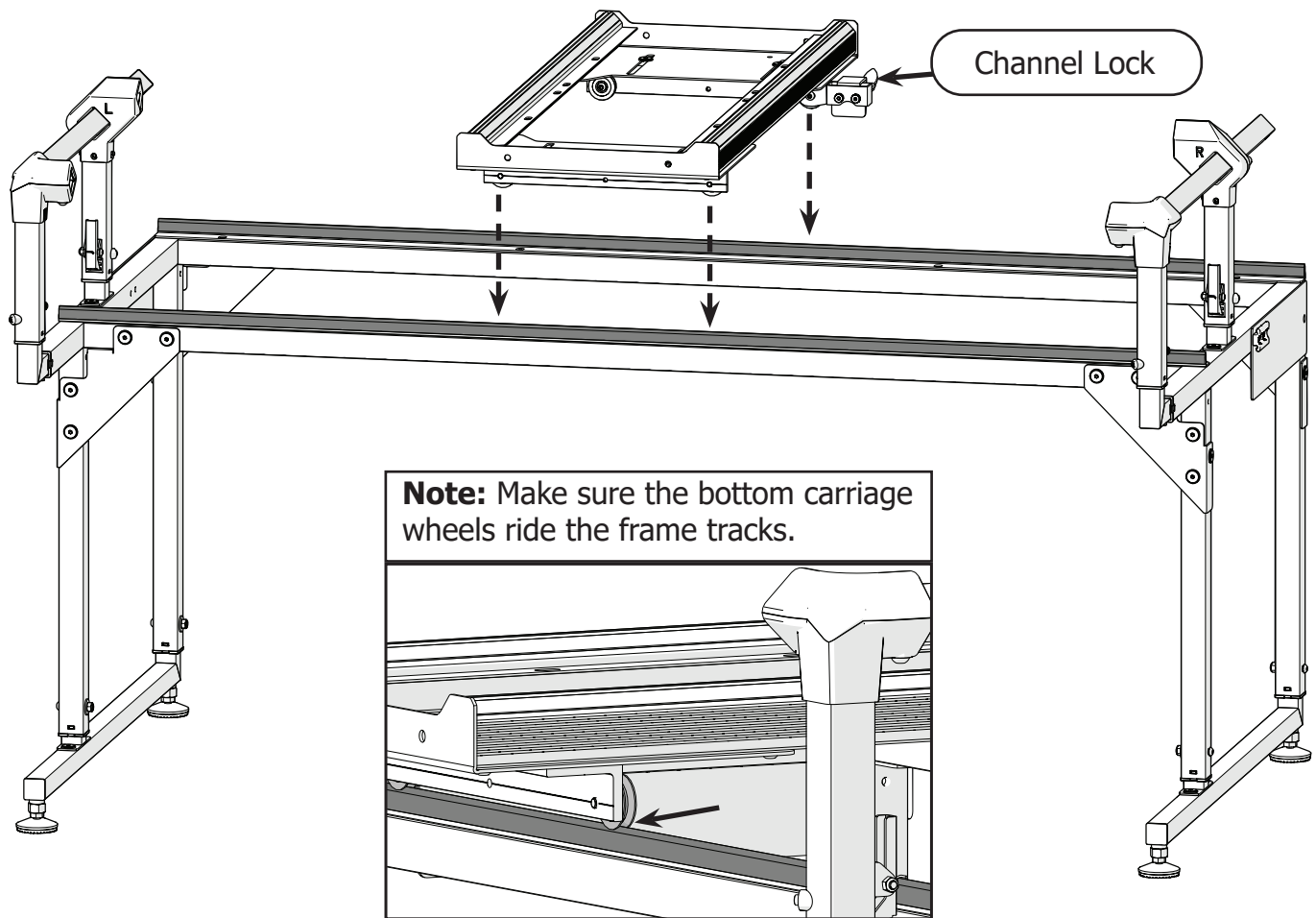

## Task 4 - Install the Single-Wheel Channel Lock (Continued)

- 7 Close the channel lock handle and test it out. The **rubber foot** should press firmly against the frame tracks and prevent the bottom carriage from sliding across the frame.

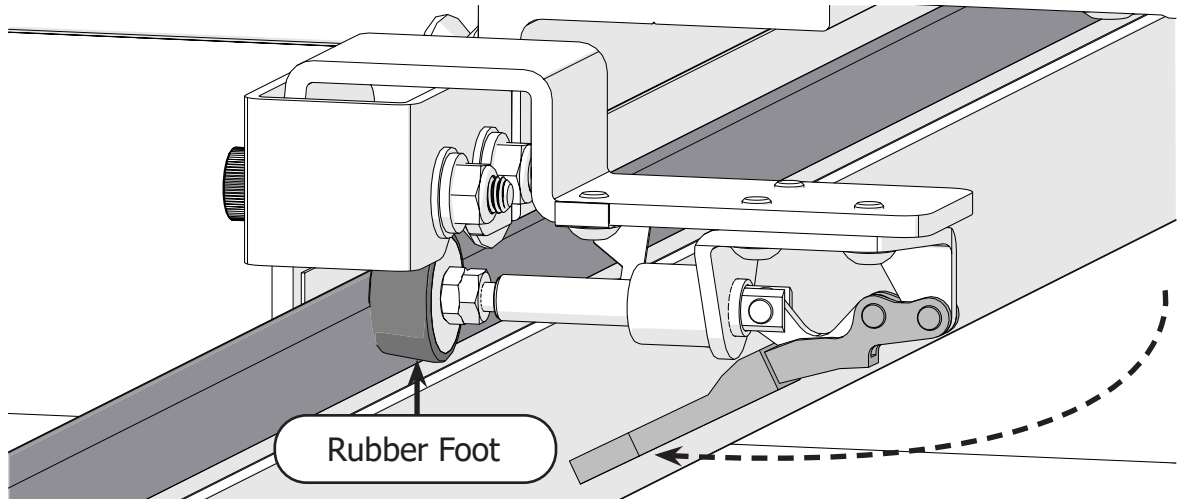

- 8 If the channel lock doesn't fully reach the track, or its grip on the track seems loose, twist the rubber foot clockwise to extend it.

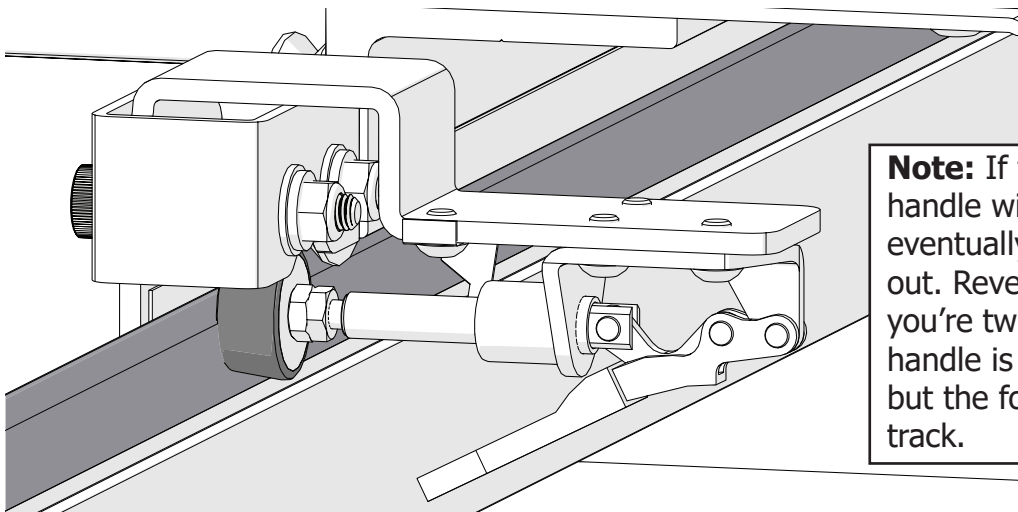

- 9 **Optional step:** Prevent the channel lock from loosening over time by using needle nose pliers or a wrench to tighten the bottom 4 mm **hex nut** against the rubber foot. Tighten the other hex nut against the channel lock **barrel**.

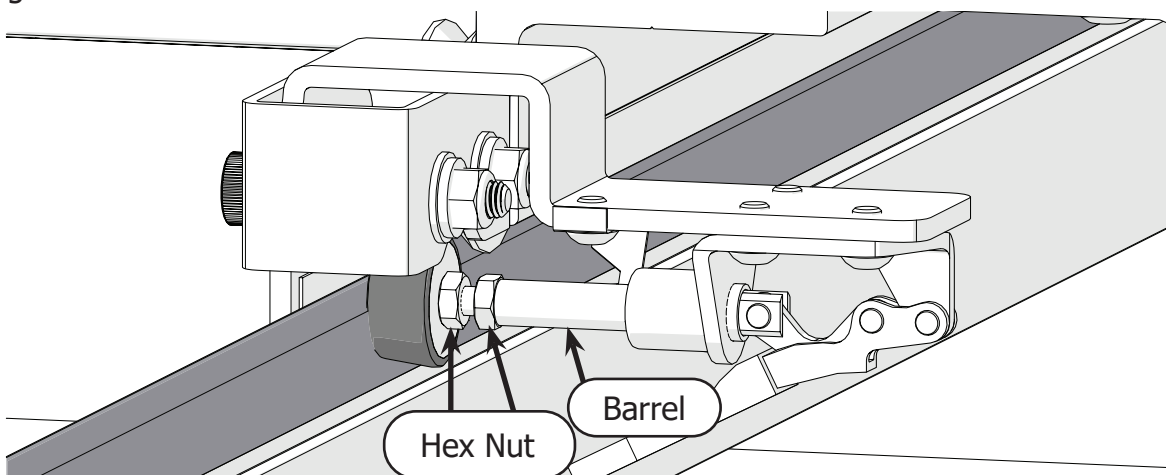

## Task 5 - Align the Tracks

### Parts & Tools Needed:

Allen Wrench  
4 mm

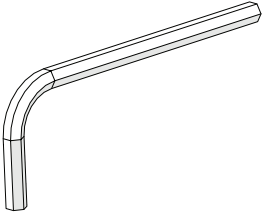

### Instructions

Proper track alignment ensures the smooth motion of the machine across the frame. Take the following steps to align the tracks:

- 1 Loosen the four connector bolts on the front of the table support assemblies. Do not remove.

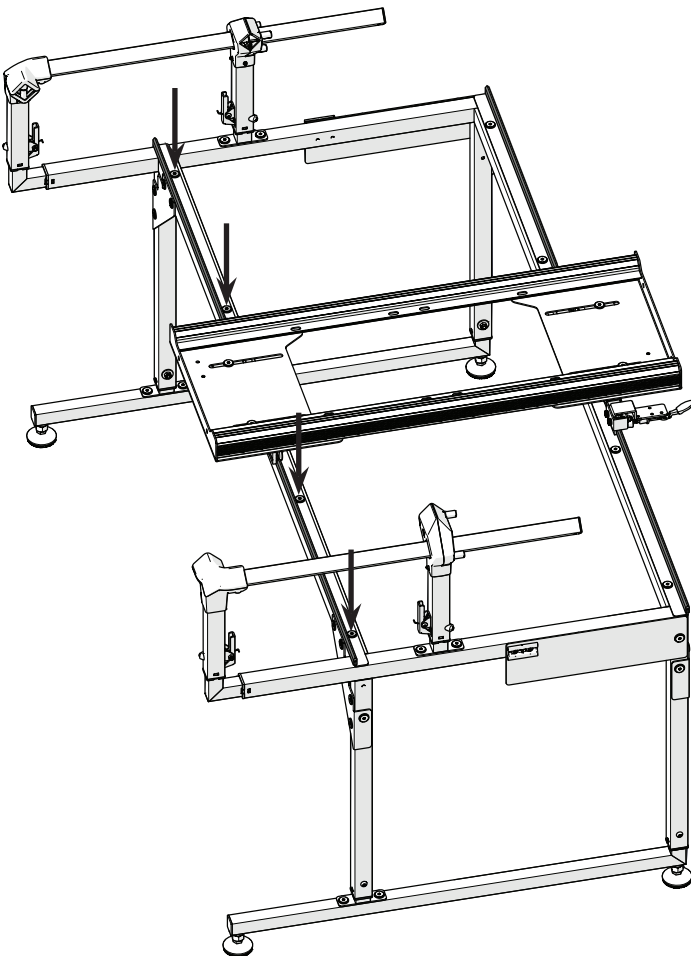

- 2 Roll the bottom carriage to one side of the frame.

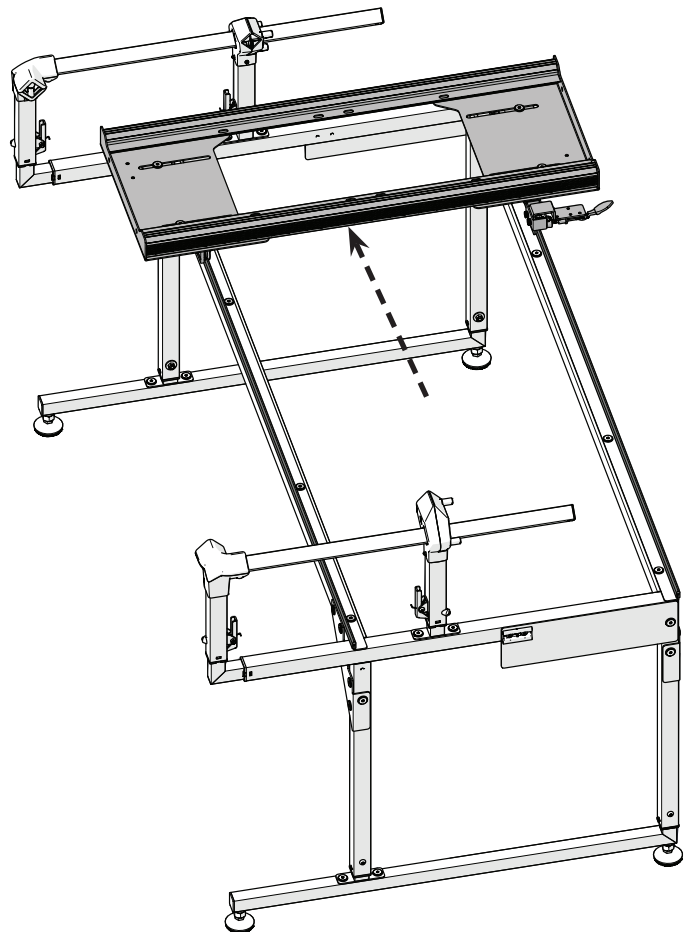

## Task 5 - Align the Tracks (Continued)

- 3 Push down firmly on the bottom carriage and slowly move it across the frame to the other side. This helps straighten the tracks.

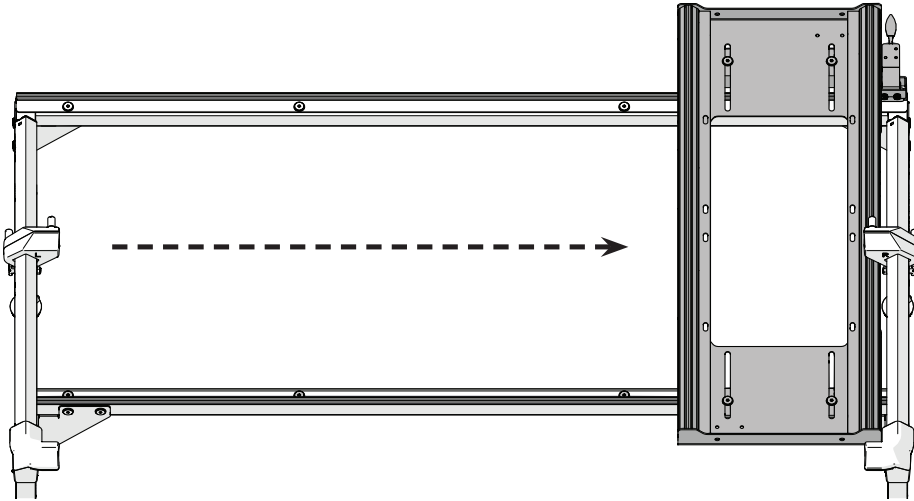

- 4 Push down firmly on the bottom carriage and slowly move it to the other side again. As you pass over each connector bolt, pause to tighten it.

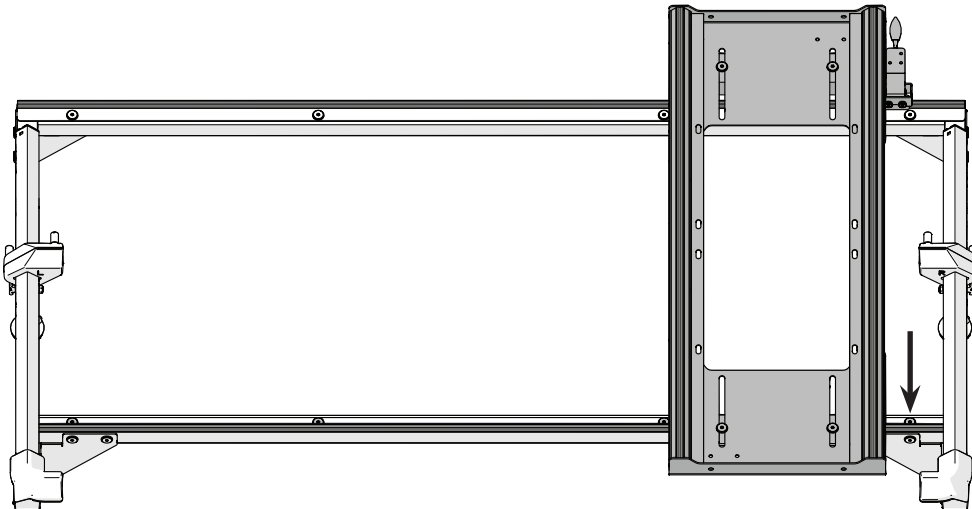

**Note:** The last connector bolt can be tightened when the bottom carriage is just in front of it.

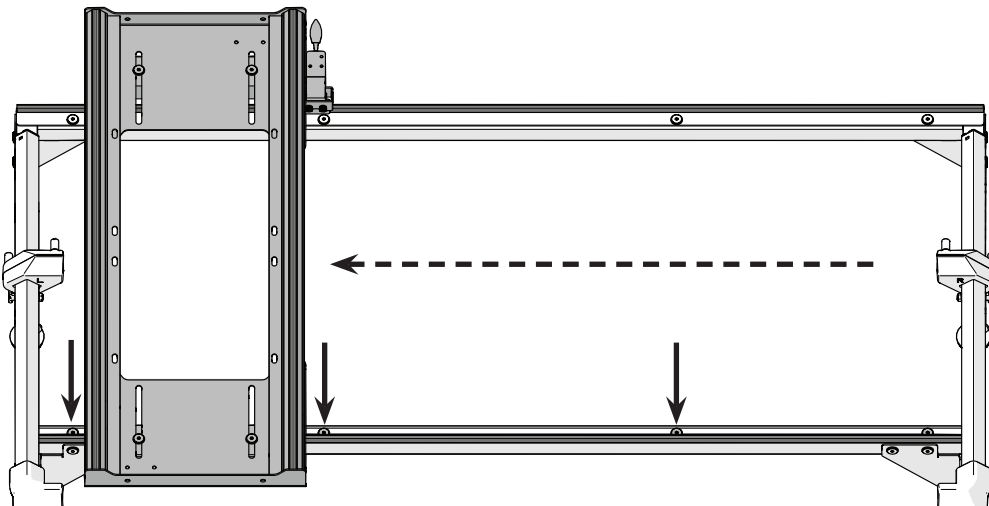



Congratulations! You have completed Part One of the assembly instructions for your frame. Before continuing to Part Two of these instructions, complete any of the following that apply to you:

- **Wheeled quilting machine users:** Complete Part One of your instruction manual and follow the instructions provided at the end of Part One to determine what manual to go to next.  
**Note if your machine manual is not broken into parts, complete the following in order:**
  1. Install the lower encoder on the machine according to your machine's instruction manual.
  2. Complete Part One of your QuiltMotion manual if you will be setting up the QuiltMotion automation accessory today. Otherwise, skip this step.
  3. Complete the steps to install and adjust your machine wheels according to your machine's instruction manual.
  4. Then complete Part Two of your QuiltMotion manual, if applicable.
- **Top plate and wheel-less sewing/quilting machine users:** assemble the top plate now according to your top plate instruction manual. If you'll be using QuiltMotion, complete Part One and Two of your QuiltMotion manual after assembling your top plate.

# Part Two

Before completing the tasks in part two, please ensure you've completed the applicable items listed below.

## **Progress Checkpoint**

Have you:

- Installed the lower encoder onto the bottom carriage (machine manual part one) OR assembled your top plate?  
(Note: If you've assembled your top plate, skip ahead to Part Three on page 21.)
- Completed Part One of QuiltMotion (optional accessory)
- Aligned your machine wheels (machine manual part two)
- Completed Part Two of QuiltMotion (optional accessory)

## Task 6 - Install the Dual-Wheel Channel Lock

### Parts & Tools Needed:

Dual-Wheel  
Channel Lock

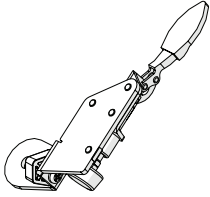

Allen Wrench  
4 mm

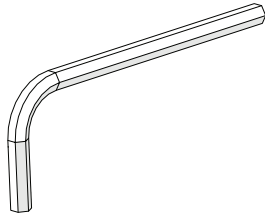

SBHCS  
M6 x 20 mm

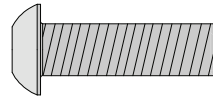

If using a top plate, skip to Part Three on page 21.

For instructions on using the channel locks, see page 47.

### Instructions

Channel locks restrict the movement of the machine or bottom carriage along one axis, so that it is easy to create a straight line. This channel lock is installed on the machine and stops the movement of the machine along the front-to-back axis to assist with making horizontal lines.

- 1 Locate the machine's **right rear wheels**.

**Note:** Machine may differ from model shown.

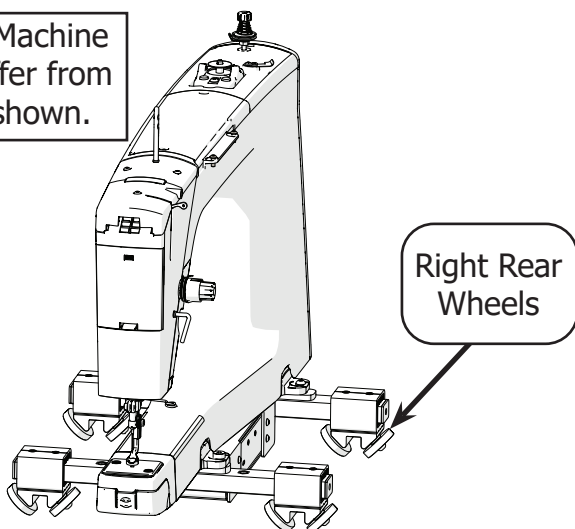

- 2 Use a 4 mm Allen wrench to remove the **outside wheel** and **wheel screw**. The wheel screw will not be needed again and can be stored with the packaging materials.

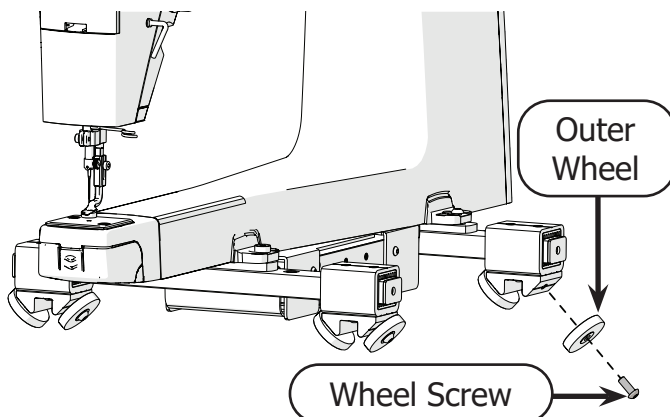

- 3 Place the **dual-wheel channel lock** onto the **M6 x 20 mm SBHCS**. Follow it with the wheel, with the **wheel hub** facing away from the channel lock.

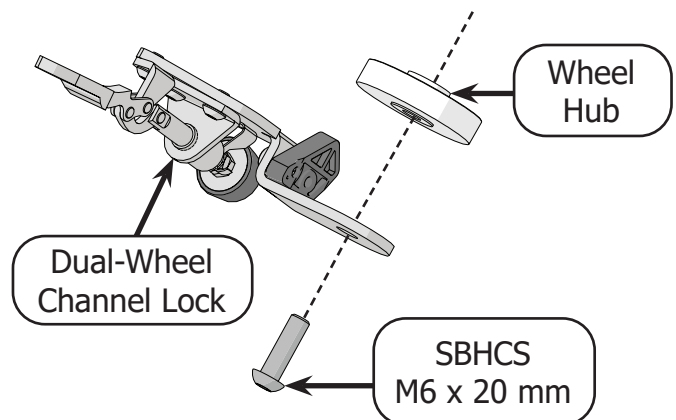

- 4 Screw the channel lock and wheel onto the machine so the channel lock body is toward the front of the machine. Use a 4 mm Allen wrench to attach.

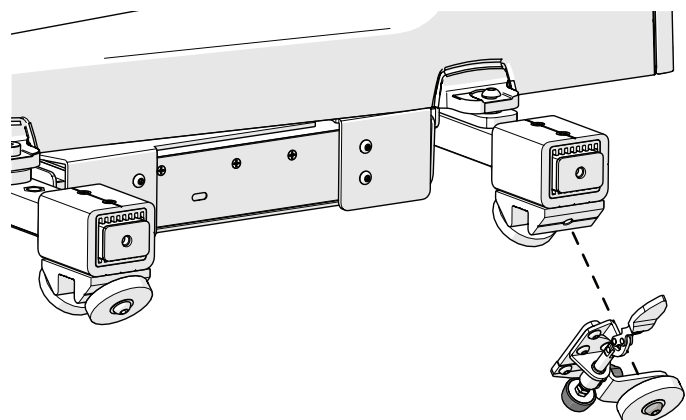

## Task 6 - Install the Dual-Wheel Channel Lock (Continued)

- 5 Close the channel lock handle and test it out. The **rubber foot** should press firmly against the bottom carriage tracks and prevent the machine from moving front-to-back on the carriage.

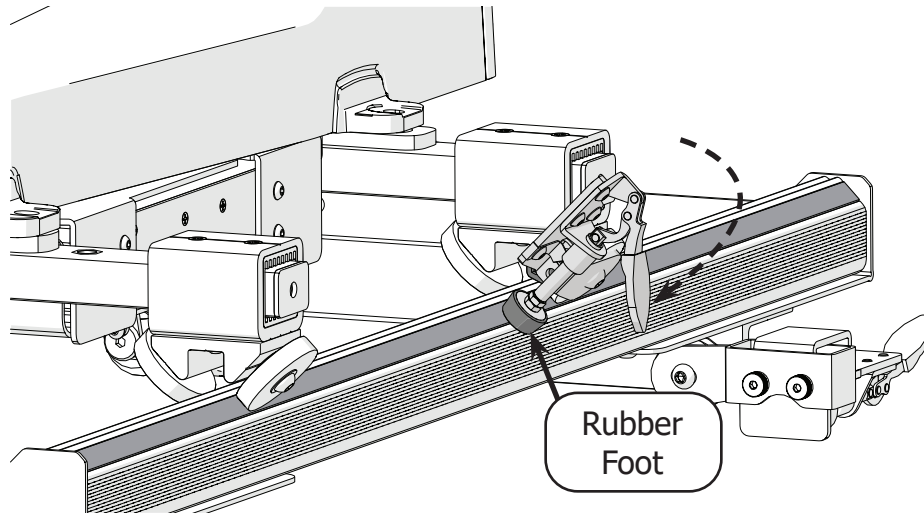

- 6 If the channel lock doesn't fully reach the track, or its grip on the track seems loose, twist the rubber foot clockwise to extend it.

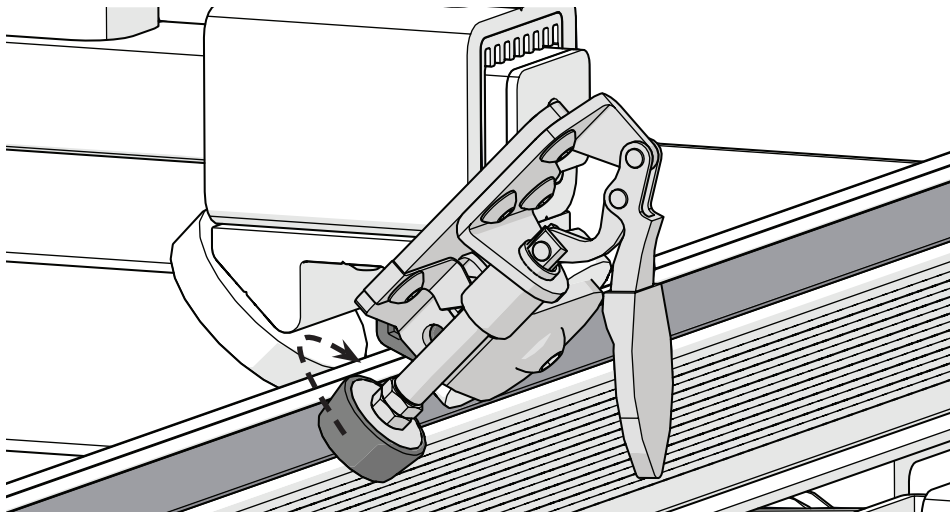

**Note:** If twisted too far, the handle will start to open, and eventually the foot will fall out. Reverse the direction you're twisting until the handle is pointing down, but the foot still reaches the track.

- 7 **Optional step:** Prevent the channel lock from loosening over time by using needle nose pliers or a wrench to tighten the bottom 4 mm **hex nut** against the rubber foot. Tighten the other hex nut against the **channel lock barrel**.

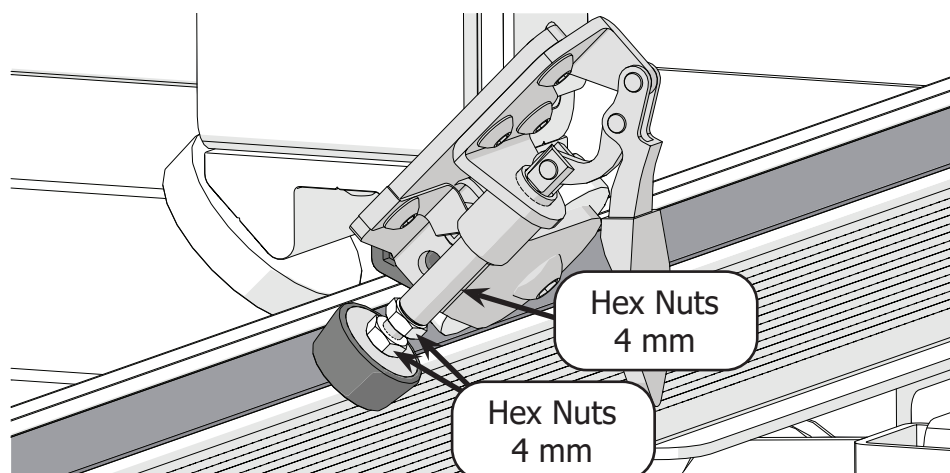

Congratulations! You have completed Part Two of the assembly instructions for your frame. Before continuing to Part Three of these instructions, complete any of the following that apply to you:

- **Wheeled quilting machine users:** Complete Part Three of your instruction manual.  
**Note if your machine manual is not broken into parts, complete the following in order:**
  1. Install the machine wheel covers.
  2. Install the handlebars (applicable machines only).
  3. Install the display.
  4. Install the thread stand (applicable machines only).
  5. Install the upper encoder onto the machine.
  6. Plug in the machine.
  7. Wind a bobbin and thread the machine.

# Part Three

Before completing the tasks in part three, complete part three of your machine manual.

## **Progress Checkpoint**

Wheeled quilting machine users:

Have you:

- Completed Part Three of your machine instruction manual:
  - Installed wheel covers (applicable machines only)?
  - Installed handlebars (applicable machines only)?
  - Installed display?
  - Installed thread mast?
  - Installed upper encoder?

Top Plate Users:

Have you:

- Assembled your top plate?
- Installed the channel lock on the top plate?
- Installed and secured your sewing machine on the top plate?

## Task 7 - Install the Rails

### Parts & Tools Needed:

Back  
Long Rail



Hoop Front  
Rail



Allen Wrench  
4 mm

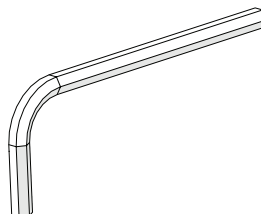

### Instructions

The frame rails hold your quilt fabric. Take the following steps to install the frame rails:

- 1 Use the 4 mm Allen wrench to remove the four **M6 x 25 mm SBHCS** holding the rail corner covers.

Frame (Left Side)

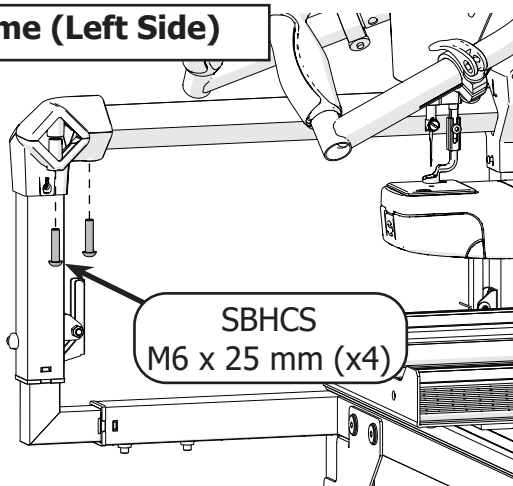

Frame (Right Side)

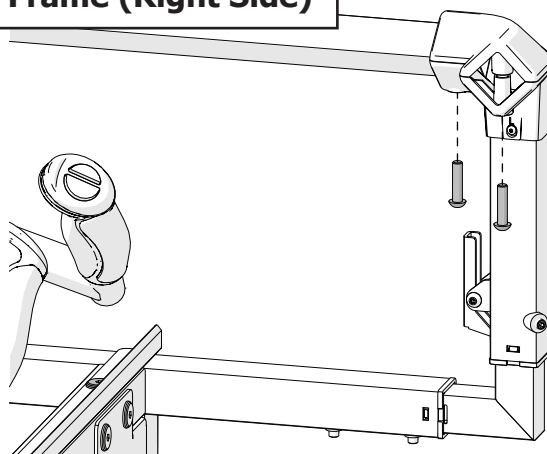

- 2 Lift up the **rail corner covers**.

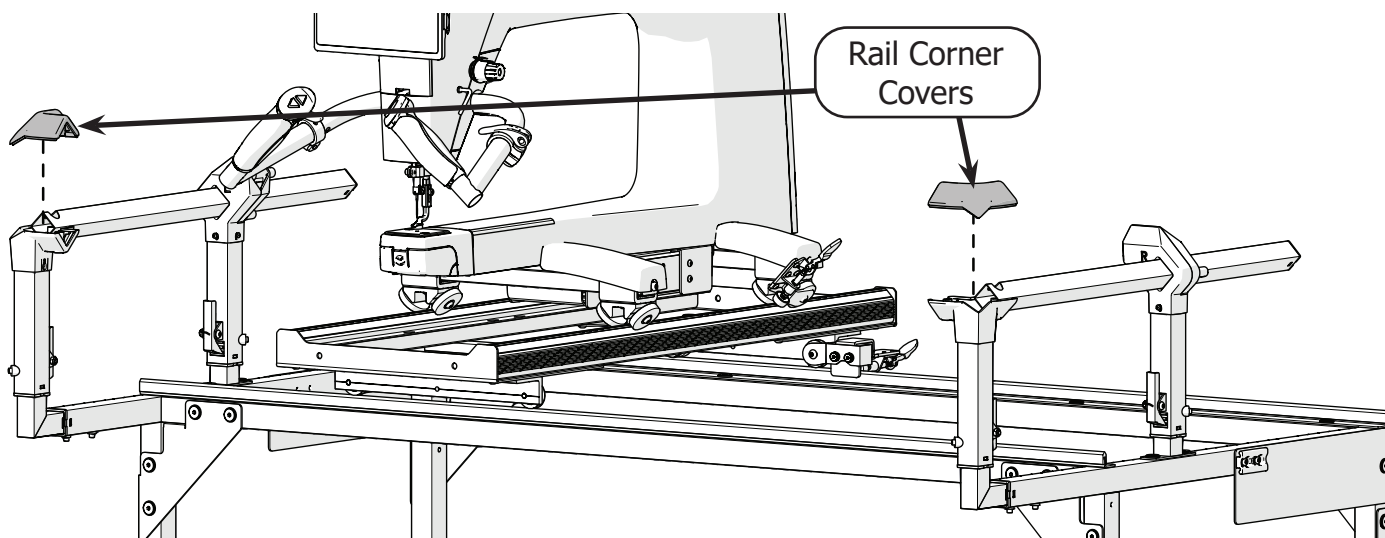

Task 7 - Install the Rails (Continued)

- 3 Place the **hoop front rail** onto the front rail holders so the large holes on the rail are on top.

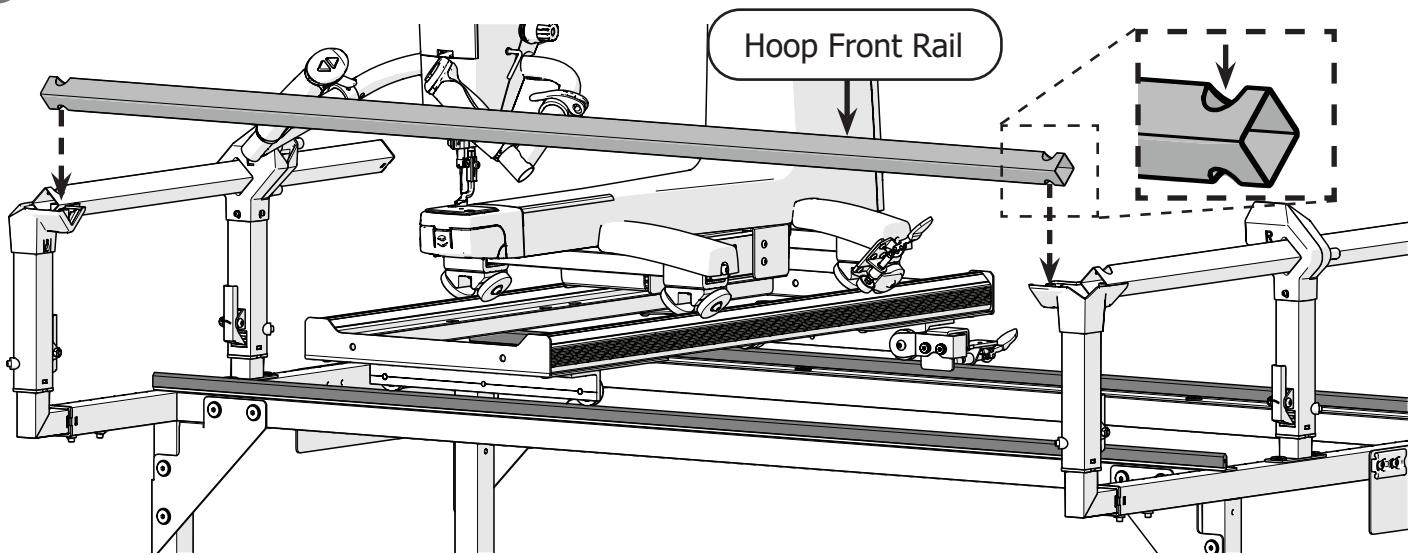

**Note:** The pegs in the rail holders will slide into the rails.

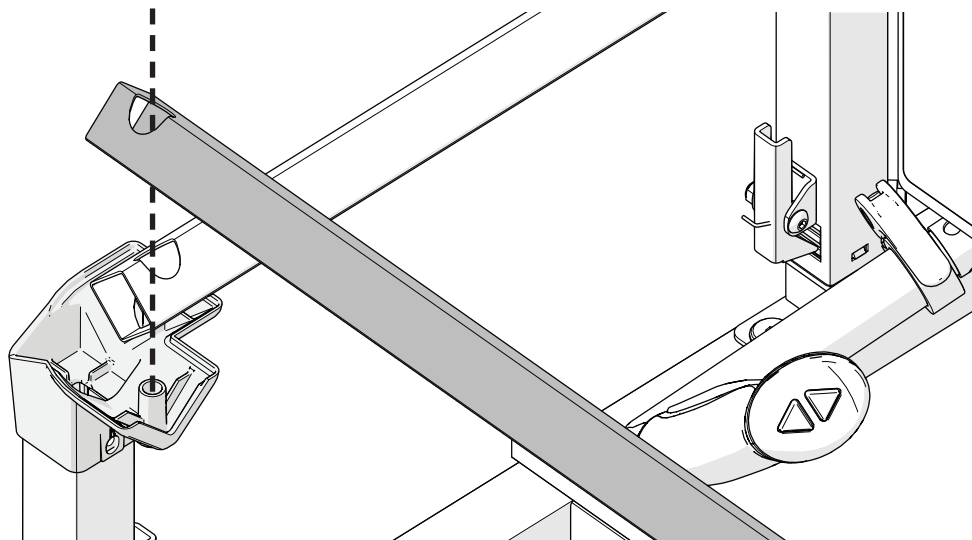

- 4 Re-install the corner covers and four M6 x 25 mm SBHCS screws.

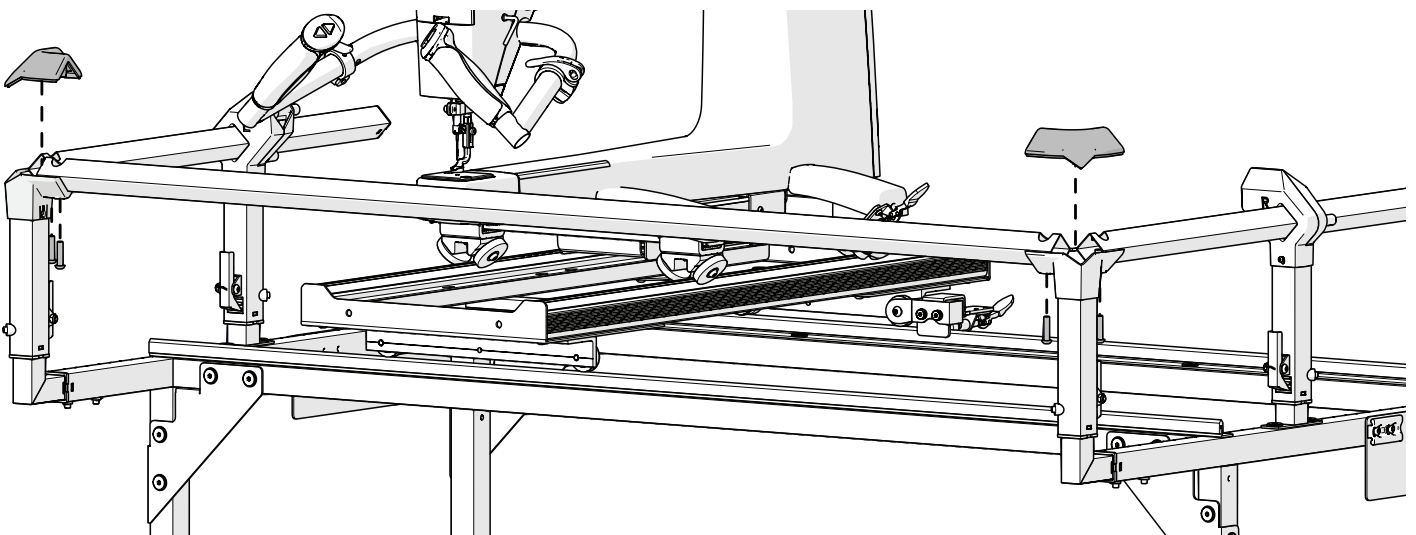



## Task 7 - Install the Rails (Continued)

- 5 Remove the **thumb screws** on the back rail corners.

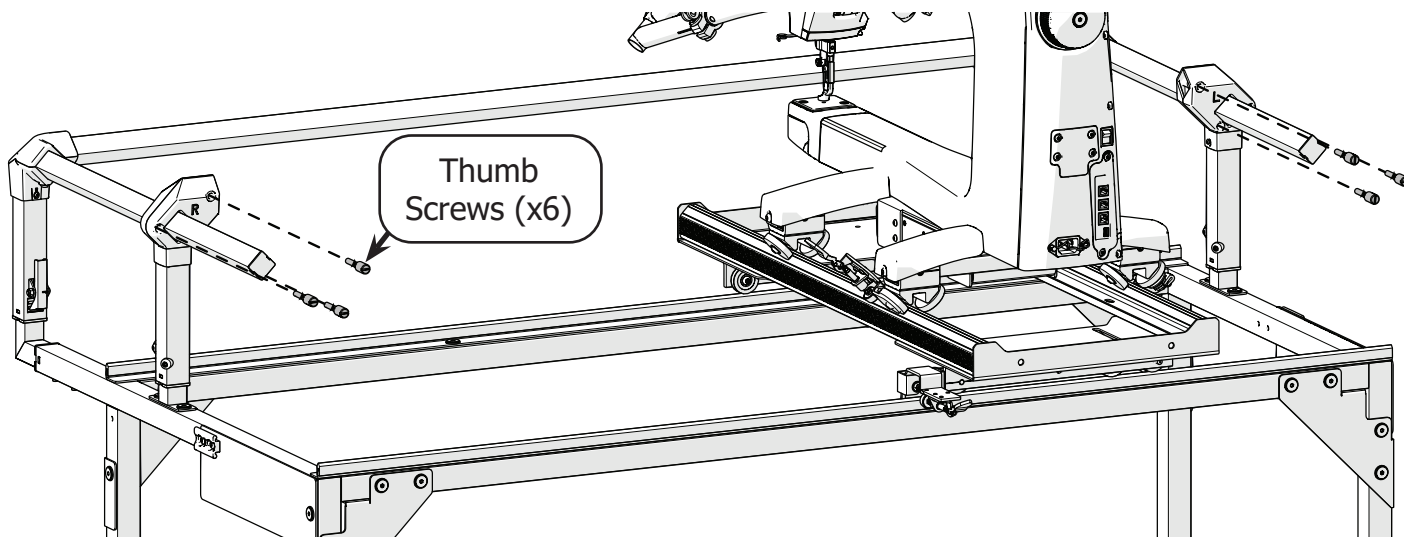

- 6 Remove the **back corner rail covers**.

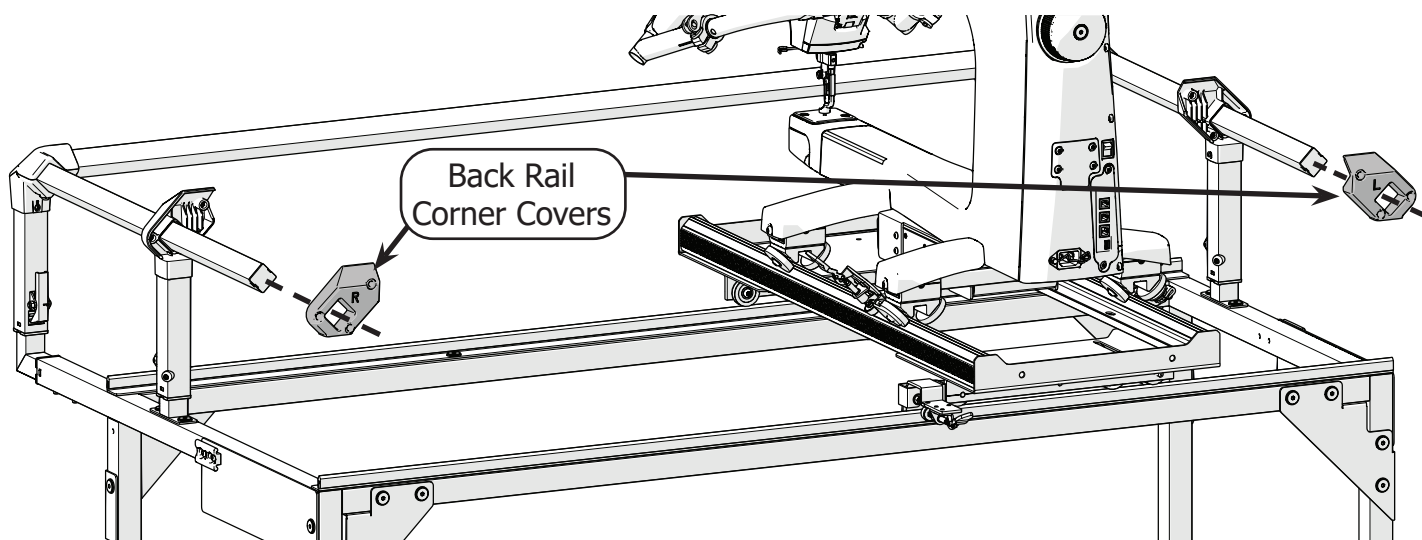

- 7 Slide the **long back rail** through the throat of the machine.

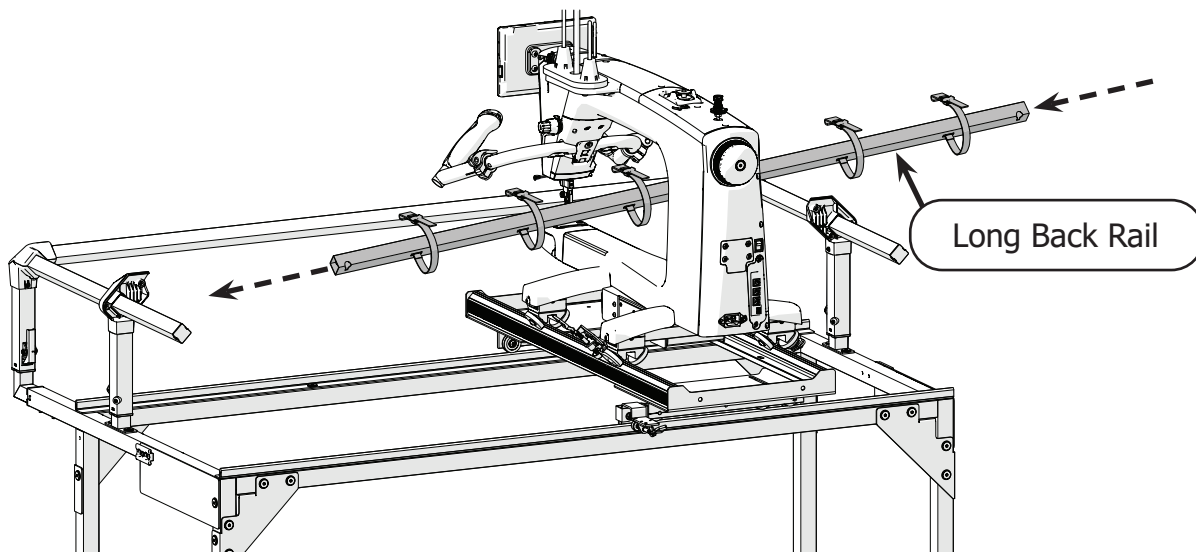

Task 7 - Install the Rails (Continued)

- 8 Place the long back into the back corner cover so the **fabric straps** dangle toward the back of the rail.

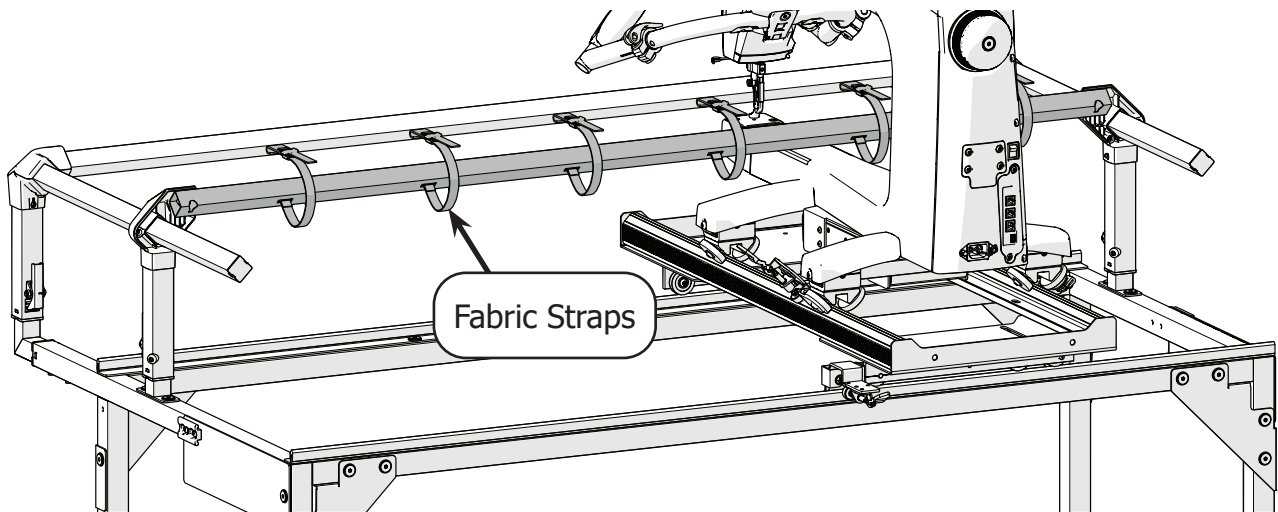

**Note:** The pegs in the rail holders must align with the holes in the rail.

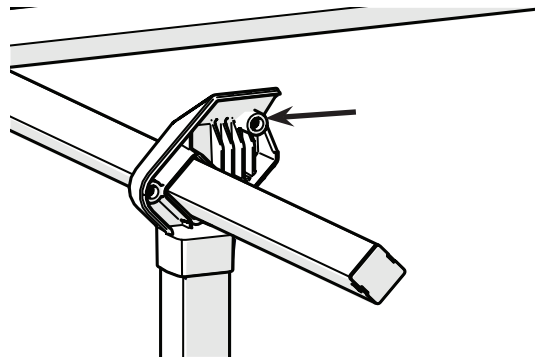

- 9 Clamp the long back rail into place with the back rail corner covers and thumb screws.

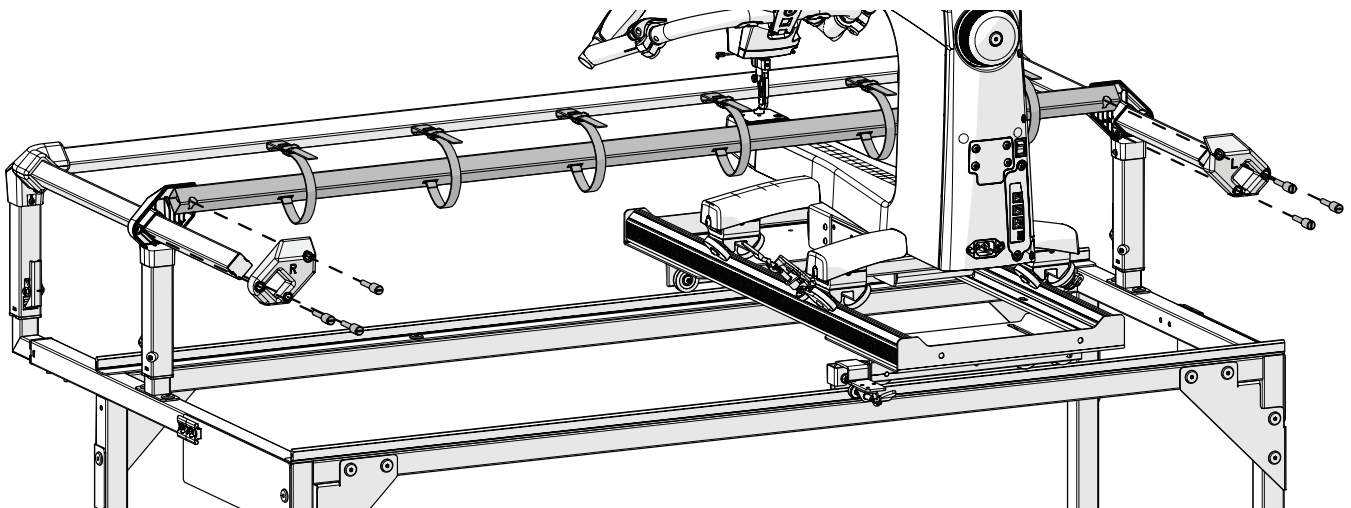

## Task 8 - Set Rail Height

### Parts & Tools Needed:

Allen Wrench  
4 mm

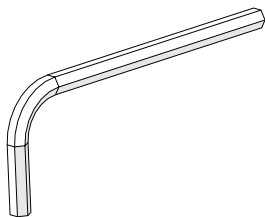

### Instructions

The height of the fabric in relation to the machine is critical in maintaining both fabric and thread tension while quilting. It is important to set the height and distance of the frame rails according to the dimensions of the sewing machine you're using. Take the following steps to set the rail height:

- 1 Find the **throat space** of your machine. Mid and long-arm machines advertise throat-space prominently, but if you're not sure, measure the distance from the needle to the back of the throat.
- 2 Loosen the **set screws** on both of the frame's sides using the 4 mm Allen wrench.

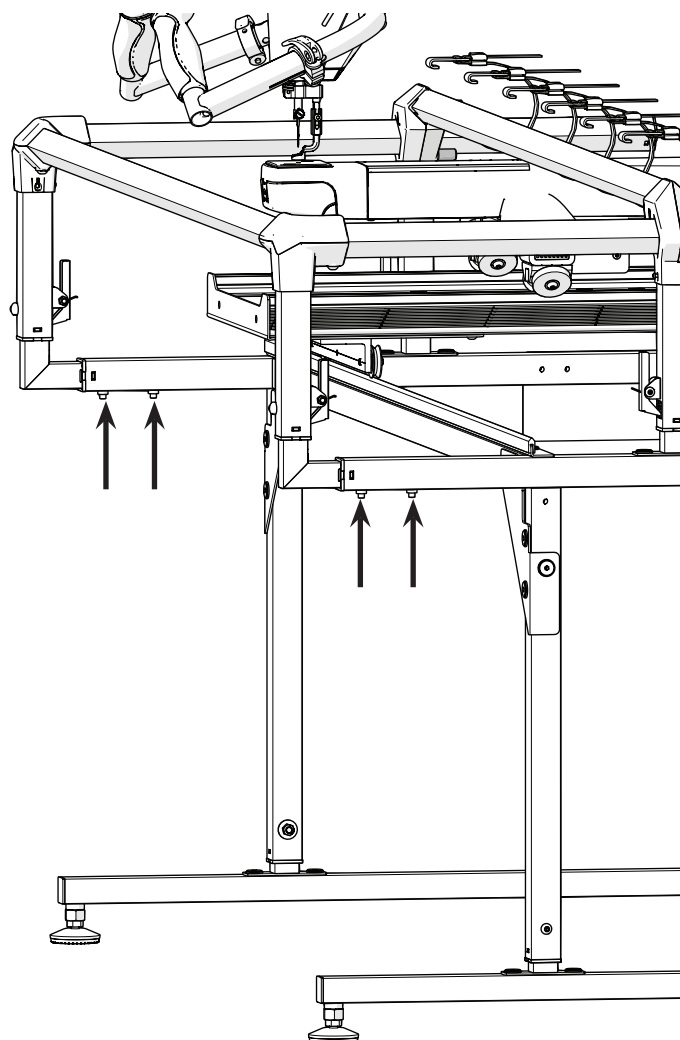
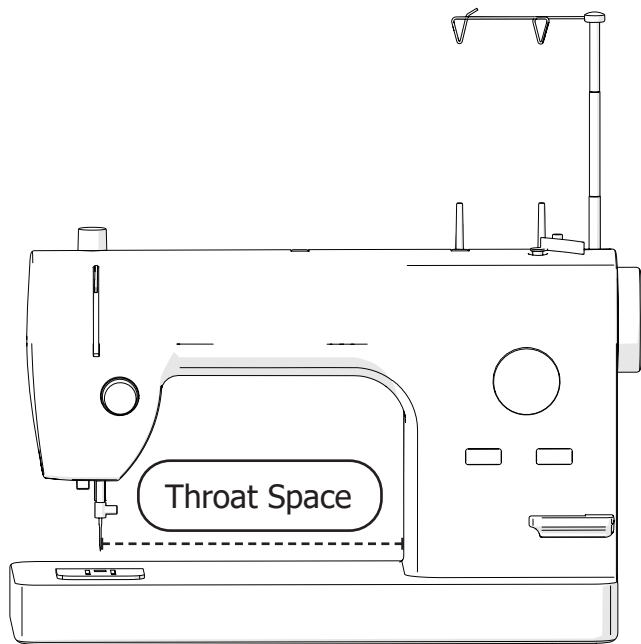

## Task 8 - Set Rail Height (Continued)

### 3 Expand the frame side:

- For machines under 16" in throat space, extend so that the first slot is just visible.
- For machines 16" in throat space or more, extend so the second slot is just visible.

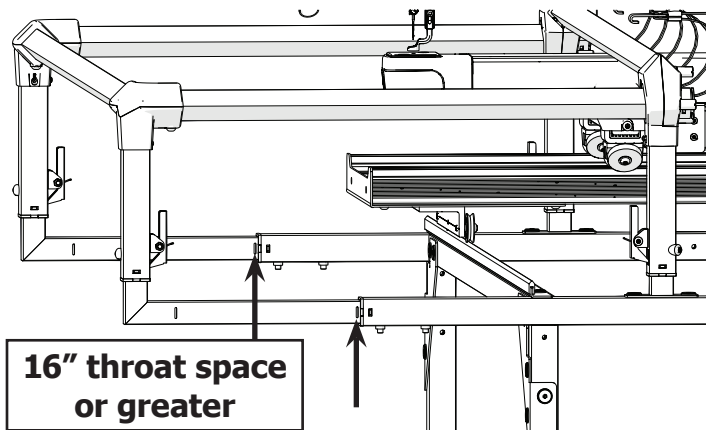
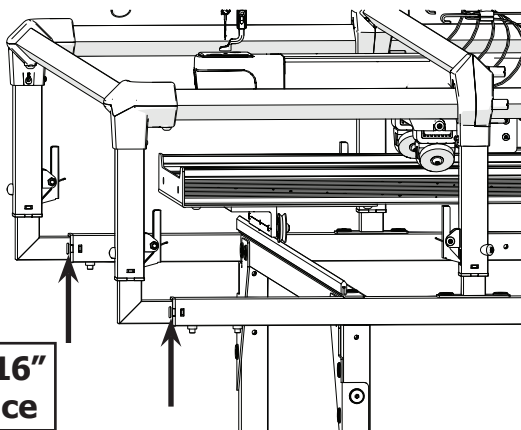

### 4 Re-tighten all four set screws with the 4 mm Allen wrench.

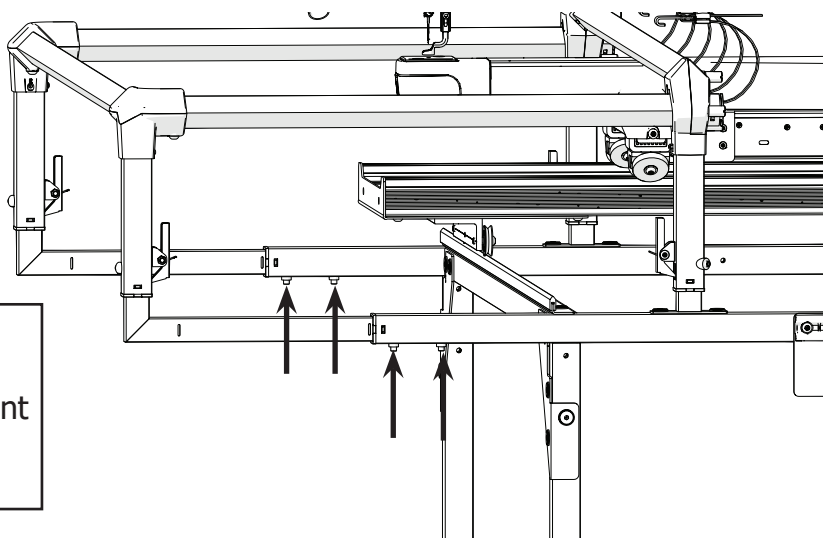

### 5 Loosen the four set screws on the vertical hoop tubes.

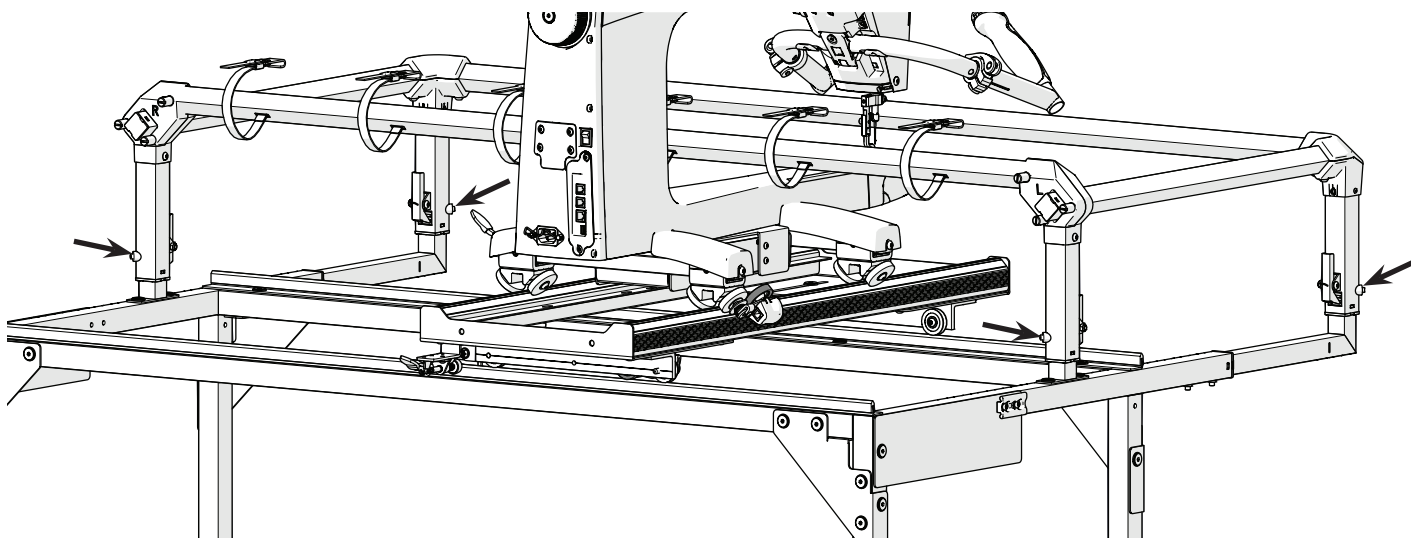

## Task 8 - Set Rail Height (Continued)

- 6 It's easiest to adjust the height of the hoop one corner at a time. Move the machine to the left side of the frame, and bring it as far forward as it will go.

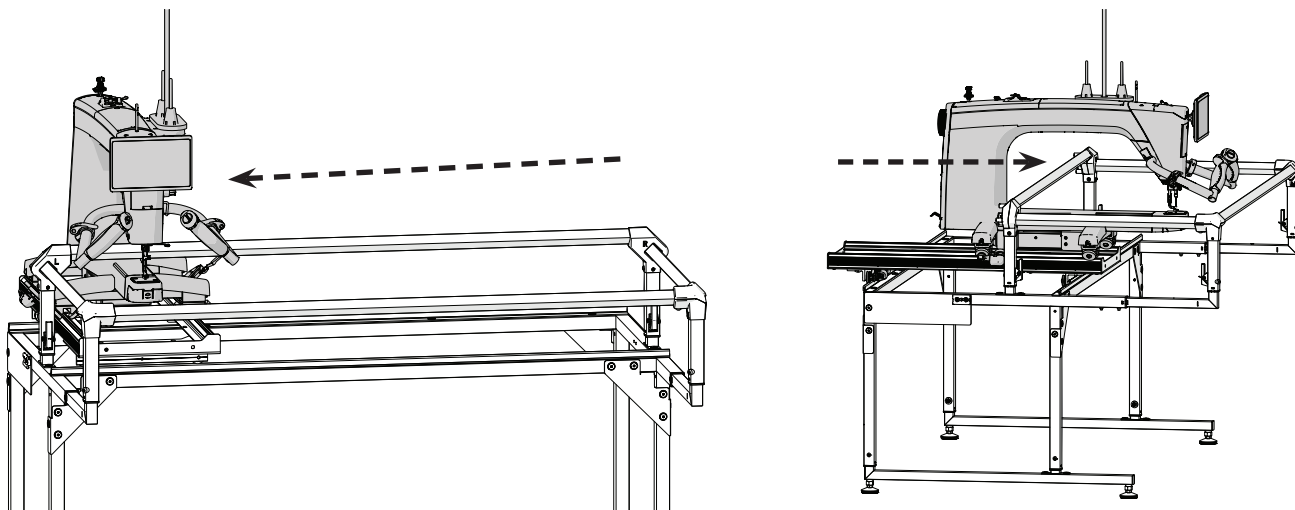

- 7 With the machine still at the left of the frame, press in the **left rear height lever** and adjust the back rail so it is about **1/4th inch** from the surface of the machine bed.

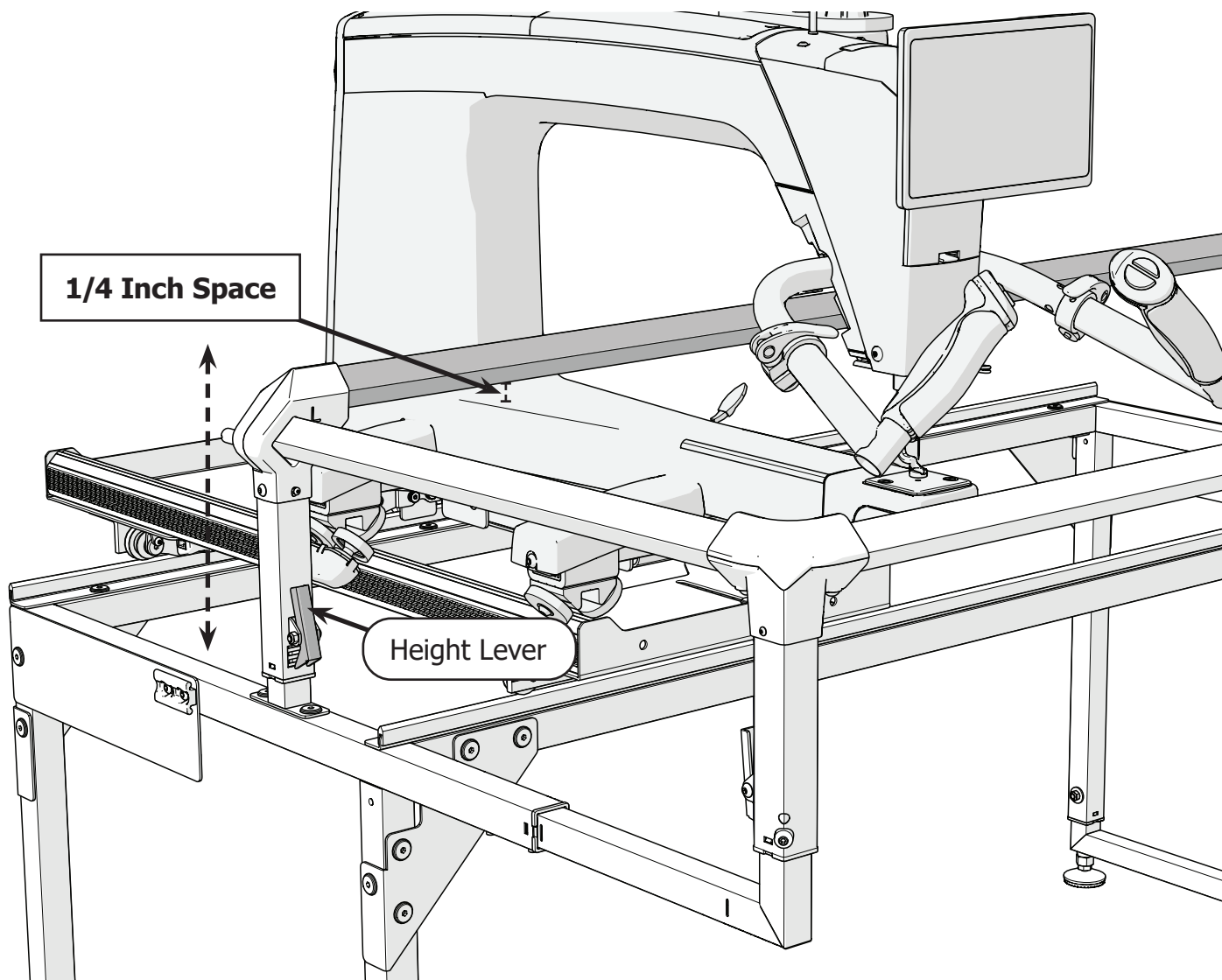

Task 8 - Set Rail Height (Continued)

- 8 Set the other three height levers to the same **height hole** as the one you just set.

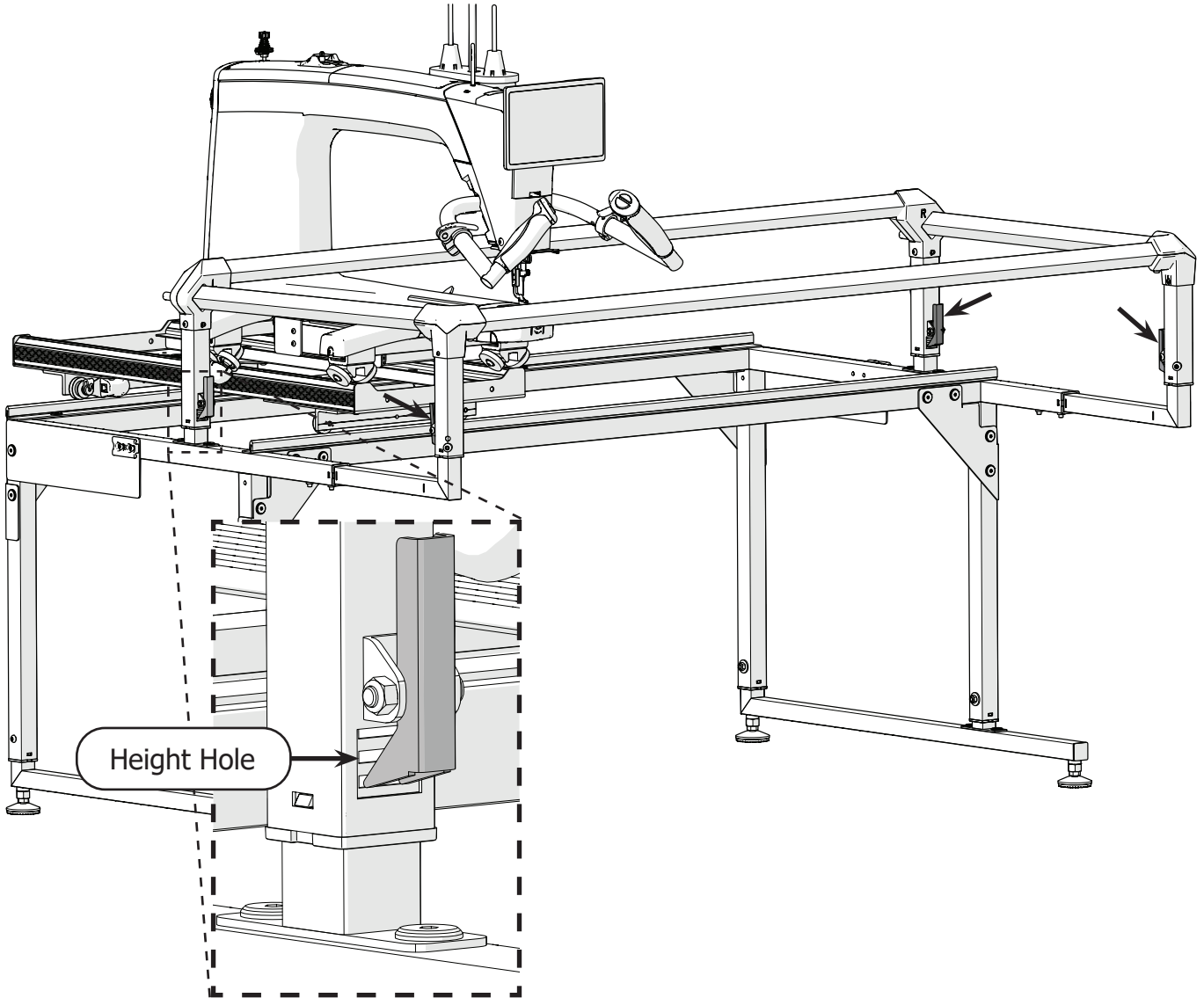

- 9 Re-tighten the four set screws with the 4 mm Allen wrench.

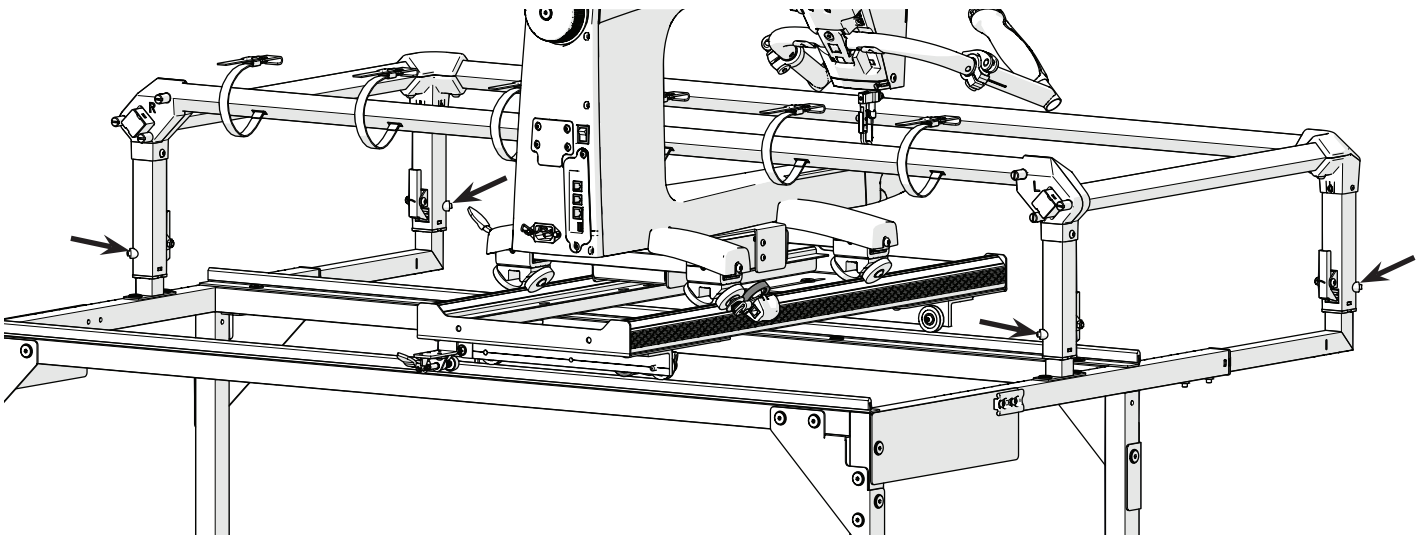



## Task 9 - Install the Fabric Bungees

### Parts & Tools Needed:

Bungee  
Mount (x4)



Bungee  
Clamps (4 pack)



### Instructions

The bungees maintain quilt tension when the edge of the quilt doesn't reach all the way to the side rails. Take the following steps to install the bungees:

- 1 Slide two **bungee mounts** onto the mount holders on each side of the frame, flat sides face-up. This is a convenient place to keep the bungee mounts when you're not using the bungees.

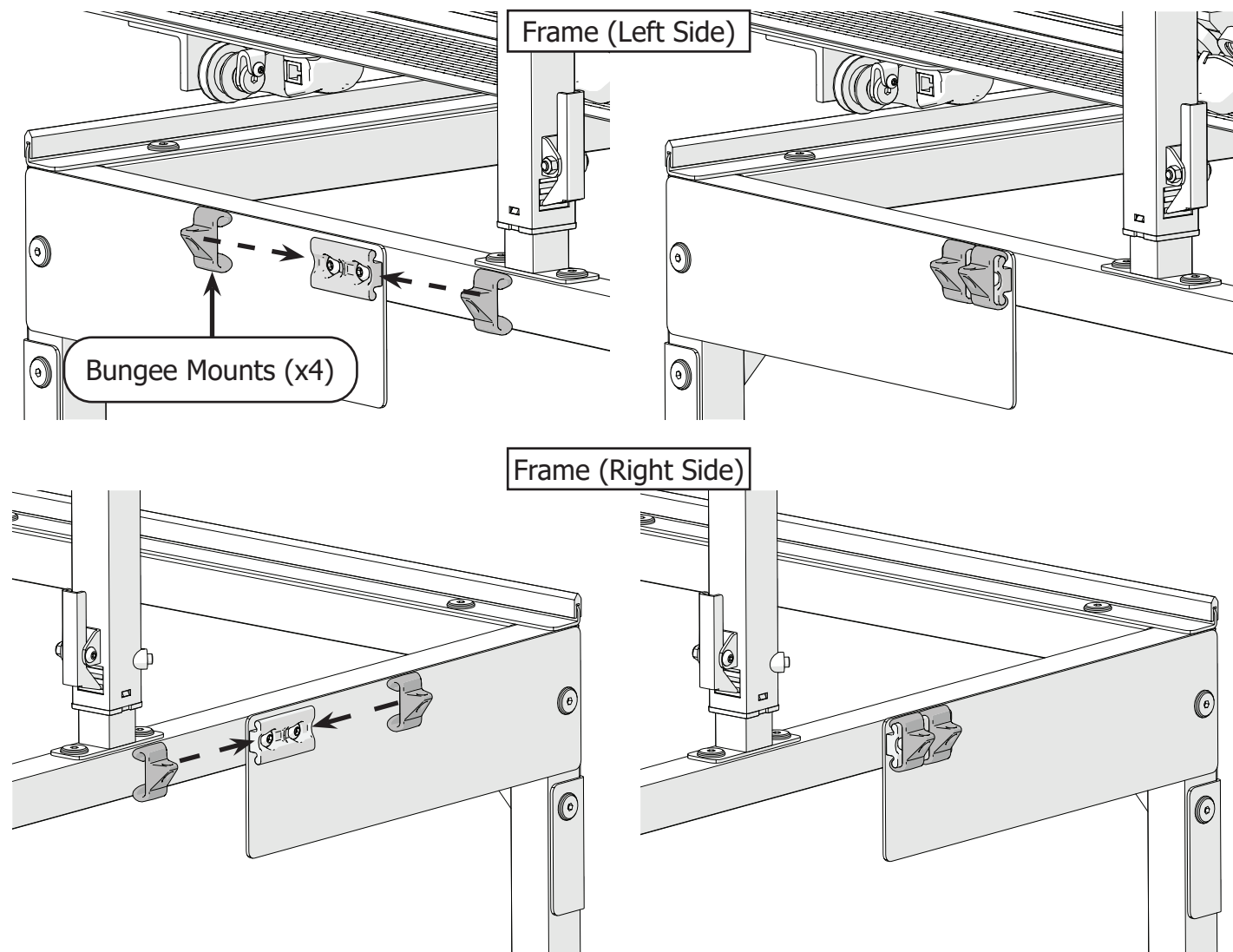

## Task 9 - Install the Fabric Bungees (Continued)

- 2 Press down on the button on the bungee stop and then slide it off the bungee cable.

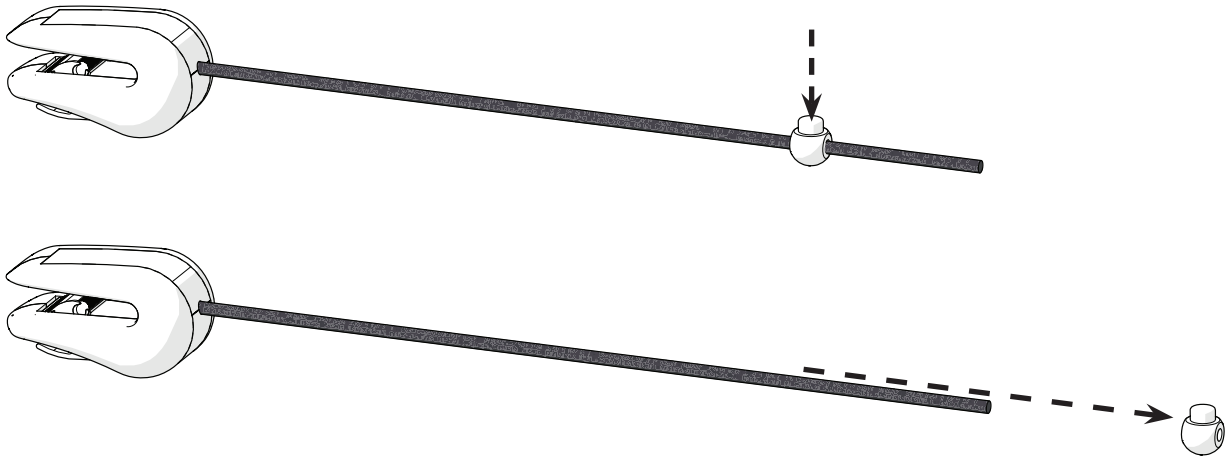

- 3 Thread the bungee cable up through the bungee mount. Press down on the bungee stop, and slide it over the bungee cable to secure the bungee.

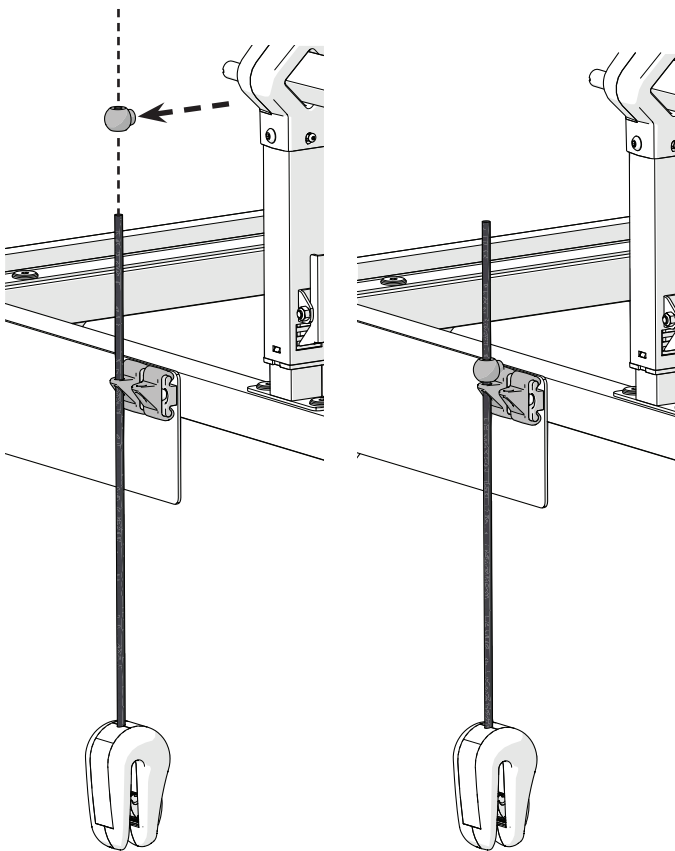

- 4 Repeat steps two and three for the remaining three bungees.

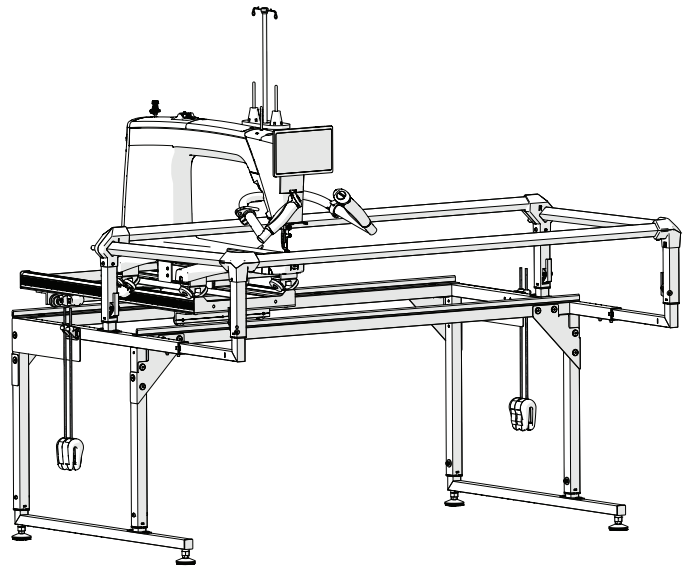

**Note:** For information on using the bungees, see "Using the Bungees" on page 42.



## Task 10 - Level the Frame

### Parts & Tools Needed:

Open-End Wrench  
10 mm & 13 mm

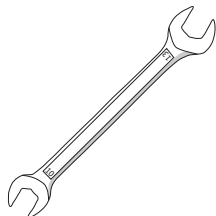

Open-End Wrench  
14 mm & 17 mm

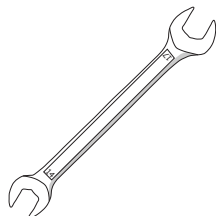

### Instructions

Not all floors are even, and you don't want your machine running away from you while you're quilting! Take the following steps to level your frame:

- 1 Lower all four **leveling feet** to the lowest position by loosening the **top nut** over the leveling foot with the 17 mm Open-end wrench as far as it will go. **Note:** If it does not loosen, the foot is already in the lowest position and you can skip to step 2.

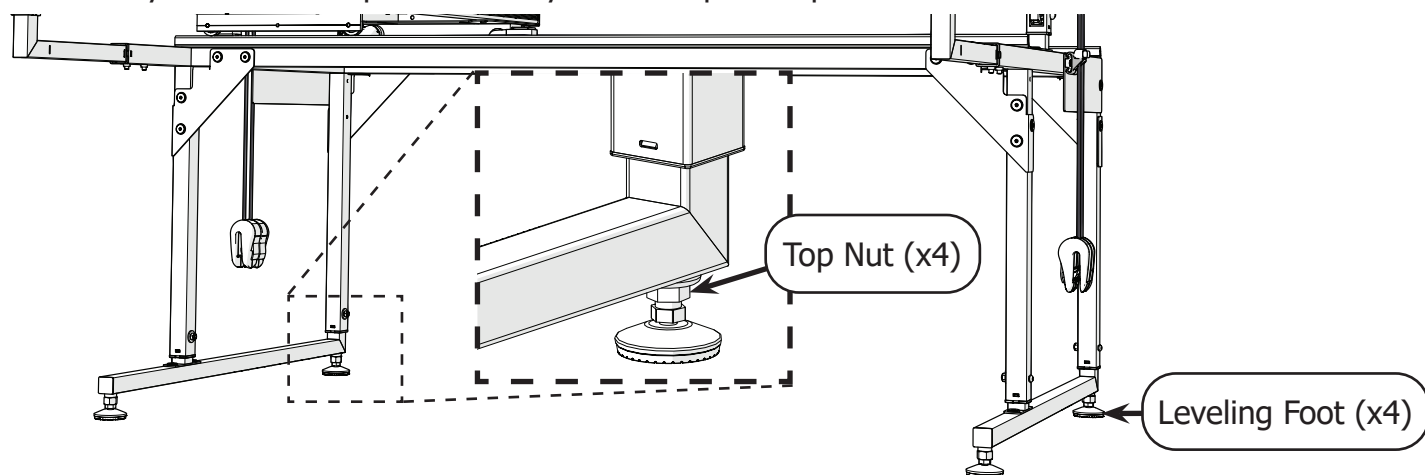

Then turn the lower nut counter-clockwise with the 14 mm side of the open-end wrench on all four feet.

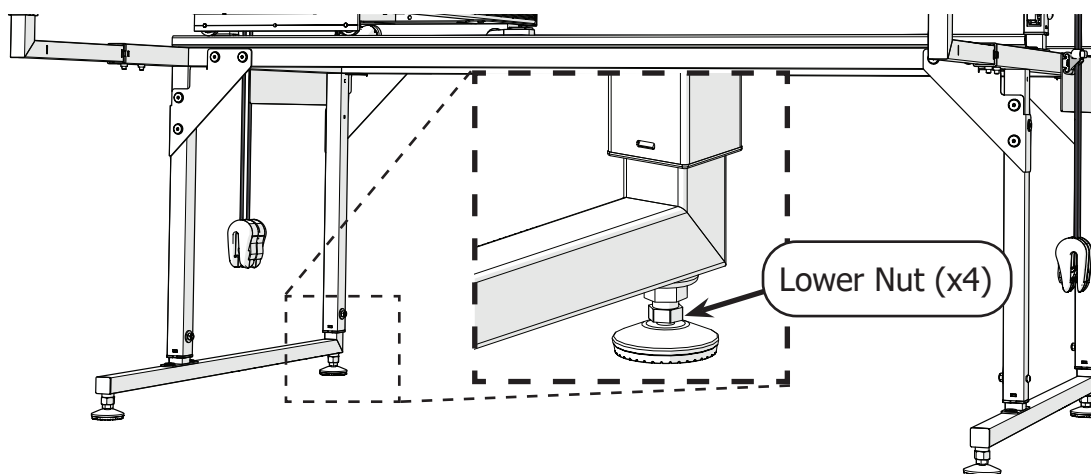

## Task 10 - Level the Frame (Continued)

- 2 With all feet set to the lowest position, it's time to test how level the frame is. Bring the machine to the rear left corner of the frame, and gently release it. If the machine drifts toward any of the feet, that foot may need to be raised. Raise the frame in slow increments by turning the bottom nut on the foot clockwise, and re-test frequently while making adjustments.

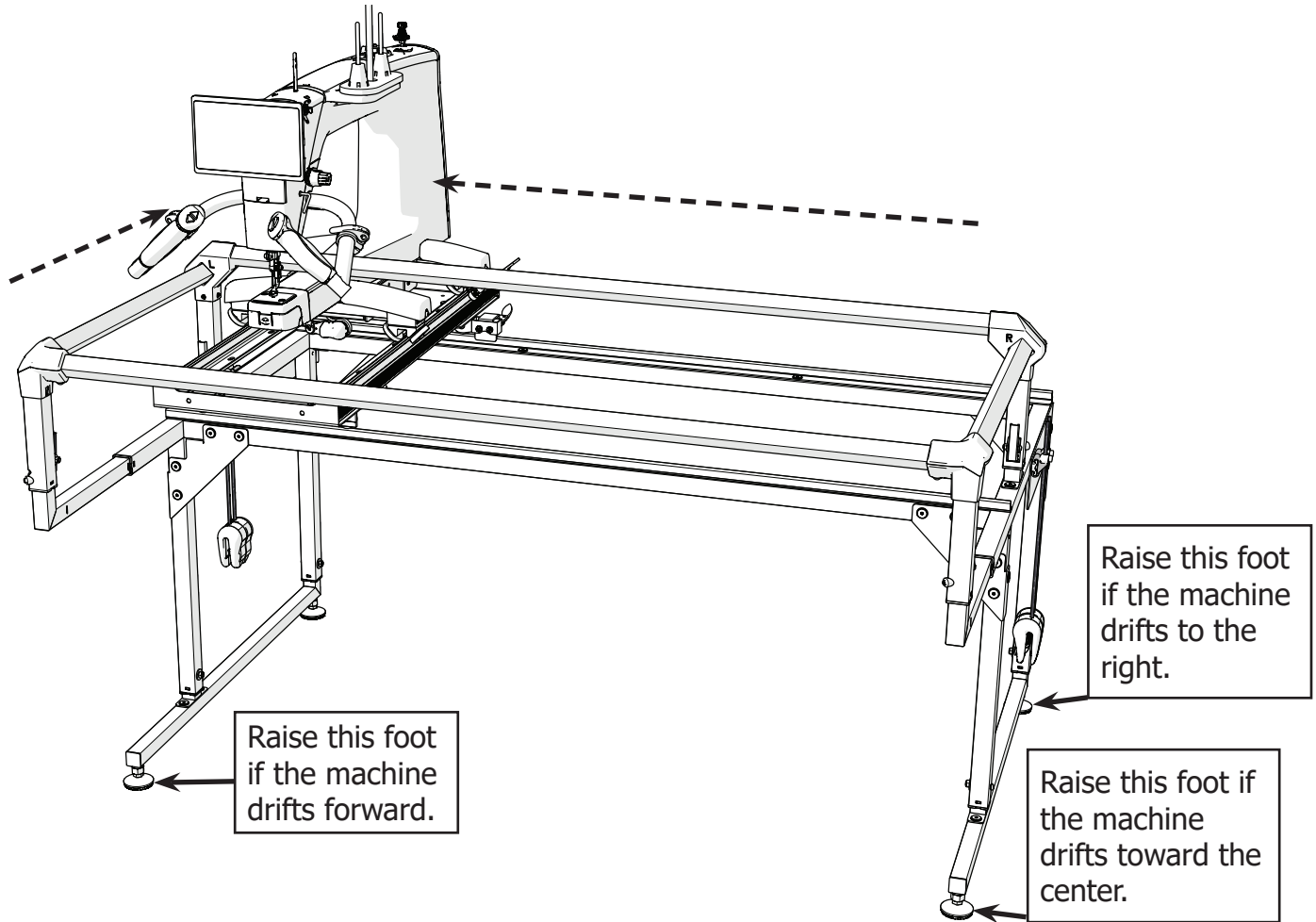

- 3 Test all four corners of the frame, slowly raising any foot that the machine drifts toward until the machine no longer drifts. When satisfied, tighten the top leveling foot nut with the 17 mm Allen wrench on all feet to lock them in place.

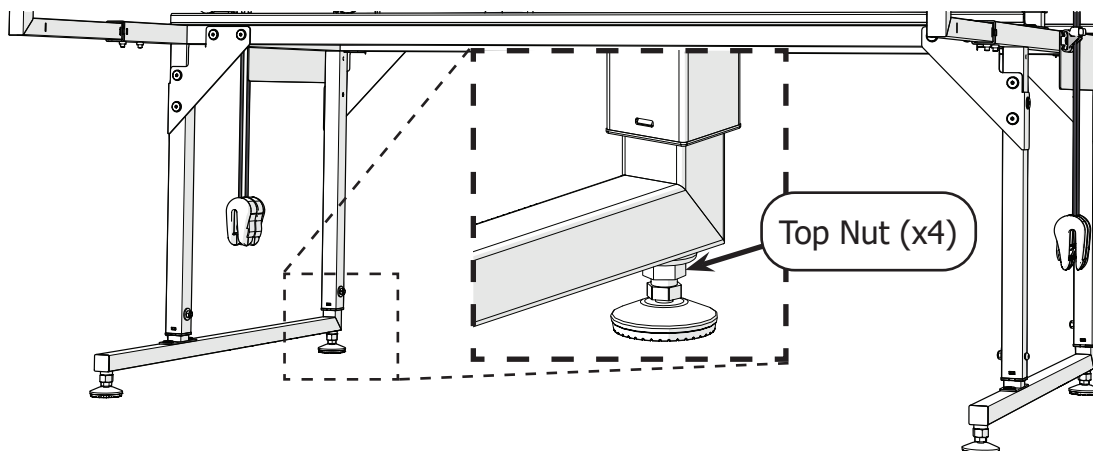

## Task 11 - Fabric Clip Placement

### Parts & Tools Needed:

Back Rail Fabric  
Clip (x3)

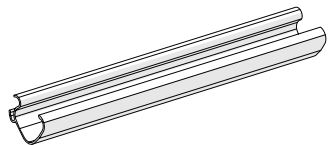

Front  
Fabric Clip (x2)

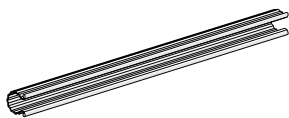

Side  
Fabric Clip (x2)

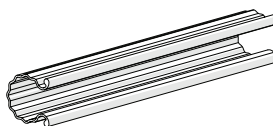

### Instructions

The fabric clips hold and tension the quilt on the frame. The following steps cover how the clips are installed onto the frame:

- 1 The **back rail fabric clips** are installed on the back rail of the hoop. Press them onto the rail from the top, so that the **lip** on the clamps faces the front.

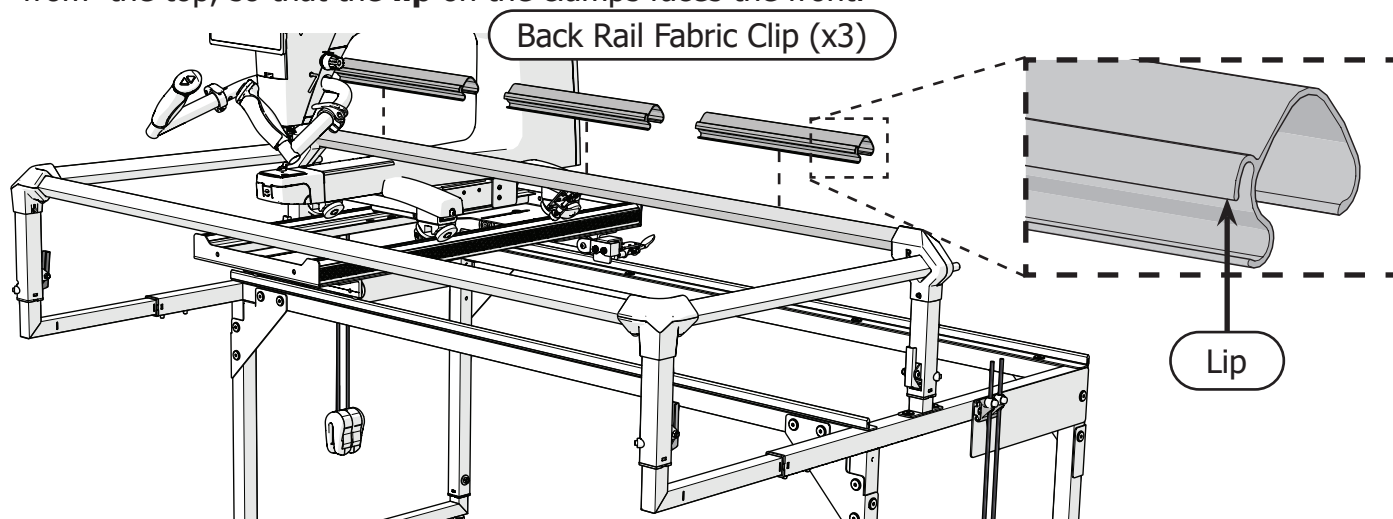

- 2 Press the **front fabric clips** forward onto the front rail.

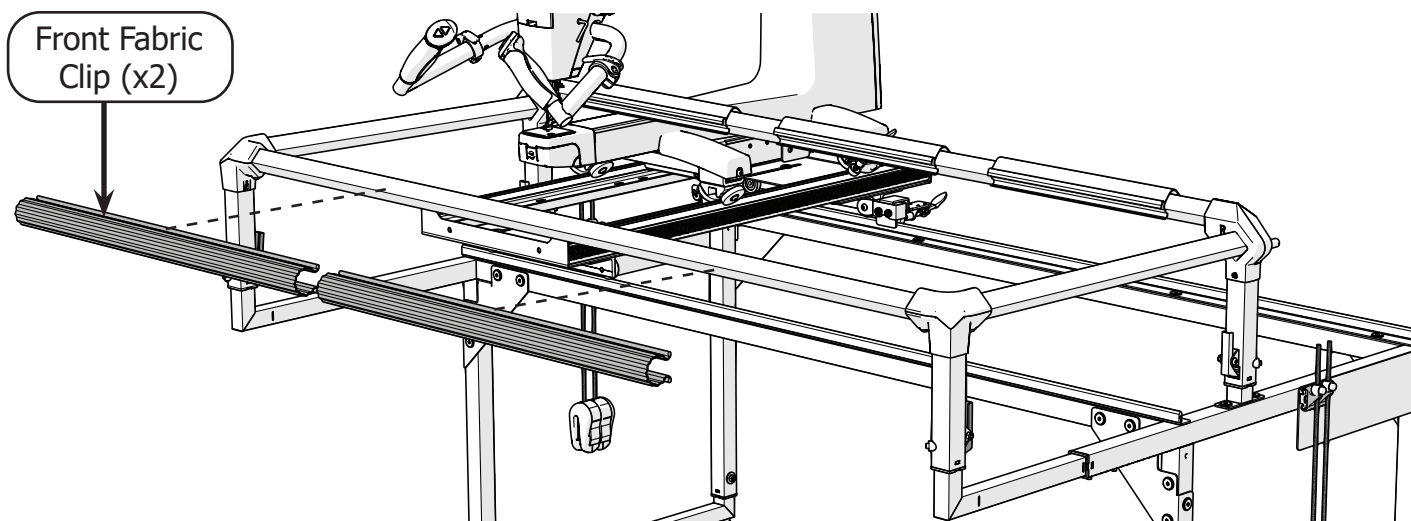

## Task 11 - Fabric Clip Placement (Continued)

- 3 Press the **side fabric clips** onto the side rails from the side of the frame.

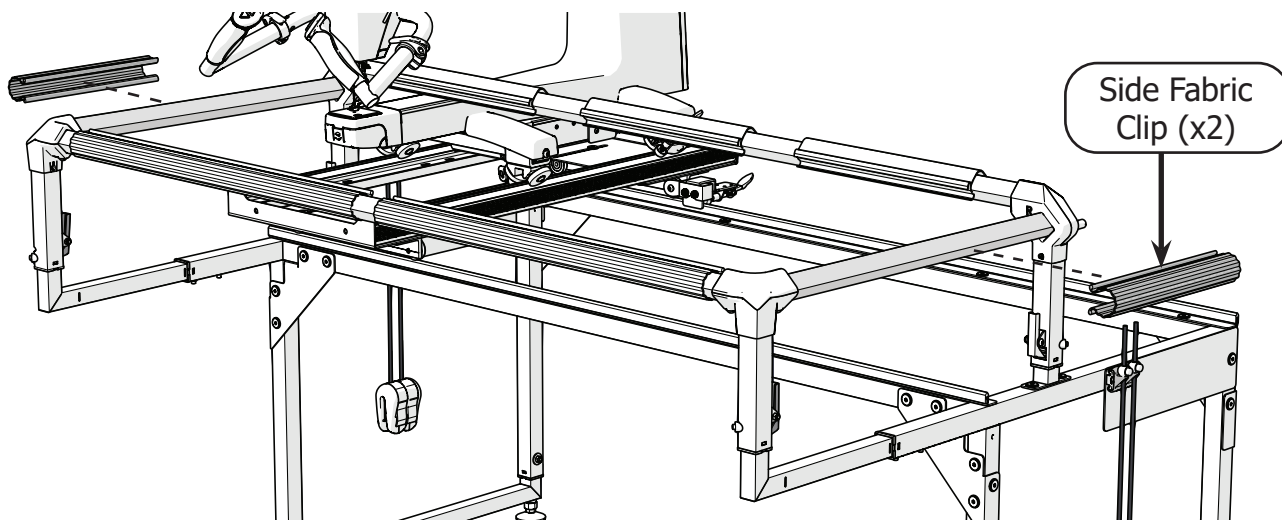

Congratulations! You have completed Part Three of the assembly instructions for your frame. Before continuing to Part Four of these instructions, complete any of the following that apply to you:

- QuiltMotion Part Three.

# Part Four

## **Progress Checkpoint**

Have you:

- Completed Part Three of QuiltMotion (optional)

## Building Your Quilt Sandwich

### Parts & Tools Needed:



Fabric Marking  
Pencil or Chalk

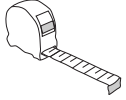

Measuring Tape  
or Ruler



Pins

**Tip:** The fabric dimensions described are ideal for quilts larger than the frame's hoop. Smaller quilts may benefit from different dimensions. See page 48 for details.

### Instructions

The backing and batting help position the quilt top so that it is within reach of the machine on the frame. Take the following steps to cut out the batting and backing, and make a quilt sandwich:

**Right Side/Wrong Side:** Some fabrics have a front side that has a print or other qualities that the back side does not have, or may look washed out on the back. The front of the fabric is called the "right side." The side that looks washed out or doesn't have the print/texture is called the "wrong side."

**Scrim Side:** The scrim side is a structural layer on some types of batting. It often feels coarse or pimpled, while the other side feels smooth or "puffy."

- 1 Cut out backing fabric and batting that is 10" larger than your quilt top.

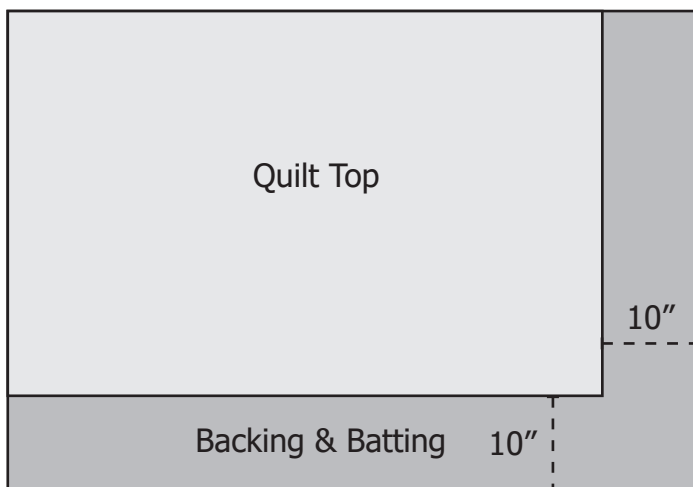

- 2 Fold your **quilt top** in half and mark the **center of the top edge** with a pin or marker.

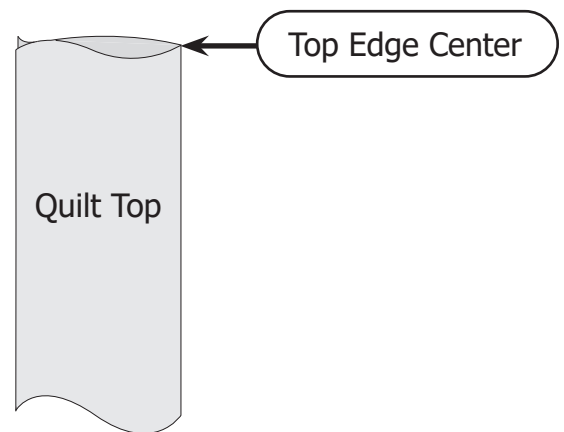

- 3 Fold the **batting** in half and mark the center of the top edge with a pin or marker. Then take a ruler and make a second mark five inches below the first.

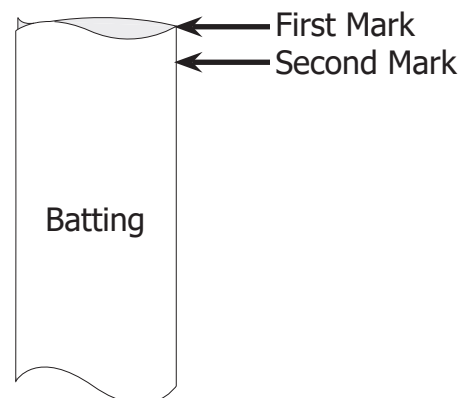

## Building Your Quilt Sandwich (Continued)

- 4 Align the mark you made on your quilt top with the second mark on the batting. **Pin** the two layers together.

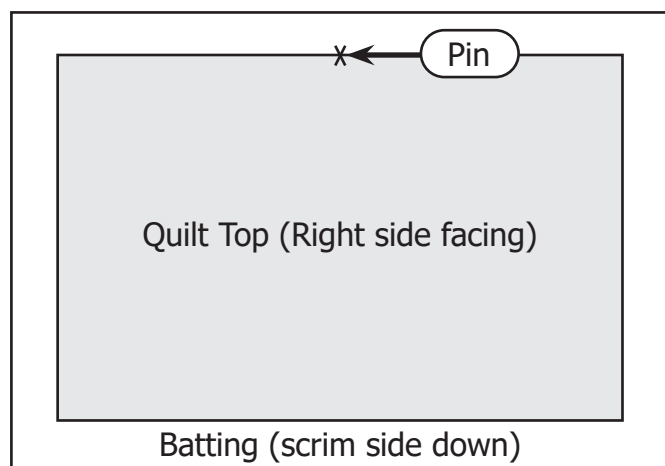

- 5 Lay your quilt **backing** down, wrong side facing up.

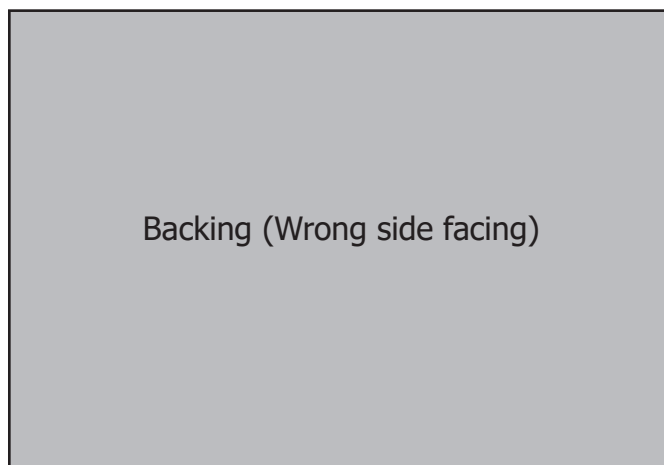

- 6 Lay the batting and quilt top over the backing.

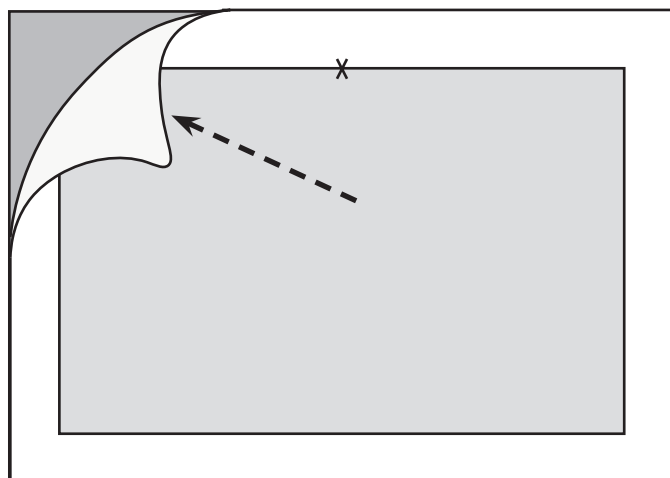

- 7 Pin the layers together to hold your quilt sandwich in place.

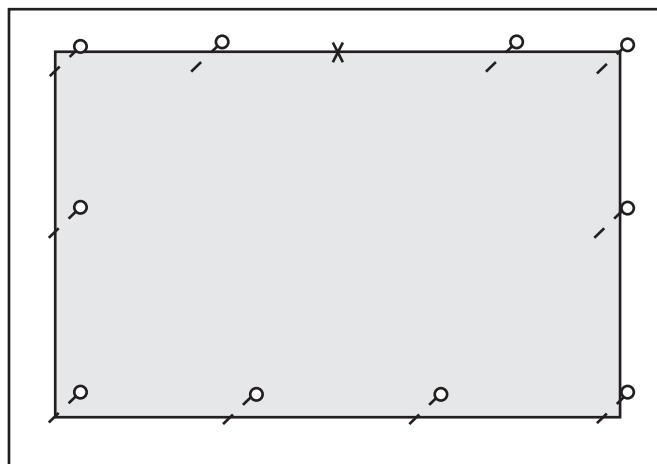

- 8 Roll the quilt up from the bottom so that you can easily carry it to your frame.

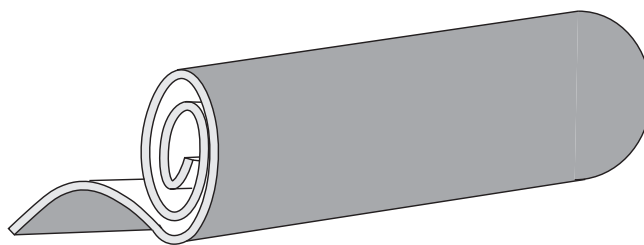
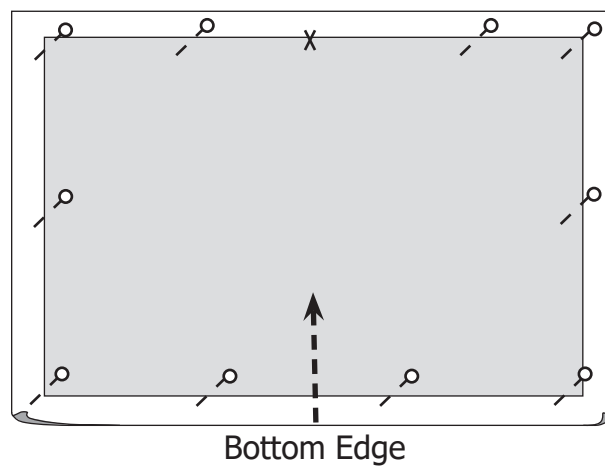

## Positioning the Quilt on the Frame

### Parts & Tools Needed:

Back Rail Fabric  
Clip (x3)

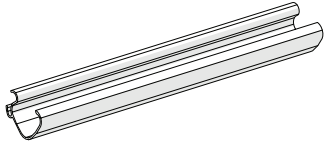

Front  
Fabric Clip (x2)

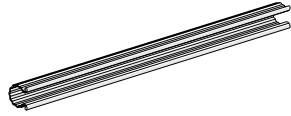

Side  
Fabric Clip (x2)

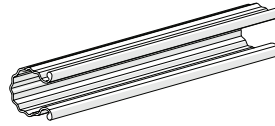

### Instructions

Correct placement of the quilt on the frame ensures the machine will be able to reach the edges of the quilt top, the fabric is well-tensioned, and stitching will be square with the quilt edges. Take the following steps:

- 1 Carry the rolled quilt to your frame. Place the top left corner of your quilt onto your frame.

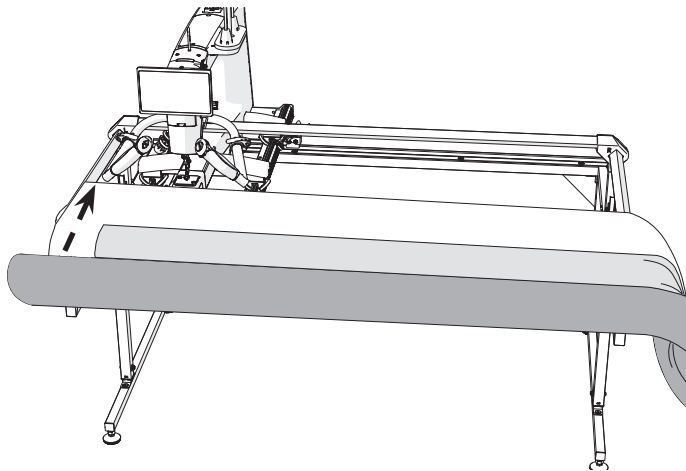

- 2 Tuck the top left corner of the quilt under the machine's **hopping foot**, back to the rear left corner of the frame.

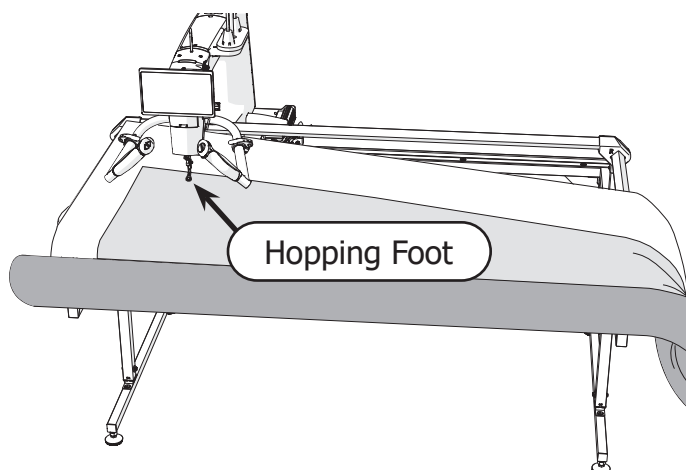

- 3 Square the top edge of the quilt with the back rail, and the left edge of the quilt with the left side rail. Smooth out wrinkles.

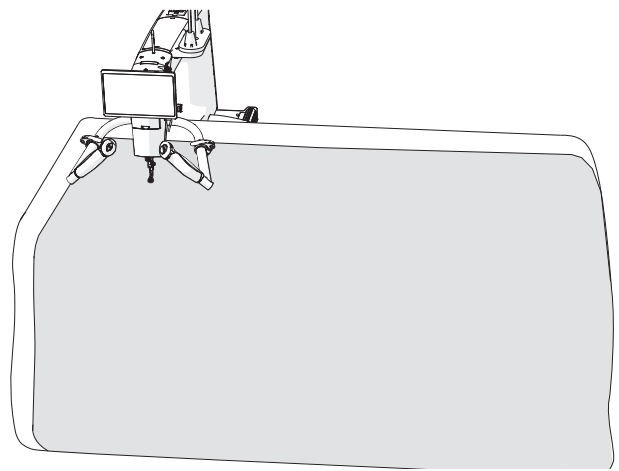

- 4 Push the machine all the way to the back left corner of the frame as far as it will go.

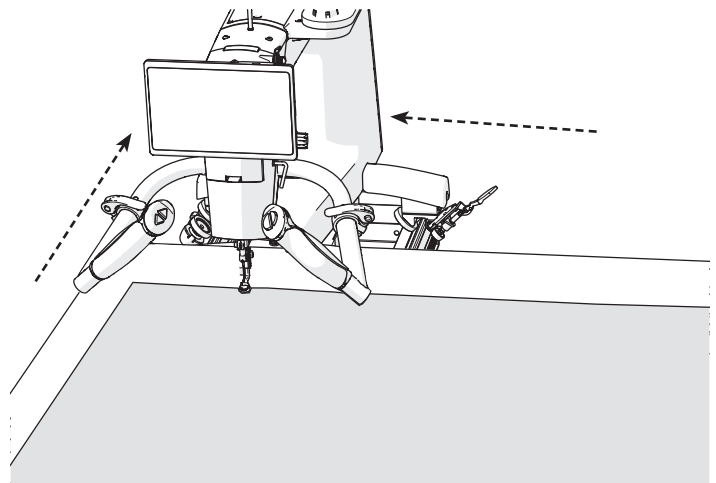



## Positioning the Quilt on the Frame (Continued)

- 5 Adjust the quilt so the hopping foot can reach the corner edge of the quilt top. The left edge of the quilt may not reach all the way to the side rail.

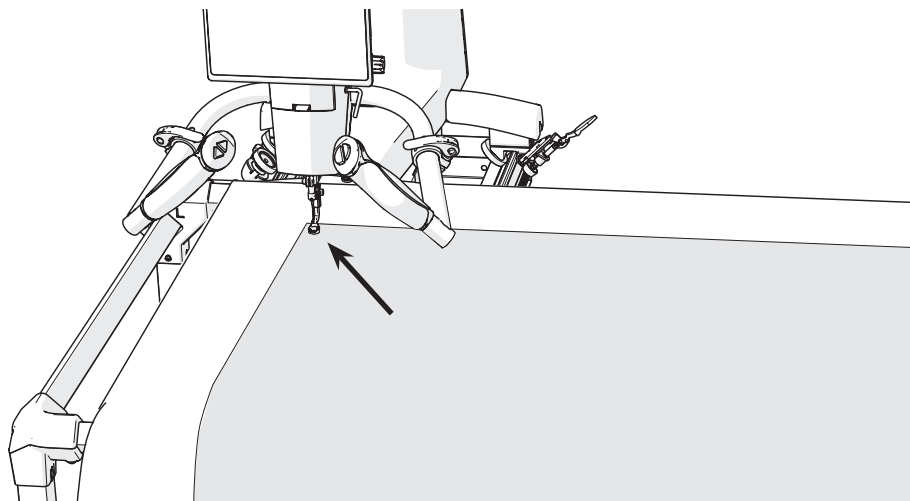

- 6 Press the back clamps over the fabric on the back rail, being careful to keep the fabric square and wrinkle-free. The **lip** of the clamp should face the front of the frame.

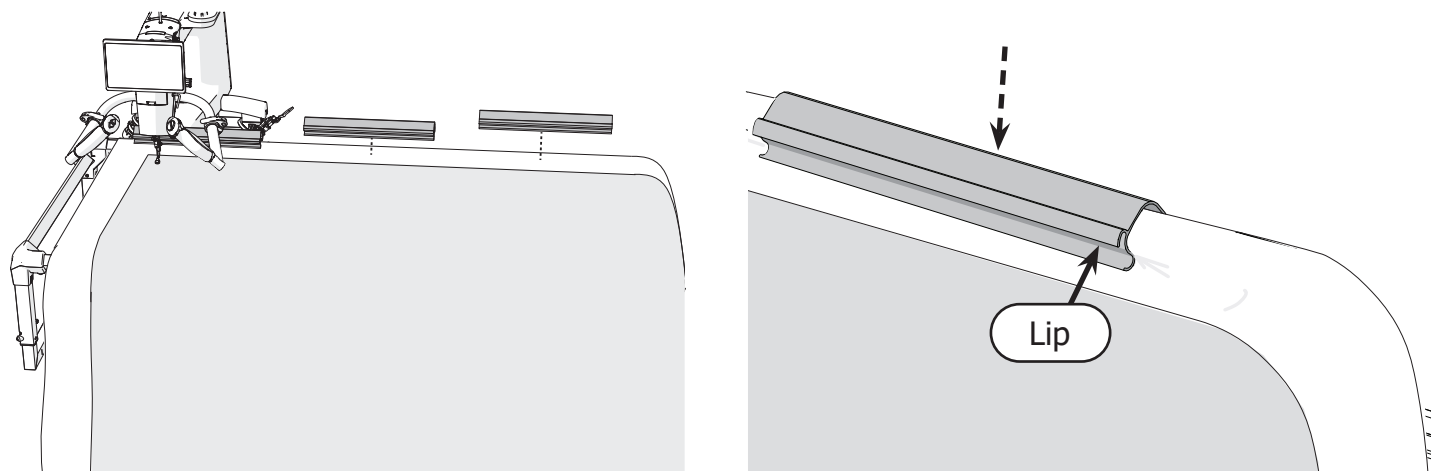

- 7 Attach the front fabric clips to the front rail. Smooth out any wrinkles in the fabric layers.

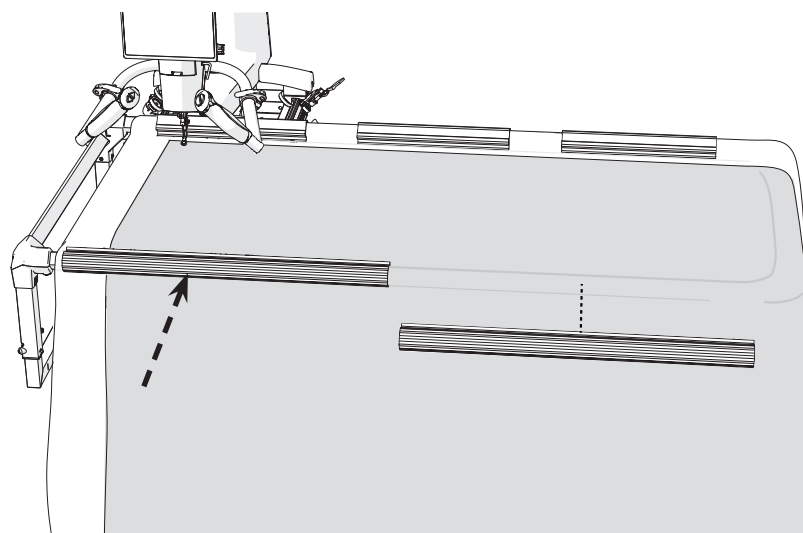

## Positioning the Quilt on the Frame (Continued)

- 8 Press the side clamps on over the fabric on the side rails. Do not install the fabric clip if the fabric doesn't reach the side rail.

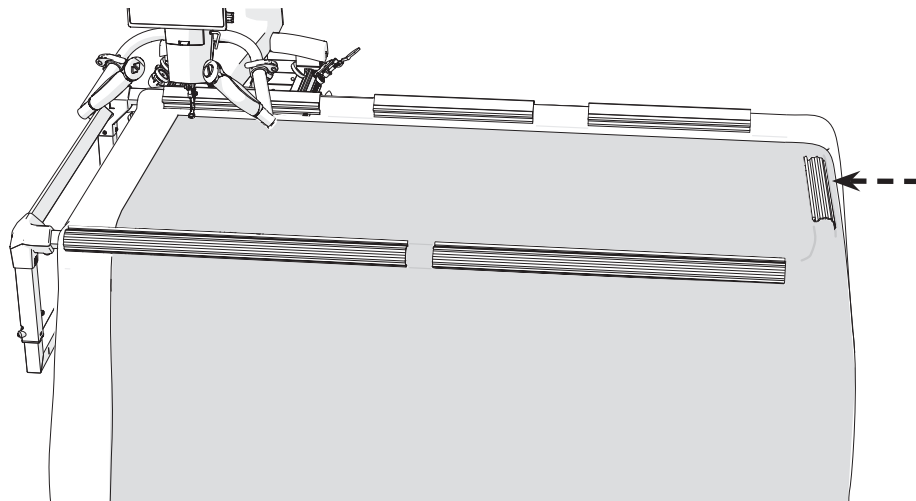

- 9 Roll excess fabric from the top edge of your quilt to the rail. Wrap the fabric straps around the rolled fabric and clip them into the lip on the fabric clamps.

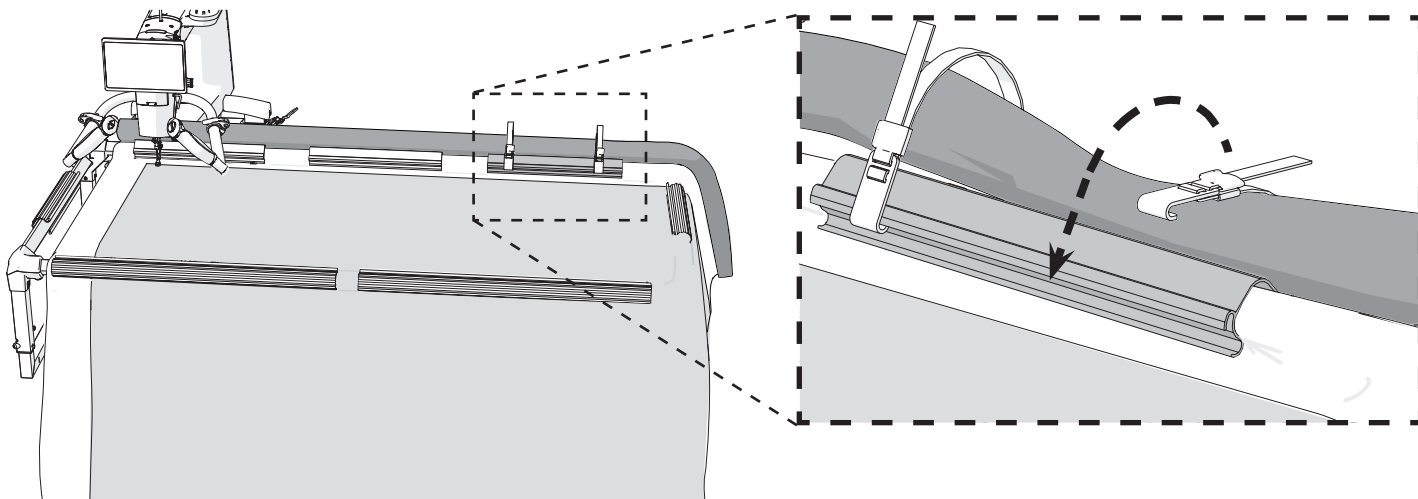

- 10 Tighten the fabric roll in place by pulling on the straps.

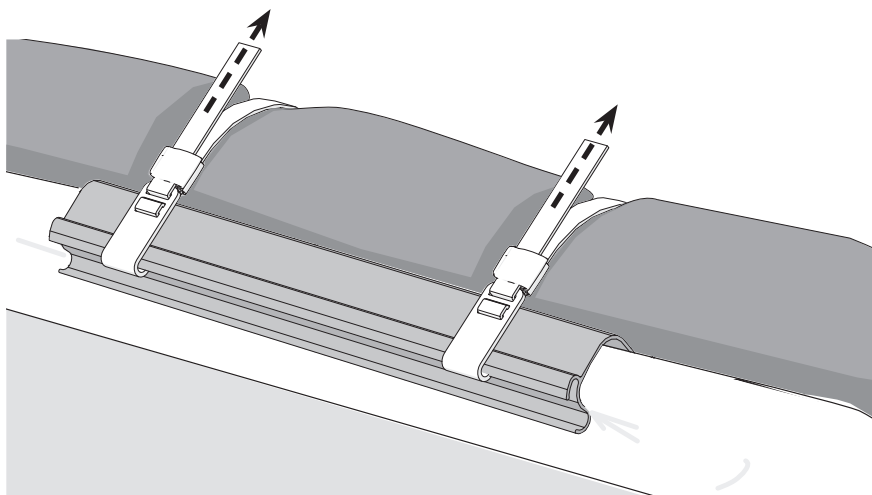

## Using the Bungees

### Parts & Tools Needed:

Side  
Fabric Clip

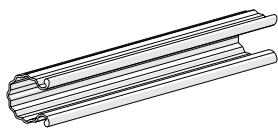

Bungee  
Mount (x4)



Bungee  
Clamps (4 pack)



### Instructions

Sometimes one edge of the fabric won't reach the side rails of the hoop, and you will need to use the bungees to attach and tension the fabric. Take the following steps to install and use the bungees:

- 1 Press the side fabric clip onto the side rail from the bottom.

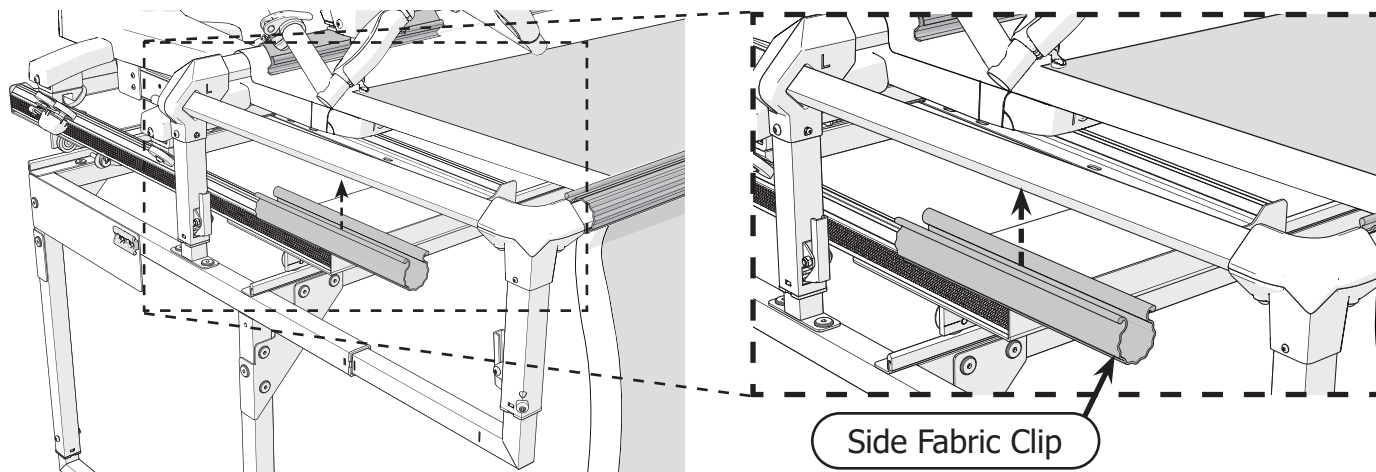

- 2 Pinch the clamp opening together and slide two bungee mounts onto the clamp.

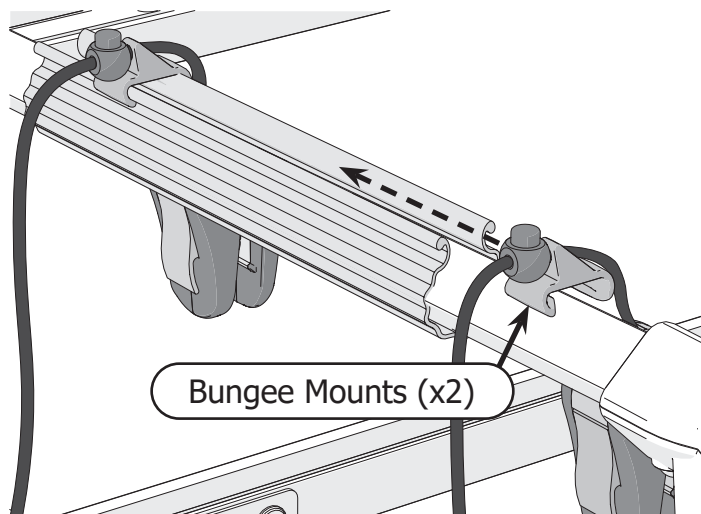

## Using the Bungees (Continued)

- 3 Slide the edge of the quilt into the throat of the clamps. Make sure the tooth digs into fabric, not batting.

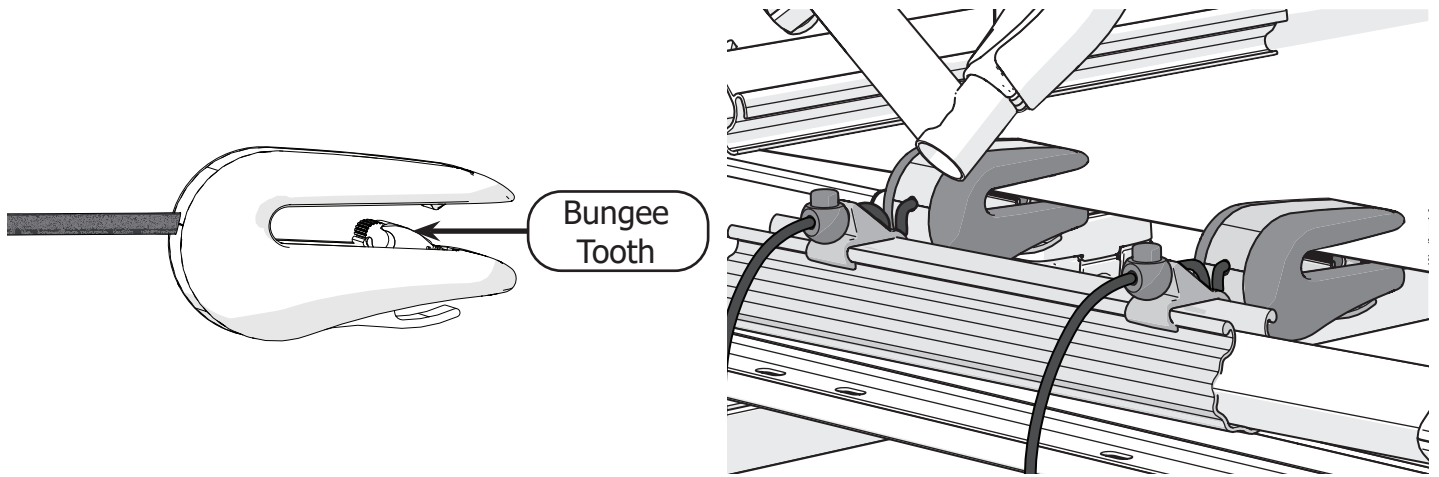

- 4 Press down on the bungee stops and pull the cord tight so the fabric is straight and smooth.

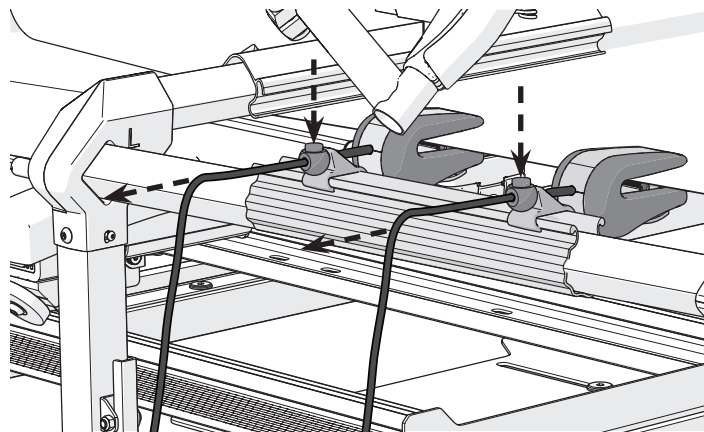

- 5 **Result:** the machine is able to reach the edge of the quilt top. The fabric is held tightly and smoothly.

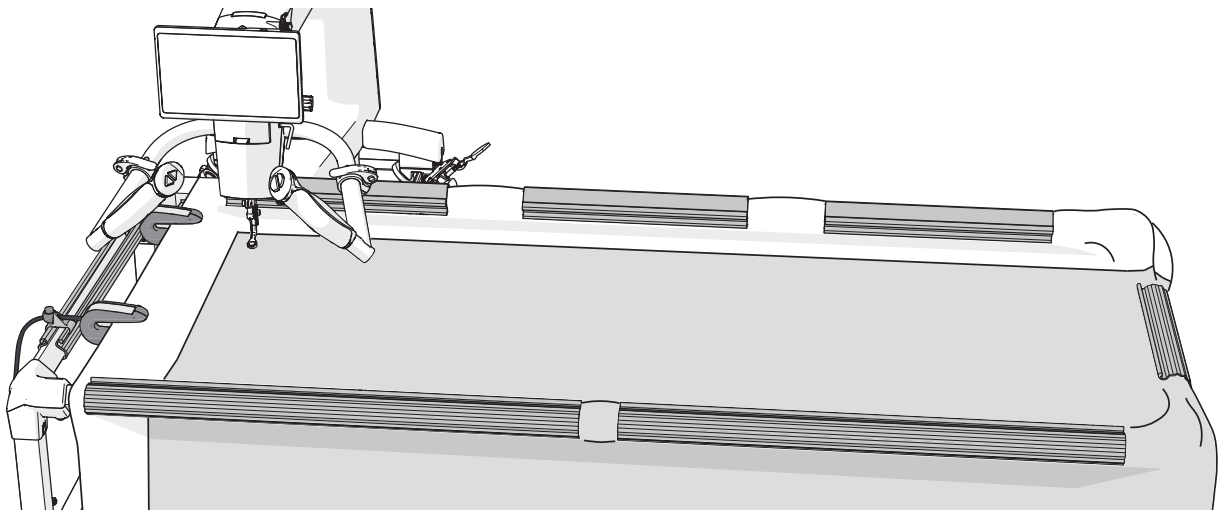

## Tacking Down Your Quilt

Tack down the edges and sides of the quilt about a quarter of an inch from the backing and batting.

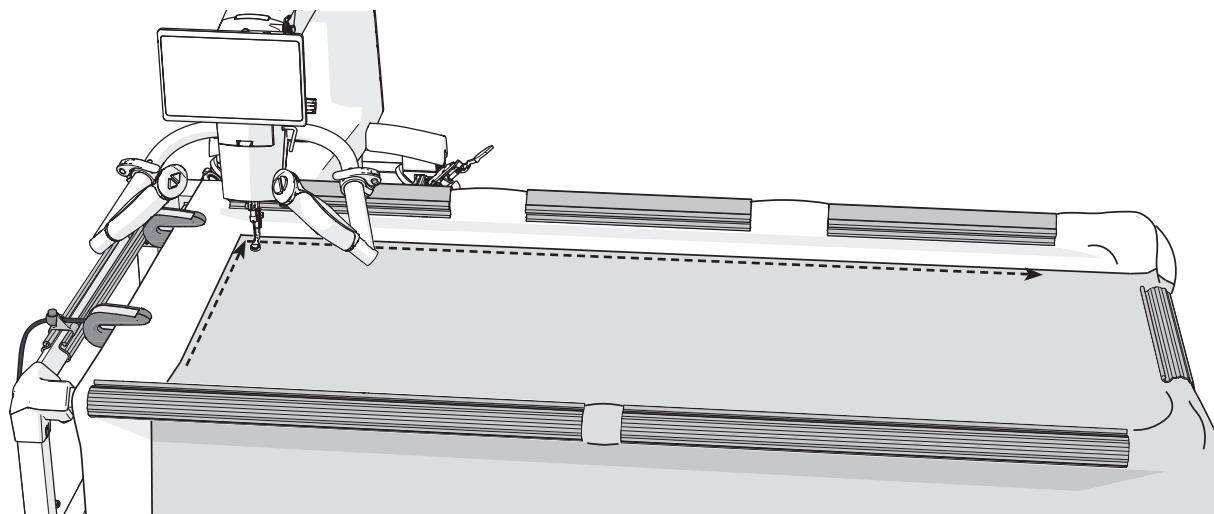

Note: When you move to a new zone, don't forget to tack down the edge of the quilt top first thing. This prevents the edges of the quilt creeping inward as you lay down stitches toward the center.

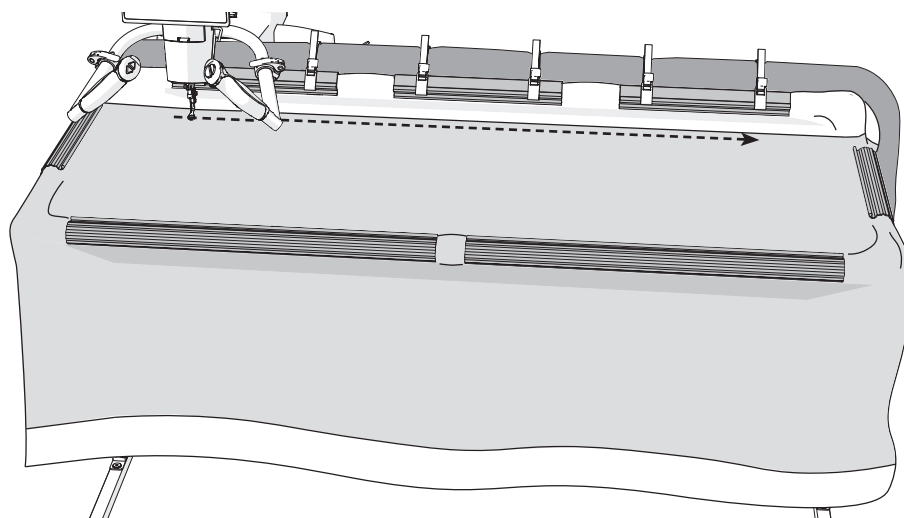

## Moving Your Fabric

### Instructions:

Once you've finished quilting the available space (called a zone) on your quilt, you will need to move your quilt in the hoop to a new zone.

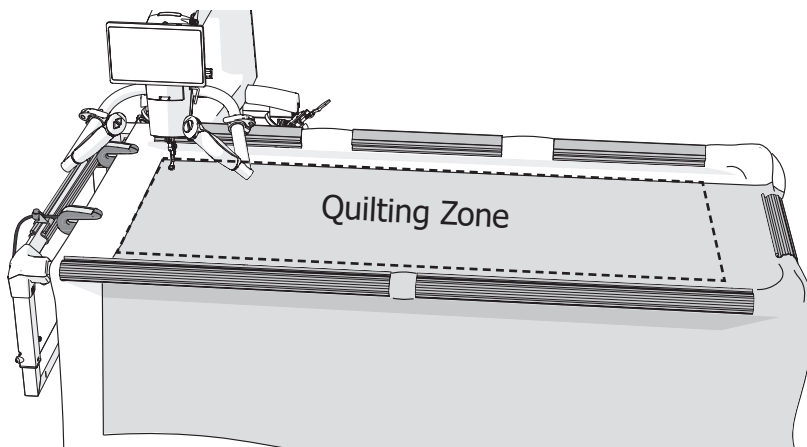

- 1 Remove the fabric straps from the back rail fabric clips, and remove any bungee clamps by pressing the **clamp release**.

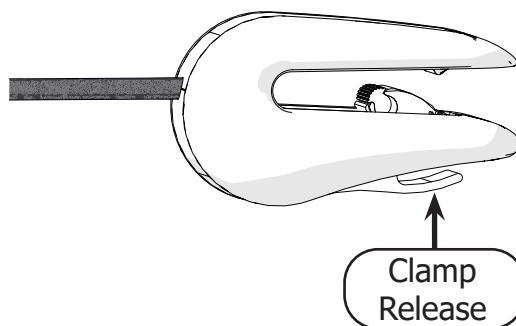
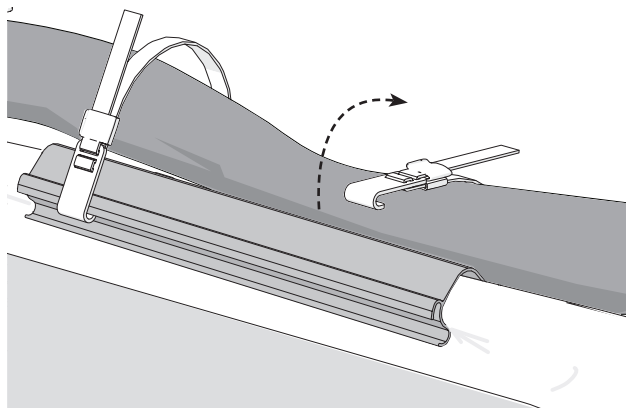

- 2 Remove any bungee mounts that are installed, and then pull off the fabric clips.

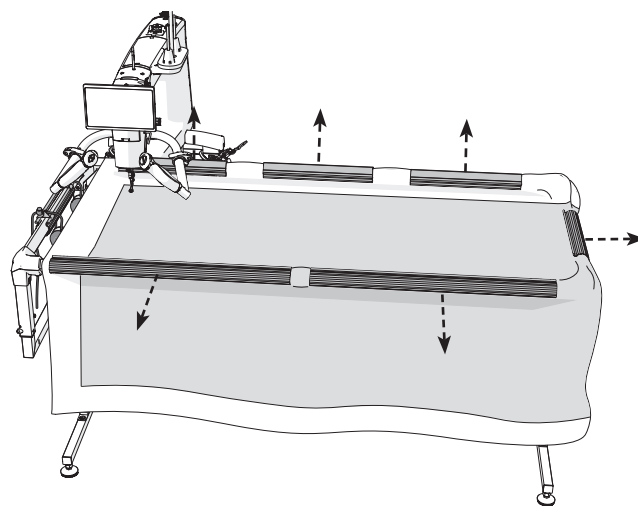
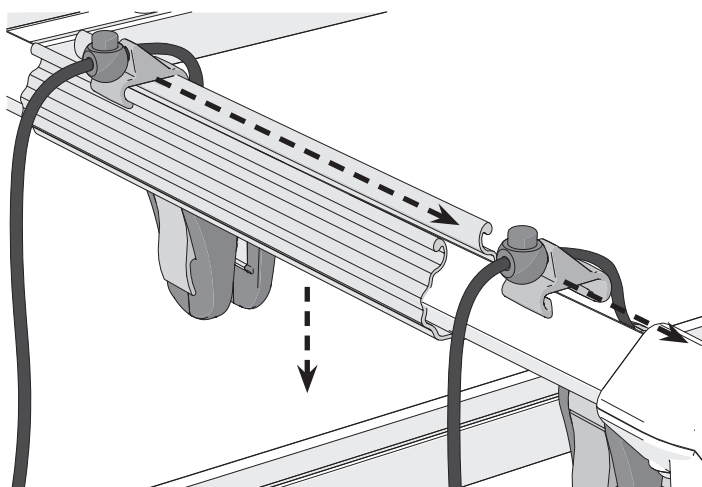

## Moving Your Fabric (Continued)

- 3 Position the quilt so that the next zone is within the reach of the sewing machine. We recommend going from left to right across the top of the quilt, then working downward from left to right, like reading a book.

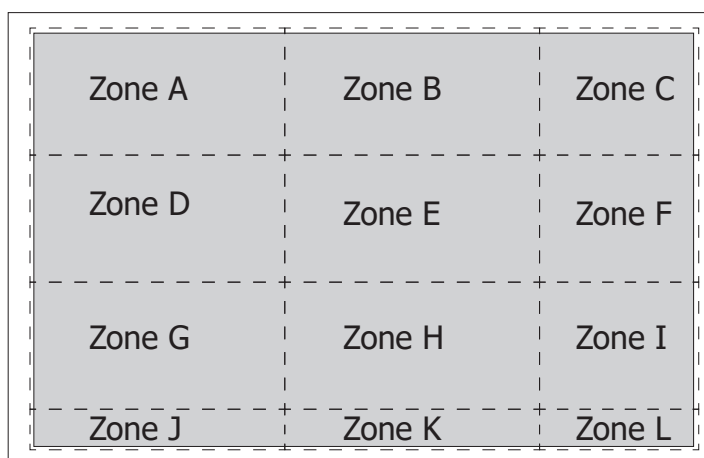

- 4 Secure the quilt with the clamps, straps, and bungees (if needed).

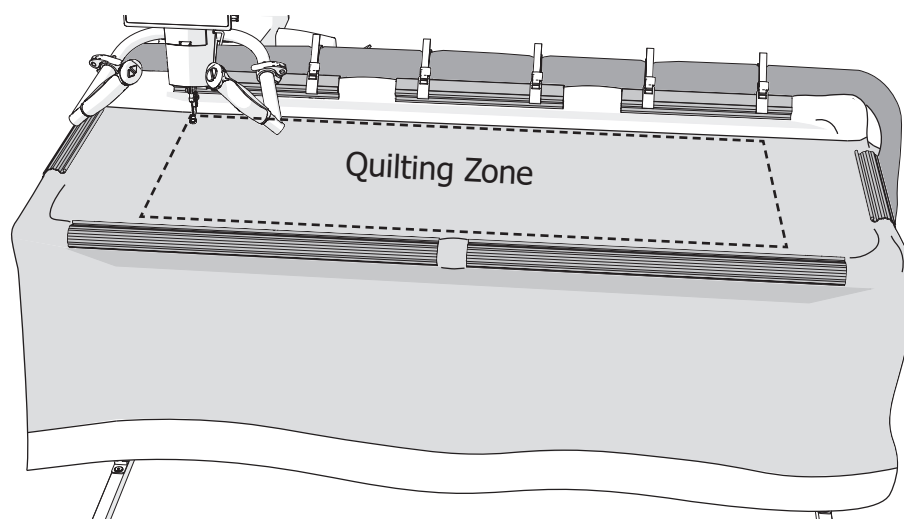

- 5 Tack down the edges of the quilt top that you now have access to. Place your stitches about a quarter inch from the backing and batting.

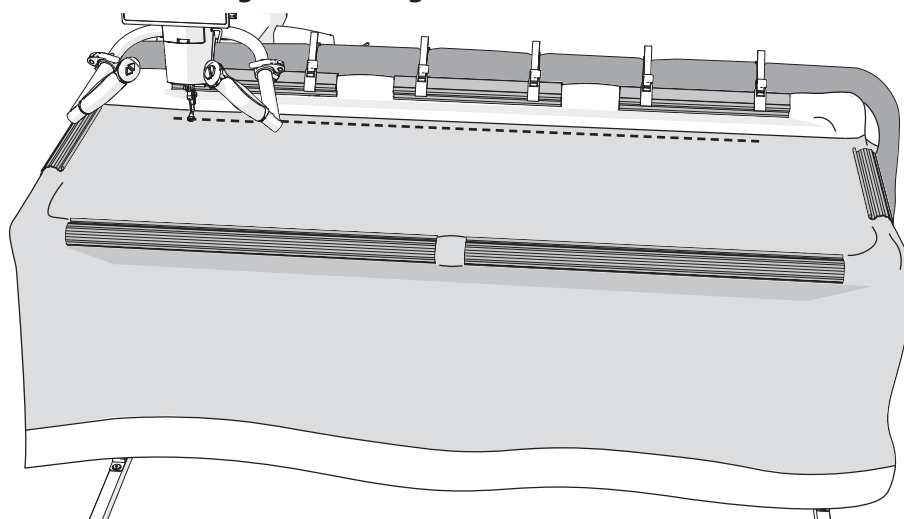

## Using the Channel Locks

### Instructions

The channel locks restrict the movement of the bottom carriage and the sewing machine or top plate so that you can easily stitch a straight line.

- To quilt a straight line horizontally across the frame, close the channel lock on the machine.

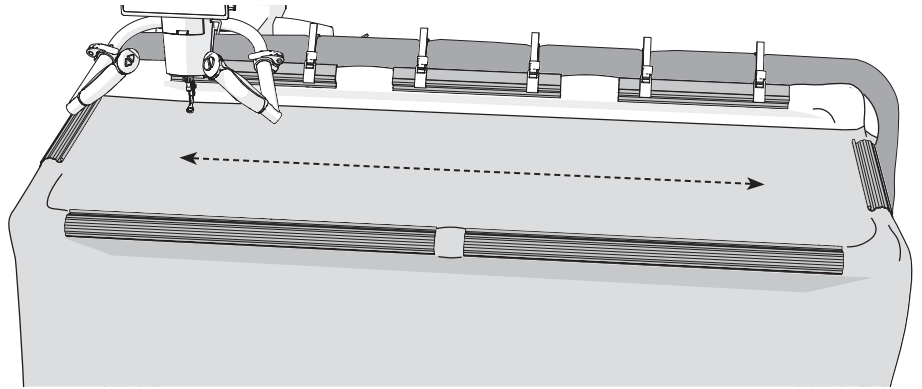
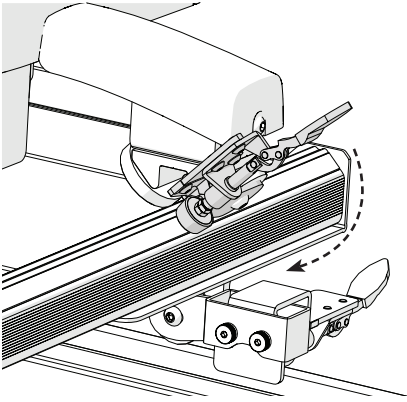

- To quilt a straight line from the front-to-back of your frame, close the channel lock on the bottom carriage.

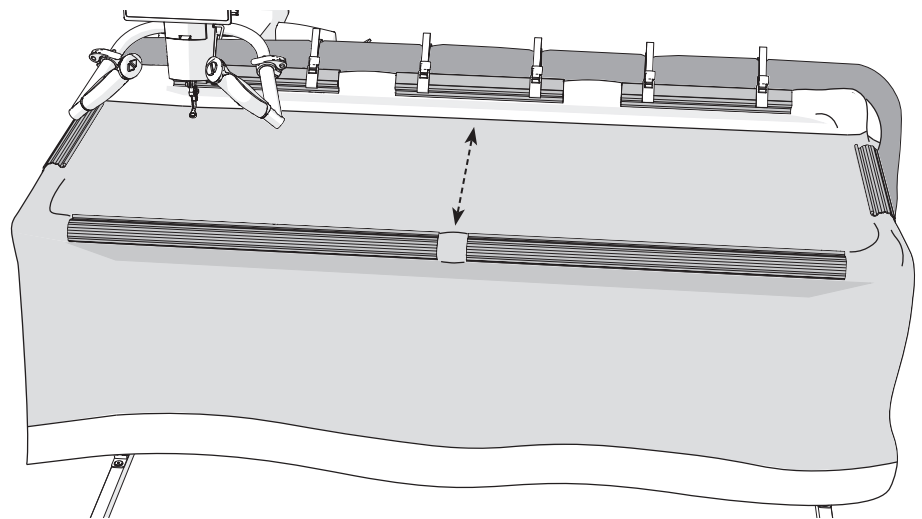
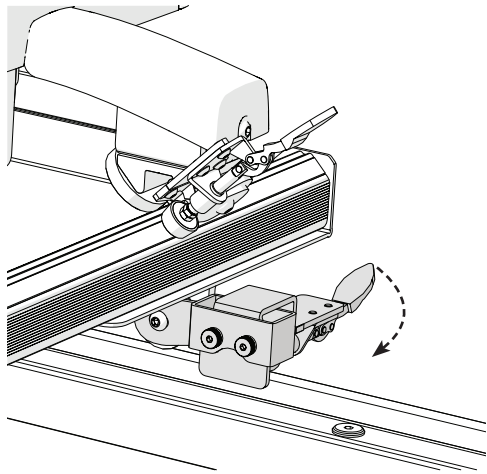

Congratulations! You have completed the assembly instructions for your frame. If you're using a quilting machine, check out part four of your quilting machine manual.



## Quilts of Alternative Size and Shape

### Parts & Tools Needed:

Read these steps all the way through first to avoid making a mistake when cutting your backing and batting.

If your quilt top doesn't reach the rails, you will need to cut your quilt backing to be large enough to make up the difference.

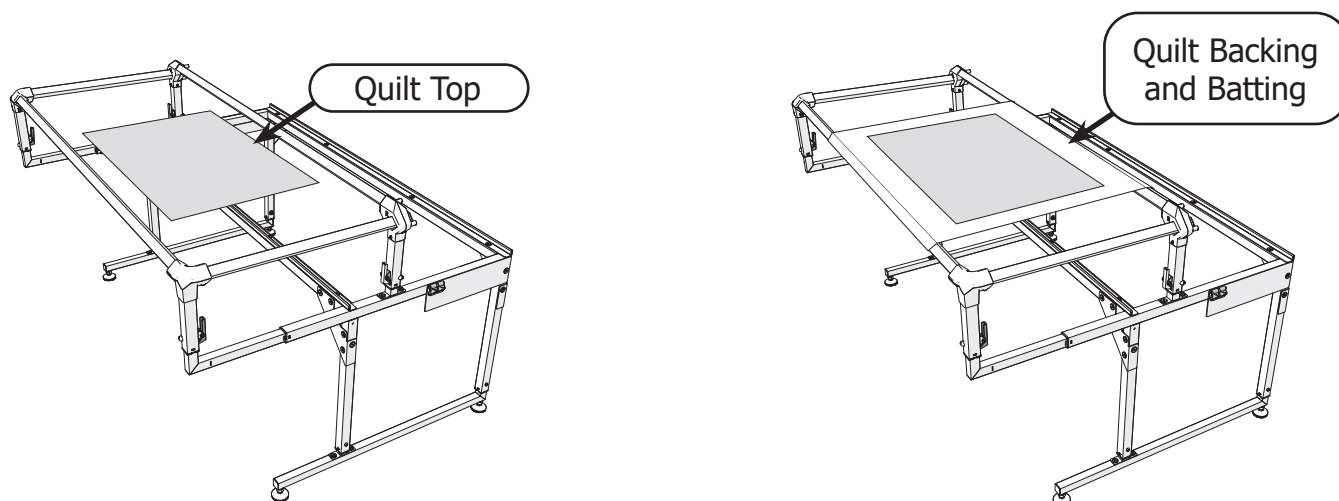

Measure the depth of your frame hoop and add 10" to get the minimum depth of your quilt back.

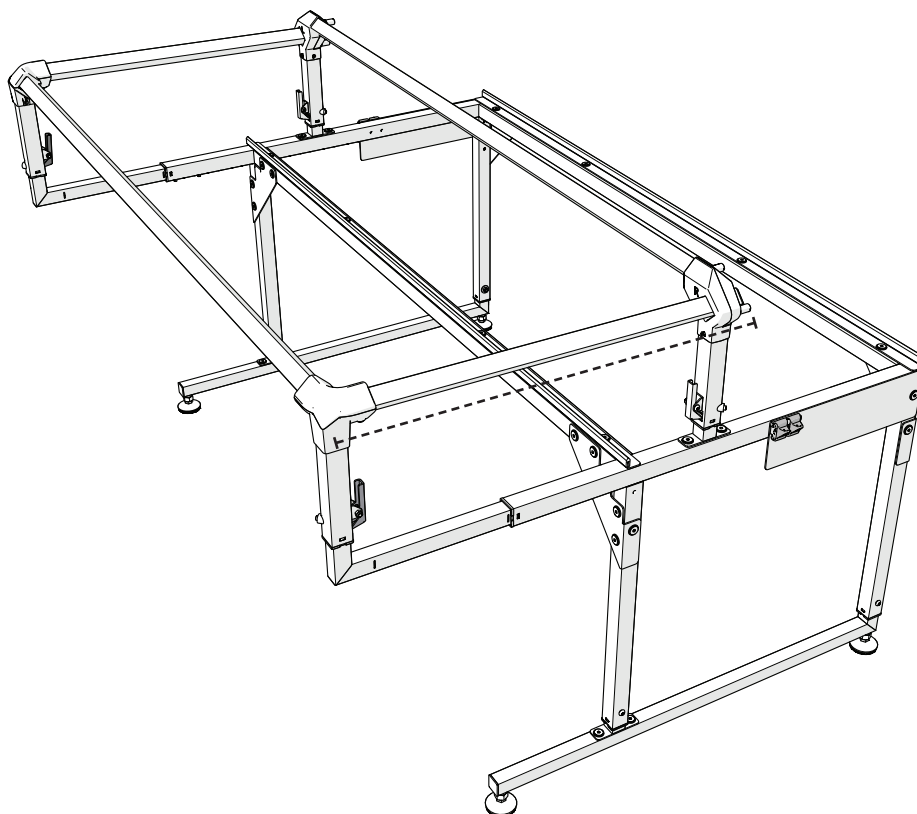

## Quilts of Alternative Size and Shape (Continued)

If your quilt top doesn't reach the side rails, there are two options:

- You can cut the backing to be wide enough to cross the full width of the frame and be clamped into place (65" wide).
- You can cut the backing to be 6-8" longer than your quilt top so that the bungees can grasp the sides of the quilt, but won't get in the way while you sew.

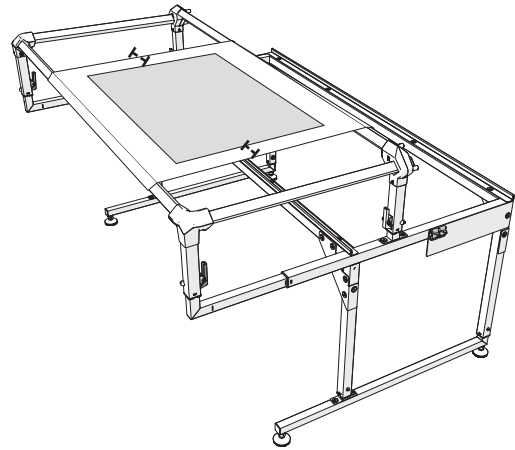
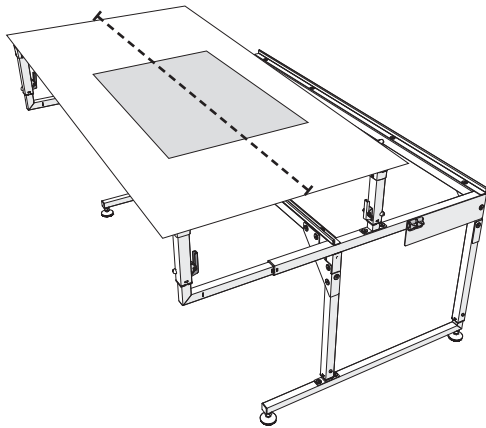

The stroke of the machine is another thing to consider when cutting your backing. Push your machine to the back-left corner of your frame. Notice that the needle doesn't reach all the way to the corner.

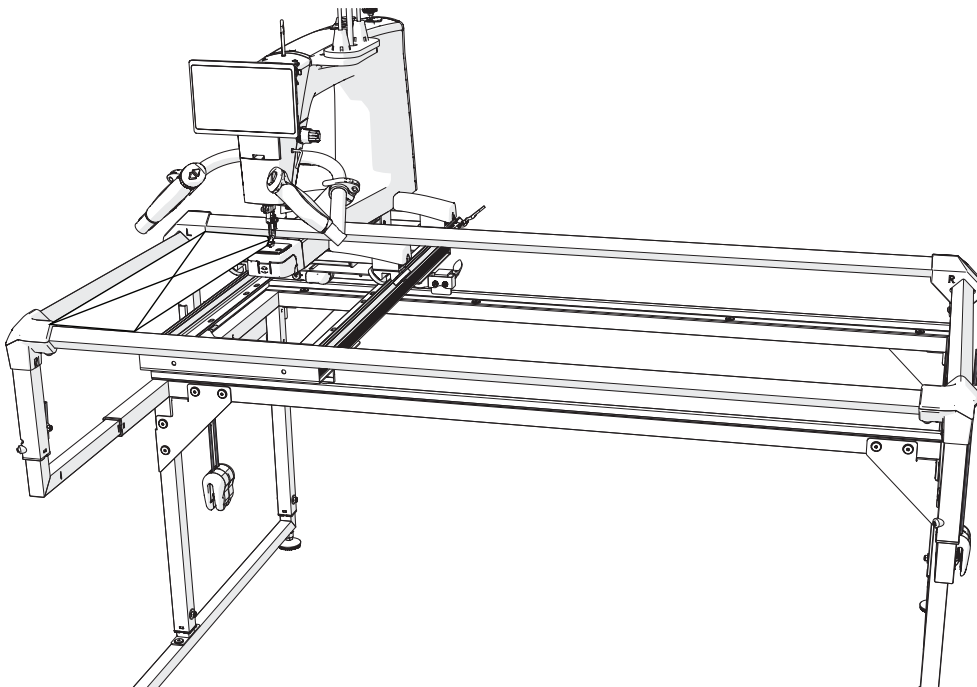

## Quilts of Alternative Size and Shape (Continued)

Move your machine to the front-right corner of the frame and you'll find the same thing. There is an area around the circumference of your frame where your machine will not be able to reach.

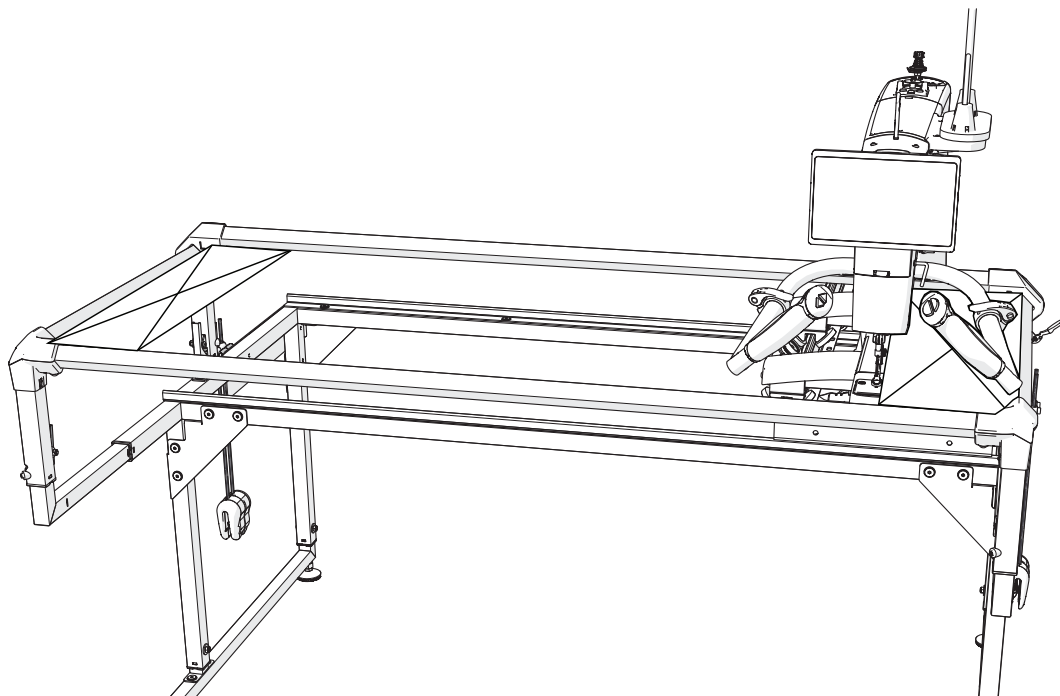

If any part of your quilt top ends up in the areas the machine can't reach, you won't be able to sew that part of your quilt top. Cutting the backing extra large will allow you to keep the quilt top in the quiltable area of the frame.

## Getting Started

### Instructions:

Once you've attached your quilt to your frame and basted down the quilt top edges for the first quilting zone, here are some helpful things to consider.

1. Over time your quilting frame may settle into a slope. If you find the machine drifts or pulls to the side, you may need to re-level the frame.
2. Keep a record of your quilt measurements. This will help when placing patterns later on.
3. Keep your quilting area clean, and wipe down your frame and carriage tracks as well as the machine and carriage wheels frequently.
4. Prepare a small test quilt that you can stitch on between bobbin changes to set your tension. This is also a great way to practice a pattern before stitching it into your quilt. The test quilt should be made of the same materials as your actual quilt, otherwise it will not work for setting tension.
5. Pull up the bobbin thread at the start of a new session of stitching, and also at the end. This will prevent the bottom thread tail from getting sewn down on the bottom of the quilt.

To pull up bobbin thread at the start of stitching:

- a First, position the needle directly above where you want to begin your pattern.
- b Pull on the **top thread** so that it is tight and jog the needle up and down using the single stitch button on the display.

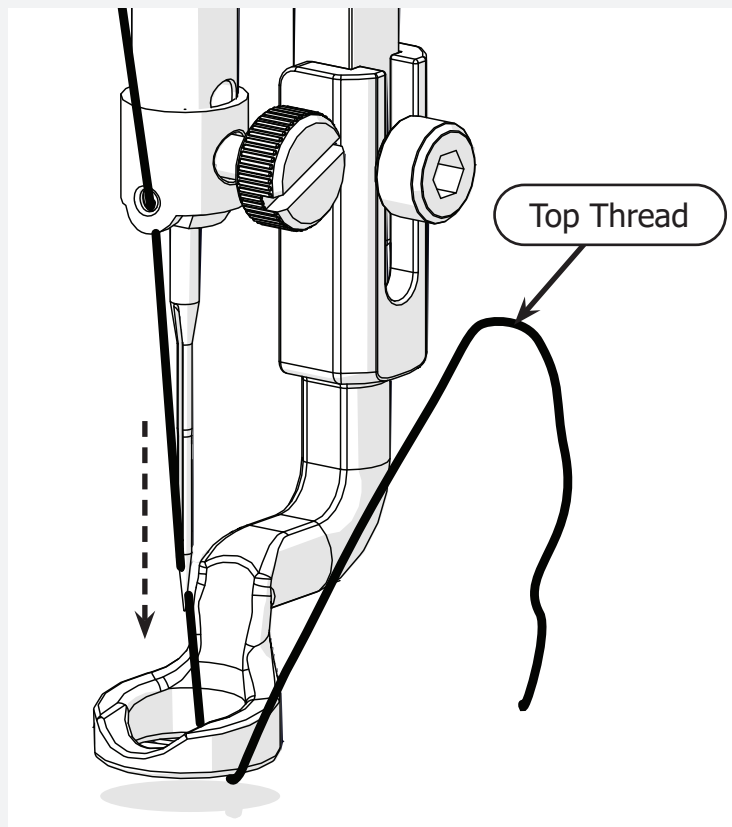

- c While still tightly holding the top thread, move the machine several inches to the side. Your top thread should pull a loop of **bobbin thread** through the **start point** to the top of the fabric.

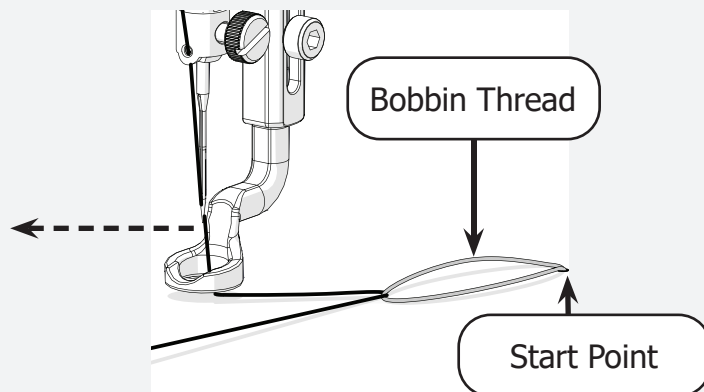

- d Pull on the loop of **bobbin thread** until the loose end of the thread comes up from underneath the fabric.

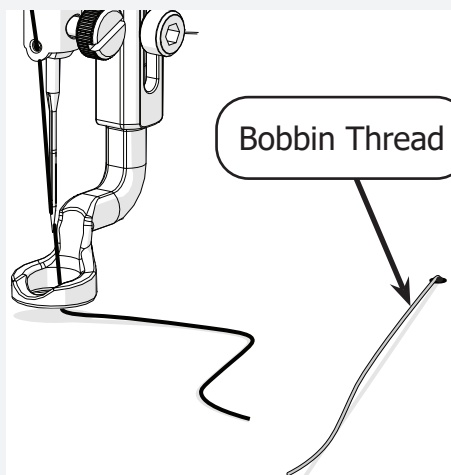

- e Pull on the bobbin thread while moving the machine back to the start point. This makes sure that there is no loose thread underneath the fabric.

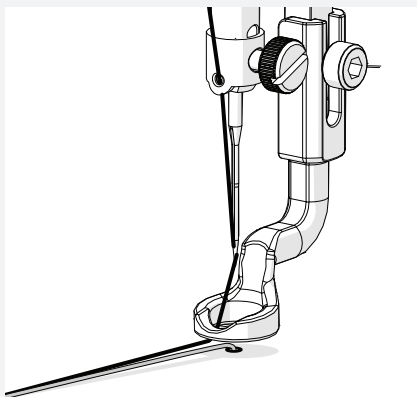

- f Begin stitching.

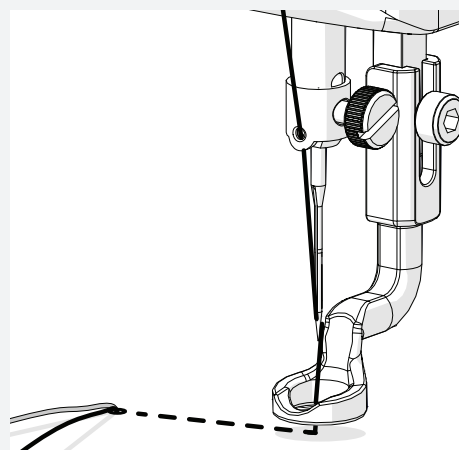

To pull up bobbin thread at the end of stitching:

- a Move the machine away from the tie-off stitch.

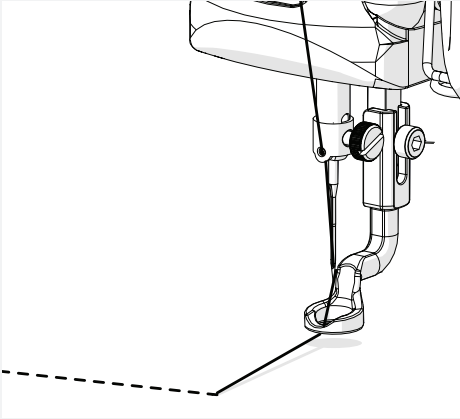

- b Hold the thread to make a loop and return the machine to the tie-off stitch.

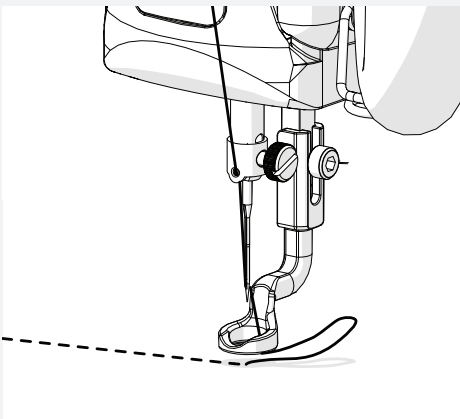

- c Make a single stitch over the tie-off.

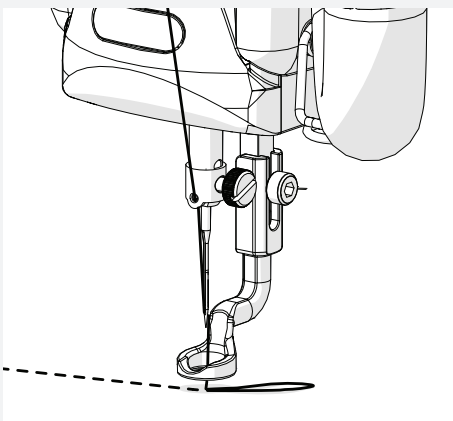

- d Hold the loop and move the machine away from the tie-off again.

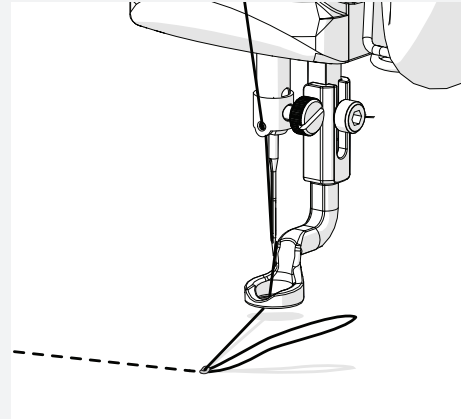

- e Keep moving away from the tie-off until a loop of bobbin thread is pulled up above the fabric. Cut all threads close to the tie-off.

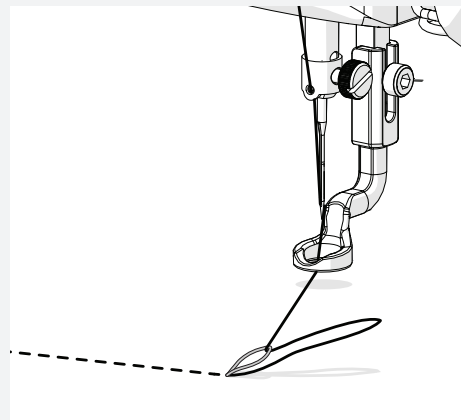

---

**The Grace Company**  
**Phone: 1-800-264-0644**  
**[www.graceframe.com](http://www.graceframe.com)**

