

# Q'nique21 **PRO**

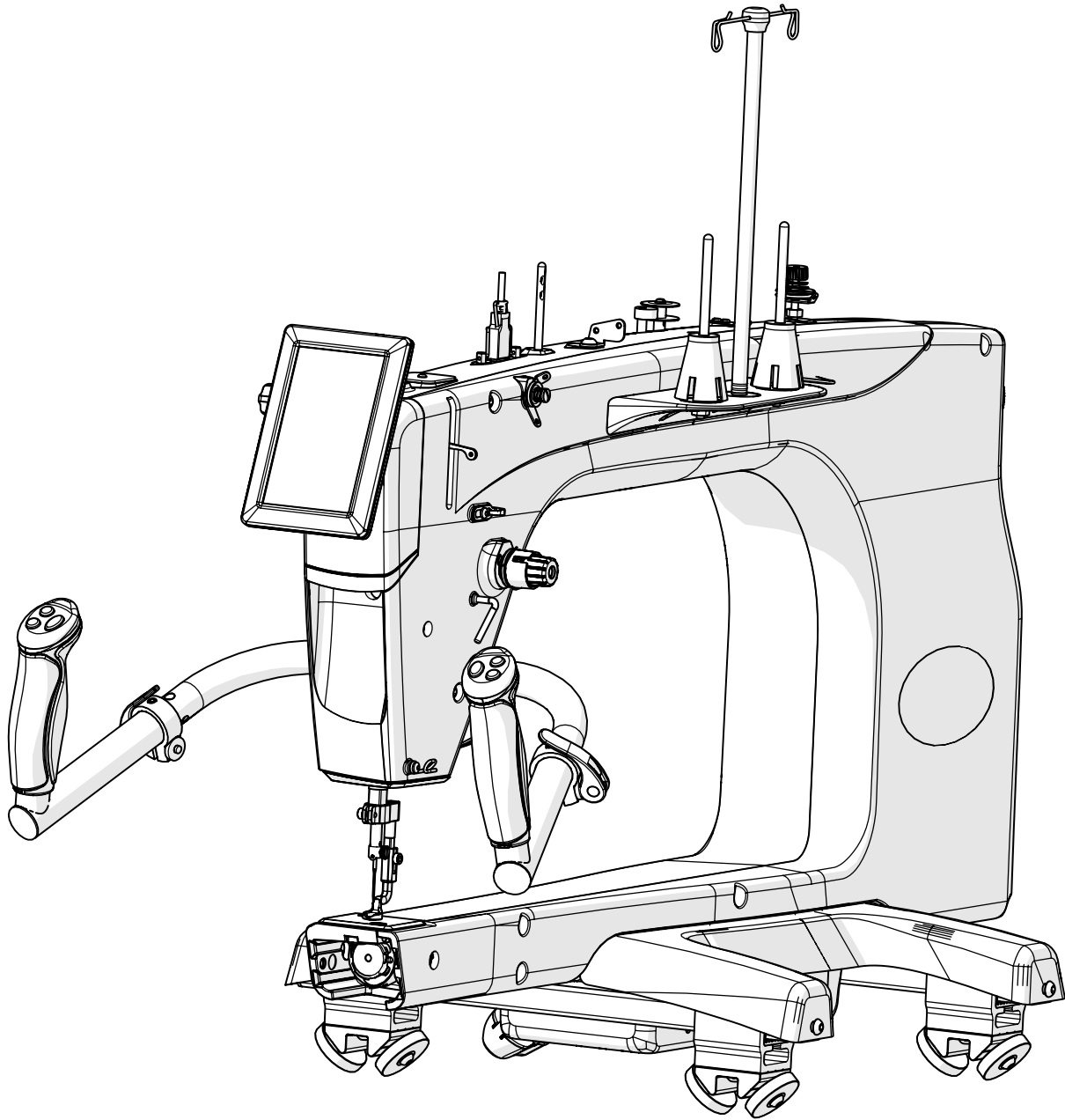

Copyright May 25, 2021  
Grace Company  
(Reproduction Prohibited)  
Version 4.1

MADE BY  
*Grace*

# Important Safety Instructions

Please read all these safety instructions before using this machine.

**DANGER** - To reduce the risk of electric shock, do not leave the machine unattended when plugged in. Always unplug this machine from the electric outlet immediately after using and before cleaning.

**WARNING** - To reduce the risk of burns, fire, electric shock, or injury to persons:

- Do not allow this machine to be used as a toy. Pay close attention when this machine is used by or near children.
- Use this machine only for its intended use as described in this manual. Use only attachments recommended by the manufacturer as contained within this manual.
- Never operate this machine if it has a damaged cord or plug, it is not working properly, or it has been dropped, damaged, or dropped into water. Return the machine to the nearest authorized dealer or service center for examination, repair, or electrical or mechanical adjustment.
- Never operate the machine with any air openings blocked. Keep ventilation openings of the quilting machine free from the accumulation of lint, dust, and loose cloth.
- Never drop or insert any object into any opening.
- Do not use outdoors.
- Do not operate where aerosol (spray) products are being used or where oxygen is being administered.
- To disconnect, turn all controls to the off position, then remove the plug from the outlet by grasping the plug. Do not pull on cord.
- Keep fingers away from all moving parts. Special care is required around the quilting machine needle.
- Always use the proper needle plate. The wrong plate can cause the needle to break.
- Do not use bent needles.
- Do not pull or push fabric while stitching. It may deflect the needle causing it to break.
- Switch the quilting machine off when making any adjustments in the needle area, such as threading the needle, changing the needle, or changing the presser foot, etc.
- Always unplug the quilting machine from the electrical outlet when removing covers, lubricating, or when making any other user servicing adjustments mentioned in the instruction manual.

If using this machine in an area with inconsistent input power, it is recommended the surge protector is connected to a backup battery supply.

Connect this machine to a properly grounded outlet only. See "Grounding Instructions" (next page).

**SAVE THESE INSTRUCTIONS**

**Do not discard box or packaging**

## GROUNDING INSTRUCTIONS

This product must be grounded. In the event of malfunction or breakdown, grounding provides a path of least resistance for electric current to reduce the risk of electric shock. This product is equipped with a cord that has an equipment-grounding conductor and a grounding plug. Plug the cord from the quilting machine into a surge protector. The surge protector must be plugged into an appropriate outlet that is properly installed and grounded in accordance with all local codes and ordinances.

**DANGER** - Improper connection of the equipment-grounding conductor can result in a risk of electric shock. The conductor with insulation having an outer surface that is green, with or without yellow stripes, is the equipment-grounding conductor. If repair or replacement of the cord or plug is necessary, do not connect the equipment-grounding conductor to a live terminal. Check with a qualified electrician or serviceman if the grounding instructions are not completely understood, or if in doubt as to whether the product is properly grounded.

Do not modify the plug provided with the product — if it will not fit the outlet, have a proper outlet installed by a qualified electrician.

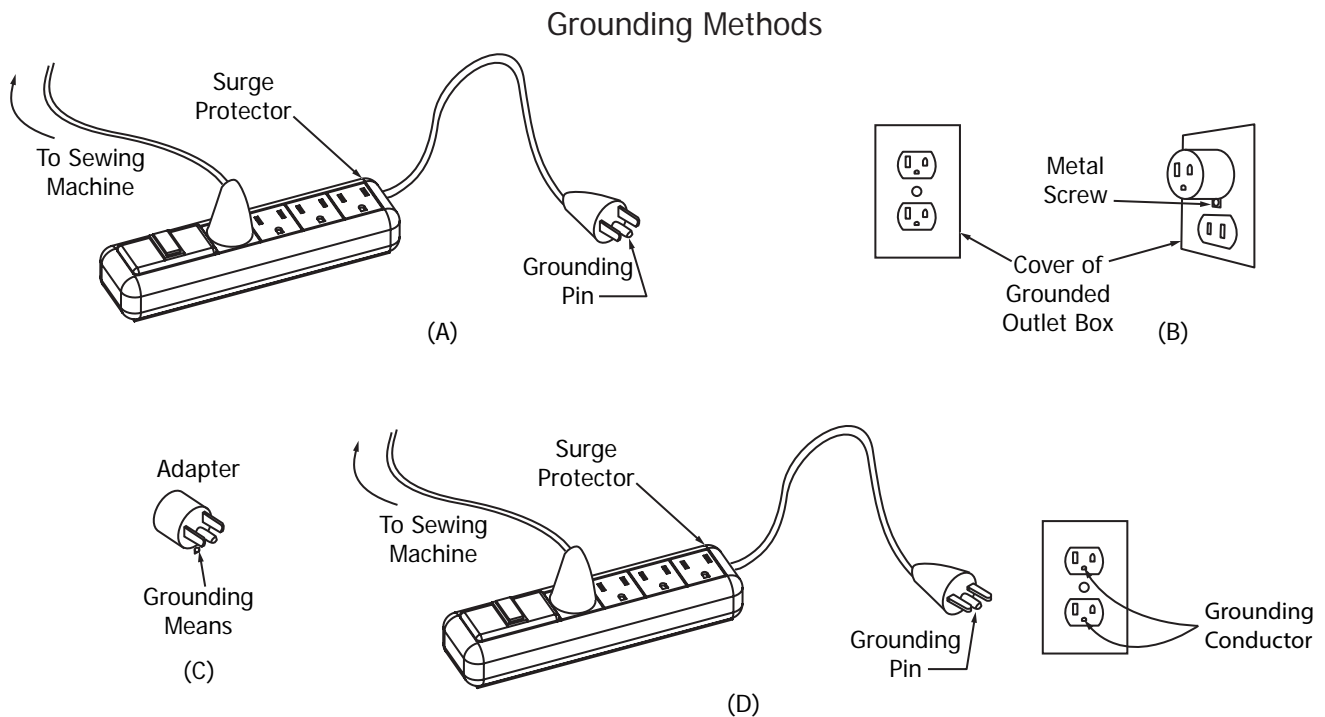

This product is for use on a nominal 120 V circuit, and has a grounding pin as illustrated above (A). A temporary adapter, shown in (B) and (C), may be used to connect this plug to a 2-pole receptacle (B) if a properly grounded outlet is not available. The temporary adapter should be used only until a properly grounded outlet can be installed by a qualified electrician. The green colored rigid ear, lug, and the like, extending from the adapter must be connected to a permanent ground such as a properly grounded outlet box cover. Whenever the adapter is used, it must be held in place by the metal screw.

**A qualified electrician should be consulted if there is any doubt as to whether an outlet box is properly grounded.**

# Table of Contents

Important Safety Instructions .....	2	Maintaining the Machine .....	55
Machine Specifications.....	5	Preparing the Oil Bottle.....	56
Machine Layout .....	6	Oiling and Cleaning .....	57
Ports and Plug-Ins.....	8	Changing the Needle .....	60
Included Parts & Tools .....	9	Adjusting the Bobbin Cam.....	62
<b>Out-of-the-Box Assembly .....</b>	<b>12</b>	Adjusting the Hopping Foot.....	63
Installing the Wheels .....	13	Height Adjustment.....	63
Installing the Wheel Covers .....	16	Rotation Instructions.....	64
Installing the Handlebars.....	17	Removal Instructions.....	66
Connecting the Display .....	19	Installation Instructions .....	67
Attaching the Thread Stand .....	20	Reinstalling the Needle Plate .....	68
Installing the Upper Encoder .....	21	Removal Instructions.....	68
Installing the Lower Encoder .....	23	Installation Instructions .....	69
Turning the Machine On/Off.....	25	<b>Repairs and Diagnostics .....</b>	<b>70</b>
<b>Preparing to Quilt .....</b>	<b>26</b>	<b>Checking the Firmware .....</b>	<b>71</b>
Choosing Machine Settings .....	27	Replacing the Encoder Spring .....	72
Winding a Bobbin .....	29	Reinstalling the Hook Holder .....	75
Loading the Bobbin Case.....	31	Removal Instructions.....	75
Threading the Machine.....	33	Installation Instructions .....	76
Final Checklist .....	38	Timing the Machine .....	78
<b>Quilting.....</b>	<b>39</b>	<b>Appendix .....</b>	<b>82</b>
Using the Handlebar Controls .....	40	Choosing Your Needle .....	83
Using the Precise Quilting Mode .....	41	Choosing Your Thread .....	85
Using the Cruise Quilting Mode.....	43	Choosing Your Fabric and Batting .....	88
Using the Baste Quilting Mode .....	45	Troubleshooting Guide .....	89
Using the Manual Quilting Mode .....	47	<b>Index.....</b>	<b>91</b>
Estimating Bobbin Fill Levels.....	49		
Adjusting Thread Tension.....	50		
Taking Measurements .....	52		
Making Calculations .....	53		
Tracking Stitch Count & Run Time.....	54		

# Machine Specifications

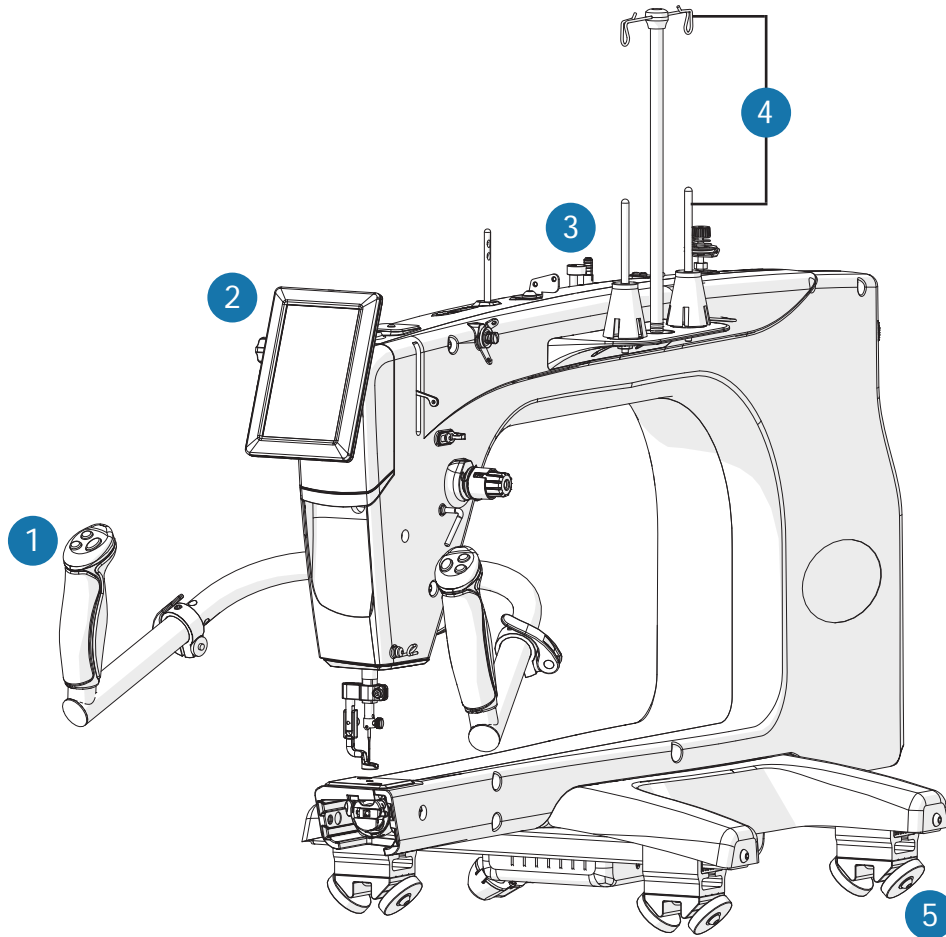

## Product Dimensions

### Body:

- Height: 515 mm, or 20.25 inches
- Width: 395 mm, or 15.5 inches
- Length: 824 mm, or 32.4 inches
- Weight: 24.5 kg, or 54 lbs

### Quilting Arm:

- Height: 266.7 mm, or 10.5 inches
- Width: 533.4 mm, or 21 inches

## Electrical

- Input Voltage: 110-220 VAC
- Peak Power Consumption: 450 W

## Features

- 1 Ergonomic handles and handlebars for efficient, extended use (page 17)
- 2 5" Touch display (page 19)
- 3 Built in bobbin winder (page 29)
- 4 Dual thread mast and stands for quilting and winding bobbin at the same time
- 5 Dual wheels for added stability (page 13)
- 6 Range of 130 to 2600 stitches per minute
- 7 Regulated stitching

# Machine Layout

## Quilting Machine (Side View)

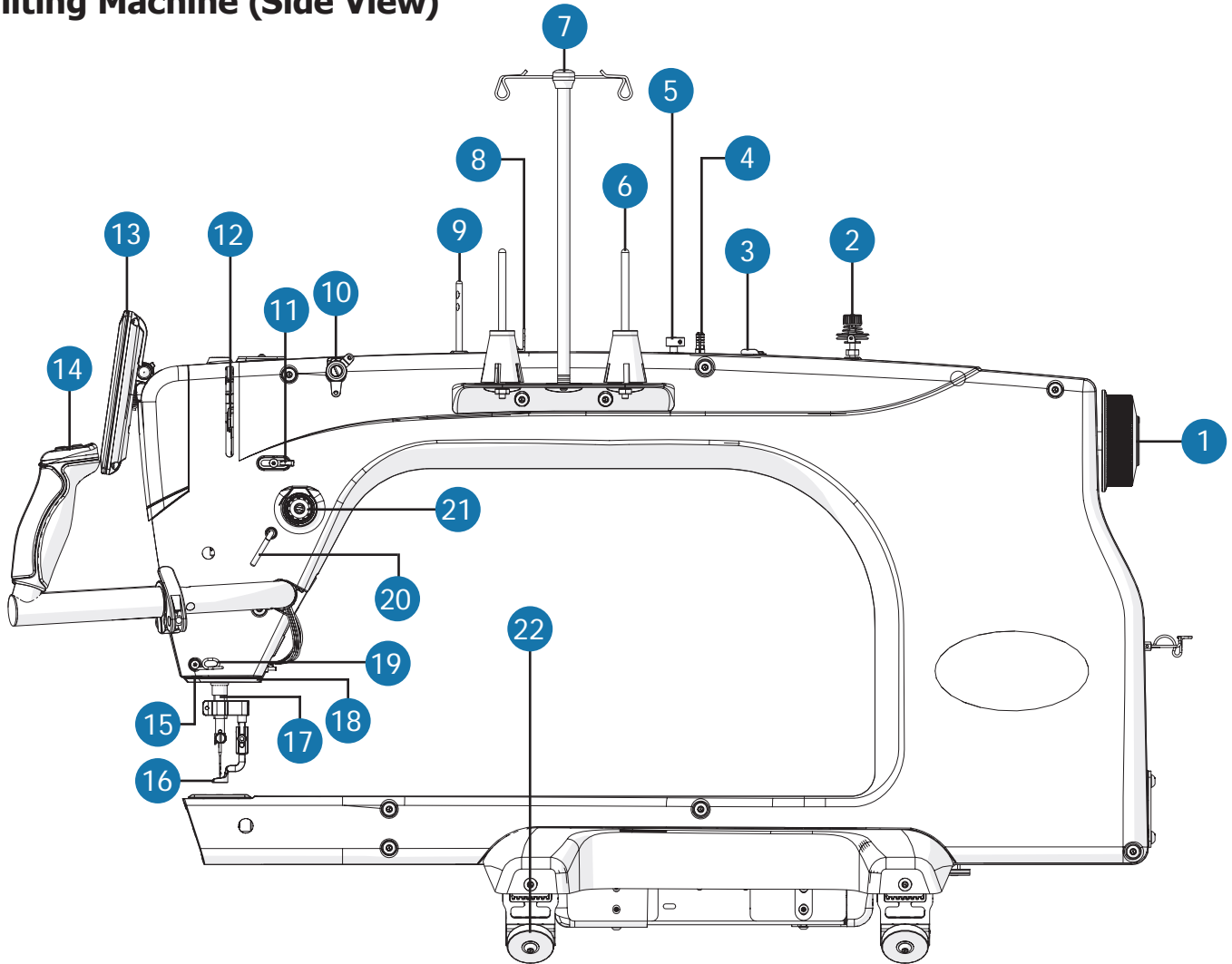

- 1 Hand Wheel**  
Raises and lowers the needle bar.
- 2 Bobbin Thread Tensioner** (page 29)  
Tensions thread for winding a bobbin.
- 3 Bobbin Thread Cutter** (page 29)  
Cuts wound bobbin thread.
- 4 Bobbin Stand** (page 29)  
Positions bobbin for winding.
- 5 Bobbin Cam** (page 29)  
Starts and stops bobbin winding.
- 6 Thread Stand** (page 33)  
Holds a cone of thread.
- 7 Thread Mast** (page 33)  
Guides the thread for quilting.
- 8 Bobbin Thread Guide** (page 29)  
Guides thread for winding a bobbin.
- 9 Thread Guide Rod** (page 33)  
Positions thread when quilting.
- 10 Small Thread Tensioner** (page 33)  
Tensions thread when quilting.
- 11 Thread Guide** (page 33)  
Positions thread when quilting.
- 12 Take-Up Lever** (page 33)  
Tensions thread when quilting.

- 13 Display** (page 19)  
Provides access to quilting options.
- 14 Handlebar Controls** (page 40)  
Controls machine functions.
- 15 Lamp** (page 27)  
Lights up needle area.
- 16 Hopping Foot** (page 63)  
Presses fabric down when quilting.
- 17 Needle Bar** (page 60)  
Holds the needle when quilting.
- 18 Thread Cutter** (page 33)  
Cuts excess thread after threading machine.
- 19 Bottom Thread Guide** (page 33)  
Positions thread when quilting.
- 20 Thread Guide** (page 33)  
Positions thread when quilting.
- 21 Large Thread Tensioner** (page 50)  
Tensions thread as adjusted.
- 22 Machine Wheels** (page 13)  
Rides the bottom carriage rails to move machine up or down on the quilting frame.

## Hook Assembly (Front View)

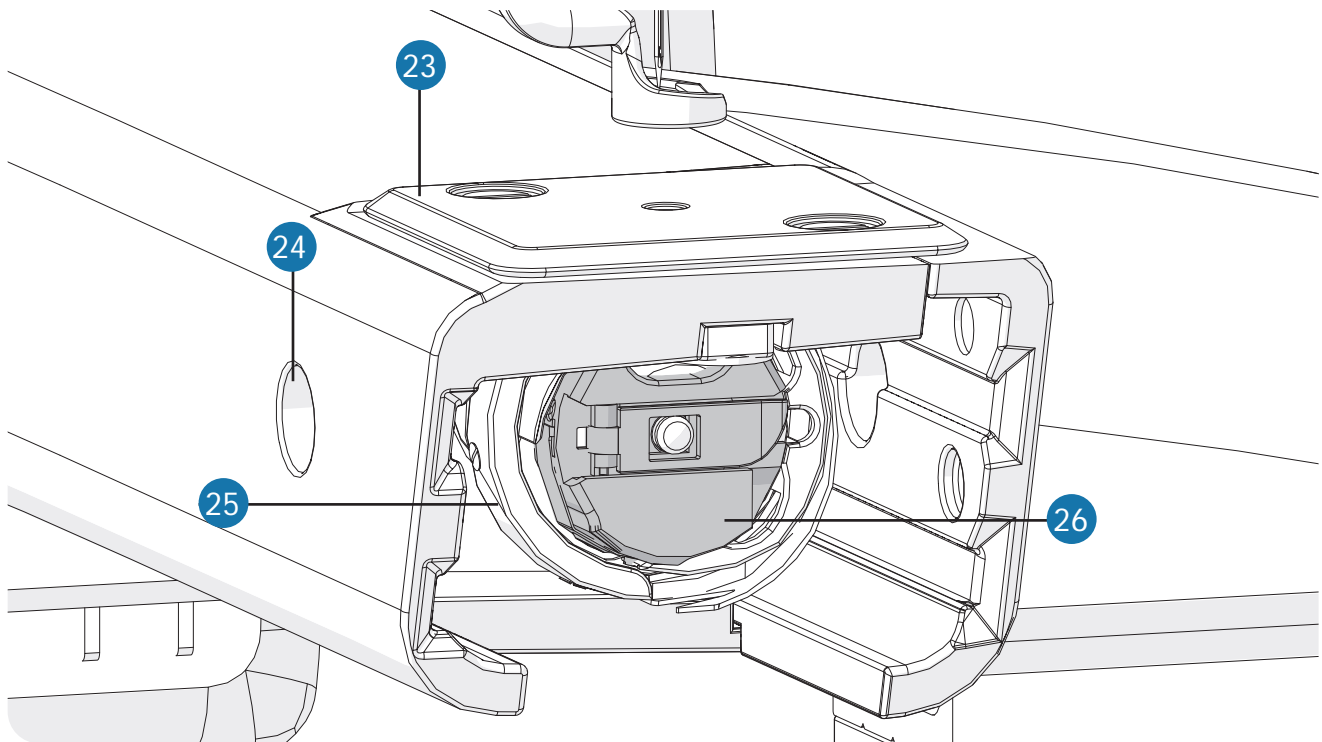

- 23 Needle Plate** (page 68)  
Covers top hook assembly access.
- 24 Timing Cut-Out** (page 78)  
Accesses hook assembly set screws.
- 25 Hook Assembly** (page 31)  
Holds the bobbin case and hooks the top thread to create stitches.
- 26 Bobbin Case** (page 31)  
Holds M class bobbin and controls bottom thread tension.

# Ports and Plug-Ins

## Quilting Machine (Rear View)

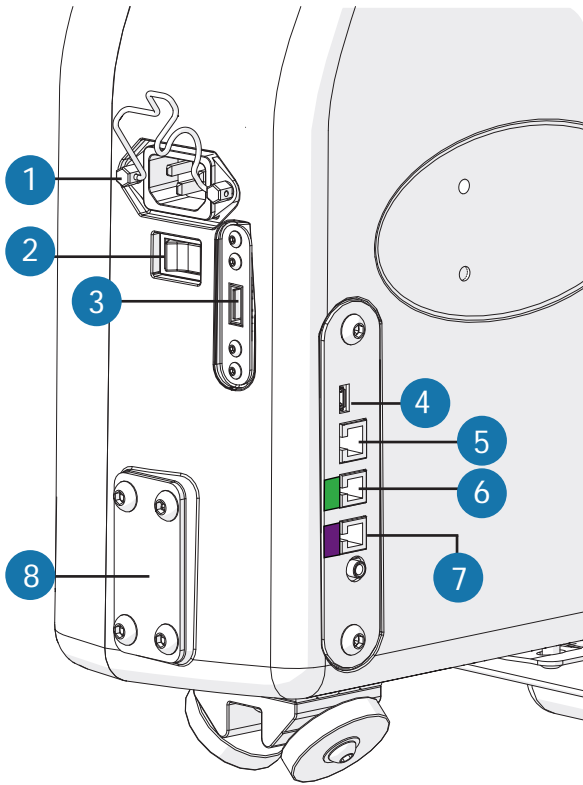

## Quilting Machine (Front View)

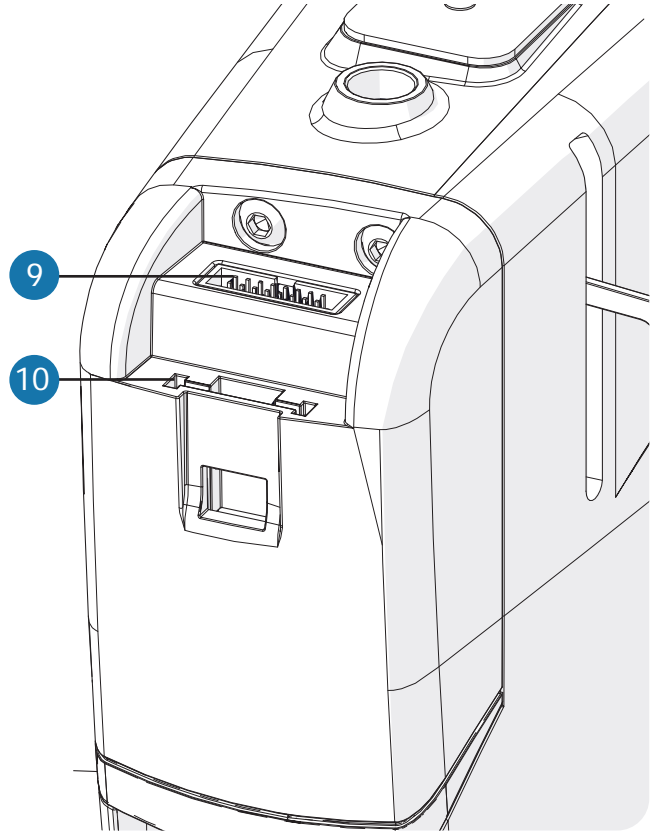

- 1 Power Port with Retainer** (page 25)  
Connects and holds power cable to the machine.
- 2 Power On/Off Switch** (page 25)  
Turns machine on and off.
- 3 Quilt Motion Tablet Port**  
For optional automation accessory.
- 4 USB Connector Port**  
For updating only.
- 5 Quilt Motion Port**  
For optional automation accessory.

- 6 Lower Encoder Port** (page 234)  
Connects lower encoder to machine.
- 7 Upper Encoder Port** (page 2122)  
Connects upper encoder to machine.
- 8 Back Handle Port Cover**  
For optional back handle accessory.
- 9 Display Cable Port** (page 19)  
Connects display cable to machine.
- 10 Display Clip Port** (page 19)  
Connects display clip to machine.



# Included Parts & Tools

Please make sure all pieces are included in your kit.

**Back Wheel Support Assembly**

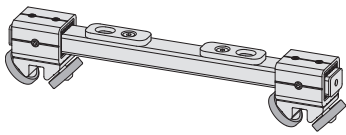

SMP-09-13185  
See page 13

**Front Wheel Support Assembly**

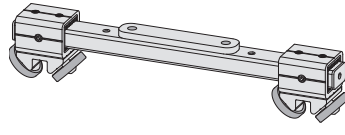

SMP-09-13184  
See page 13

**Plastic Base - Right**

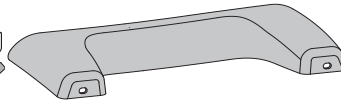

SMP-05-11705  
See page 16

**Plastic Base - Left**

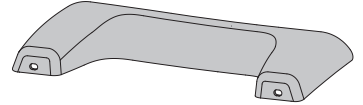

SMP-05-11704  
See page 16

**Handlebar Assembly**

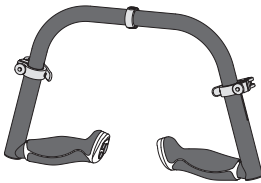

SMP-09-14066  
See page 17

**Thread Mast Assembly**

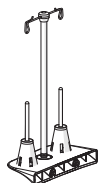

SMP-09-13183  
See page 20

## Box 1

**5 Inch Touch Display**

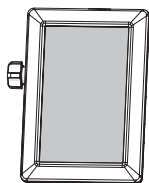

SMP-09-14109  
See page 19

## Box 2

**T-handle Allen Wrench 4 mm**

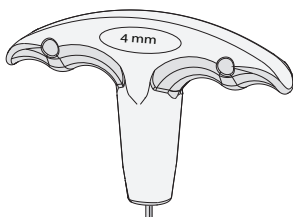

HDW-03-13114

**T-handle Allen Wrench 3 mm**

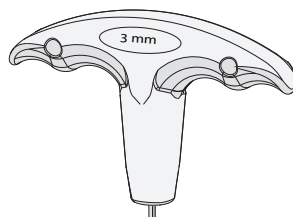

HDW-03-13115

**T-handle Allen Wrench 2.5 mm**

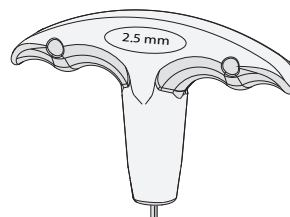

HDW-03-13116

**T-handle Allen Wrench 2 mm**

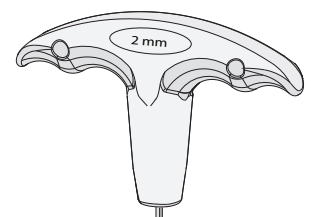

HDW-03-13117

## Box 2 Continued

### Lint Brush

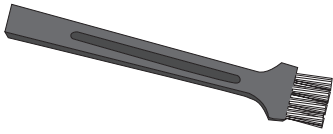

SMP-03-10170  
See page 57

### Needle Size 18 (x11) (one pre-installed)

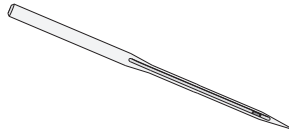

ACC-01-11025  
See page 60

### Needle Size 16 (x10)

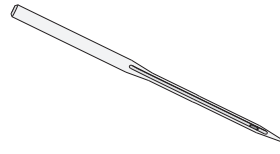

ACC-01-11024  
See page 60

### Needle Magnet

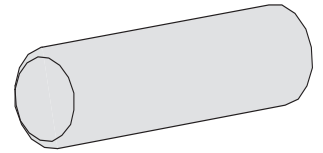

SMP-09-13837  
See page 60

### Flat-head Screwdriver

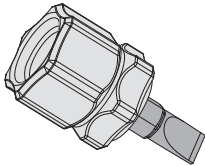

SMP-03-10169  
See page 68

### Hopping Foot Height tool

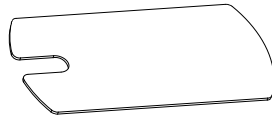

SMP-03-12171  
See page 63

### M Class Bobbin (x3) (two pre-installed)

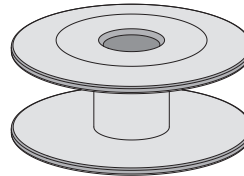

SMP-08-10070  
See page 29

### Timing Spacer Tool

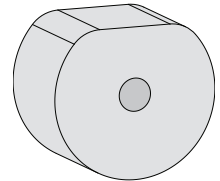

SMP-03-11320  
See page 78

## Box 3

### Upper Encoder (silver spring)

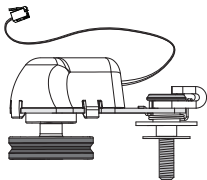

SMP-09-15024  
See page 21

### Lower Encoder (black spring)

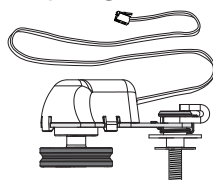

SMP-09-15033  
See page 23

### Zip Tie (x2) Zip Tie Mount (x2)

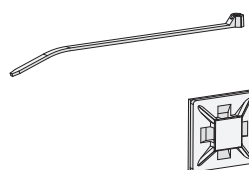

MIS-08-10805

### Upper Encoder Spring (silver)

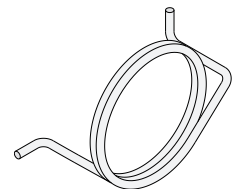

HDW-03-10216  
See page 72

### Lower Encoder Spring (black)

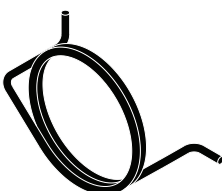

HDW-03-10671  
See page 72

## Box 4

### **SBHCS Screw M6 x 20 mm (x2)**

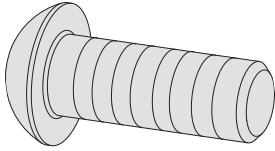

HDW-03-10088  
See page 13

### **Shoulder Bolt M6 (x2)**

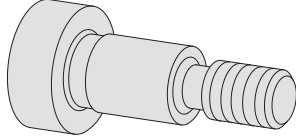

HDW-03-12206  
See page 13

### **SBHCS Screw M6 x 14 mm (x6)**

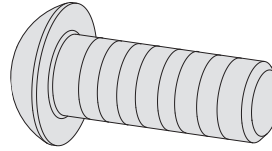

HDW-03-10974  
See page 16, 20

### **Hopping Foot Screw**

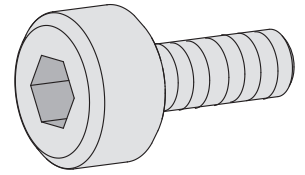

HDW-03-10966  
See page 63

### **M3 Thumb Screw (needle bar spare)**

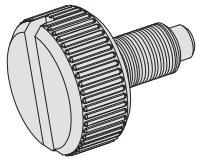

HDW-03-11736  
See page 60

### **Oil Bottle**

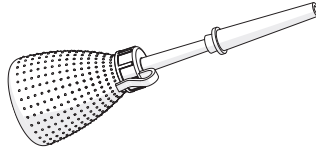

SMP-09-13888  
See page 57

### **Power Cord**

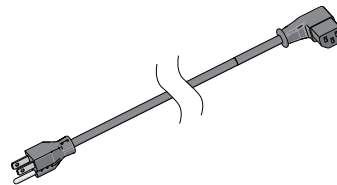

SMP-02-14466  
See page 25

# Out-of-the-Box Assembly

These steps are for assembling the machine when it is first removed from the packaging materials. Please set up your quilting frame prior to machine assembly.

<b>Installing the Wheels</b> .....	<b>page 13</b>
<b>Installing the Wheel Covers</b> .....	<b>page 16</b>
<b>Installing the Handlebars</b> .....	<b>page 17</b>
<b>Connecting the Display</b> .....	<b>page 19</b>
<b>Attaching the Thread Stand</b> .....	<b>page 20</b>
<b>Installing the Upper Encoder</b> .....	<b>page 21</b>
<b>Installing the Lower Encoder</b> .....	<b>page 23</b>
<b>Turning the Machine On/Off</b> .....	<b>page 25</b>

**Tip:** For additional help, scan the QR code below with the camera on your smart phone to visit our online support videos!



<https://www.graceframe.com/en/resources/support/videos>

## Installing the Wheels

Set up the frame before assembling the machine.

### Parts & Tools Needed:

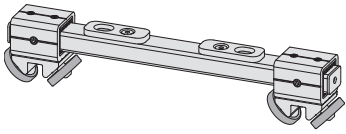

Back Wheel Support Assembly

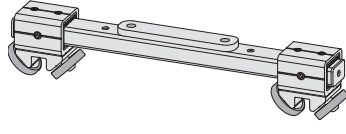

Front Wheel Support Assembly

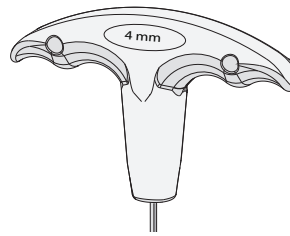

T-handle Allen Wrench 4 mm

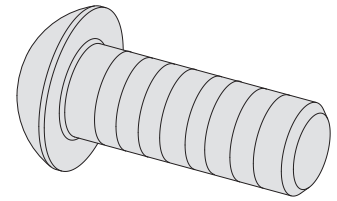

SBHCS Screw M6 x 20 mm (x2)

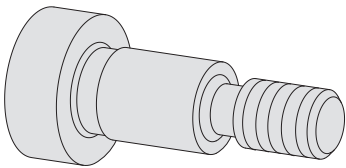

Shoulder Bolt M6 (x2)

- Tape Measure (not included)

### Instructions

To install and adjust the machine wheels:

- 1 Place the **back wheel support assembly** under the rear of the machine with the **set screws** facing the rear.

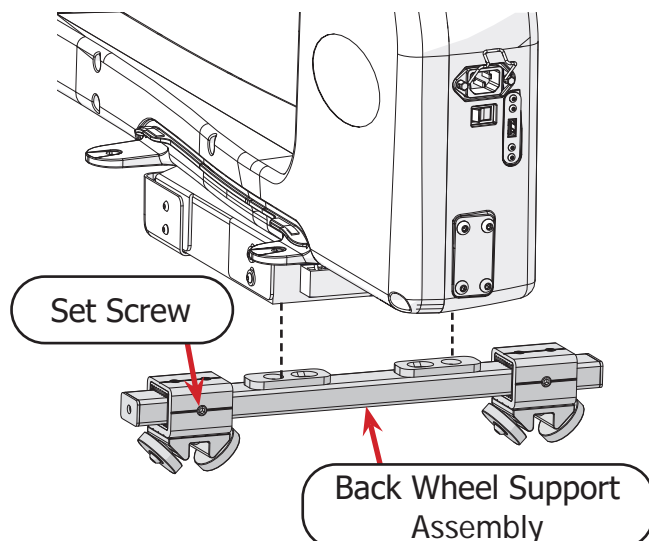

- 2 Use two **M6 x 20 SBHCS screws** and the 4 mm Allen wrench to secure the wheel support assembly.

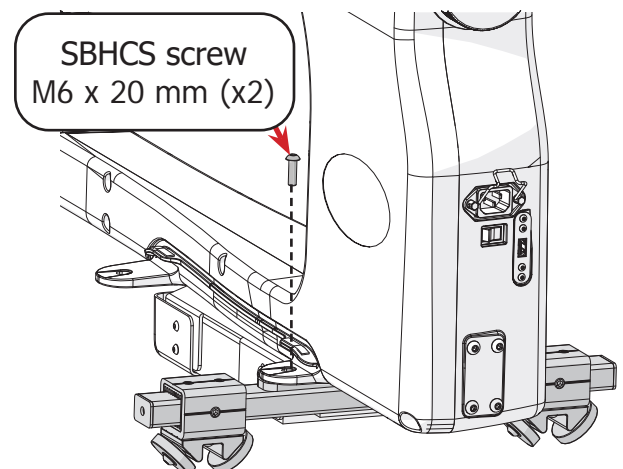

# Out-of-the-Box Assembly

## Installing the Wheels (Continued)

- 3 Place the **front wheel support assembly** under the front of the machine, with the **set screws** facing the rear.

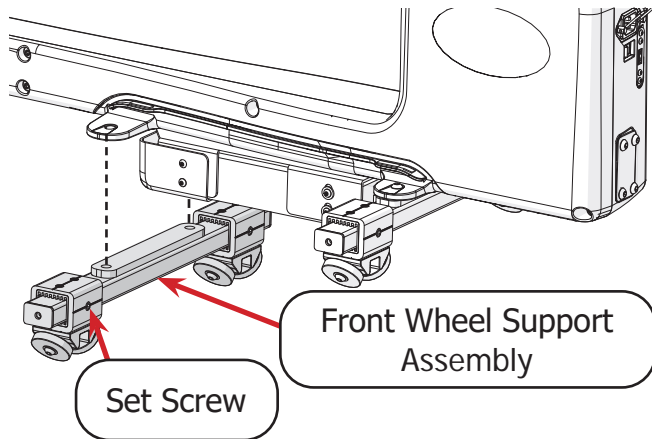

- 4 Use two **M6 shoulder bolts** and the 4 mm Allen wrench to screw the wheel support to the machine.

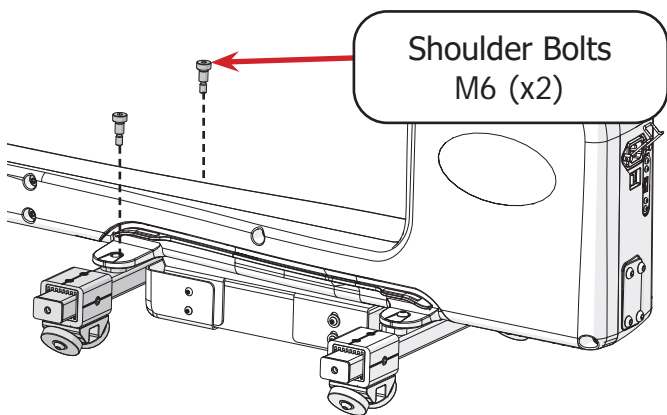

- 5 Place the machine onto the bottom carriage so that the tracks align with the wheels.

**Tip:** See your frame manual for bottom carriage orientation.

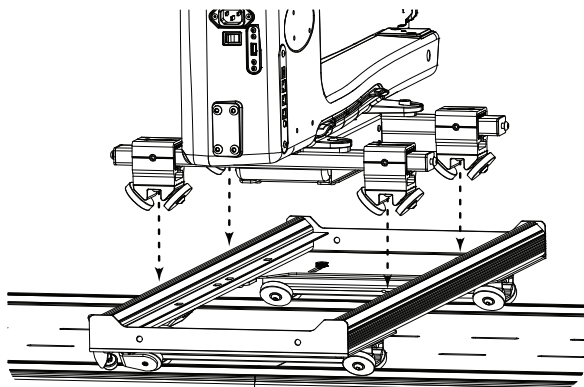

- 6 Loosen two set screws on one side of the machine (either the right side or left side) with the 4 mm Allen wrench.

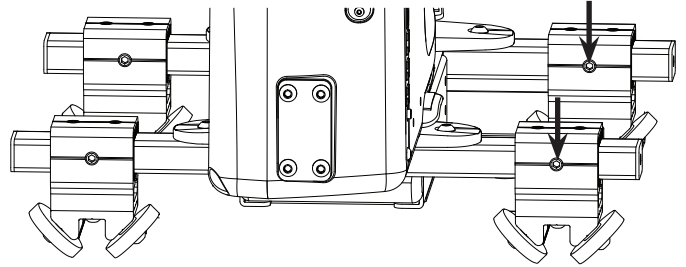

- 7 Slide the machine up and down the bottom carriage tracks. The machine should move smoothly.

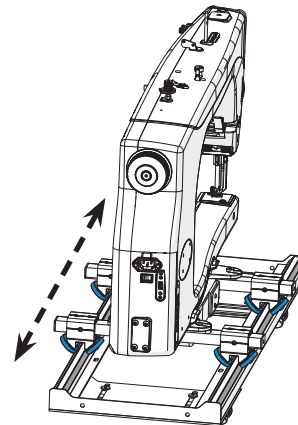

- 8 Check that the machine is centered over the wheels. If needed, loosen all four wheel block set screws and shift the machine from side to side.

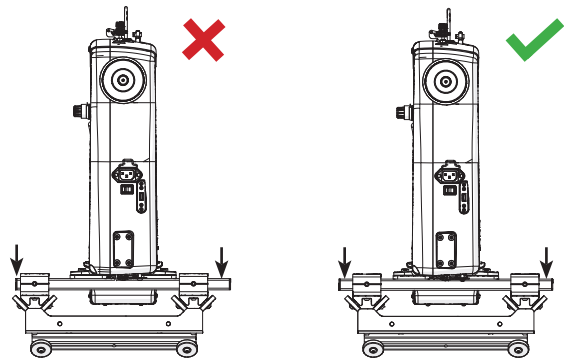

## Installing the Wheels (Continued)

- 9 Re-tighten the wheel block set screws you loosened earlier with the 4 mm Allen wrench.

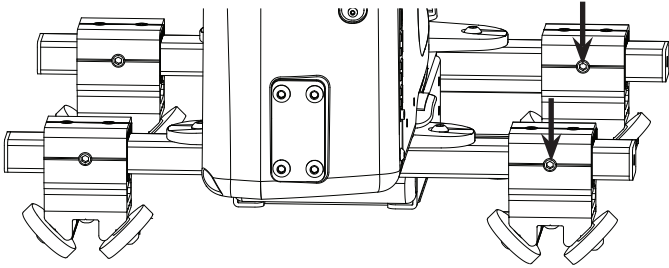

## Out-of-the-Box Assembly

# Installing the Wheel Covers

### Parts & Tools Needed:

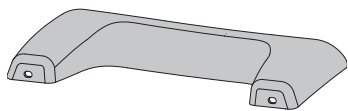

Plastic Base - Left

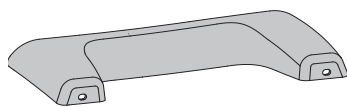

Plastic Base - Right

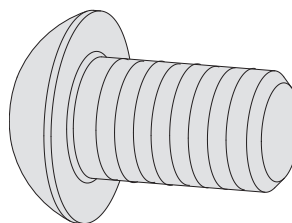

SBHCS Screw  
M6 x 14 mm (x4)

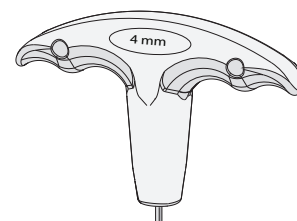

T-handle Allen  
Wrench 4 mm

### Instructions

Take the following steps to install the wheel covers onto the machine:

- 1 Slide the **right plastic base** onto the right side of the machine, over the **side ridge**. Screw in place with two **M6 x 16 mm SBHCS screws** and the 4 mm Allen wrench. Tighten until snug.

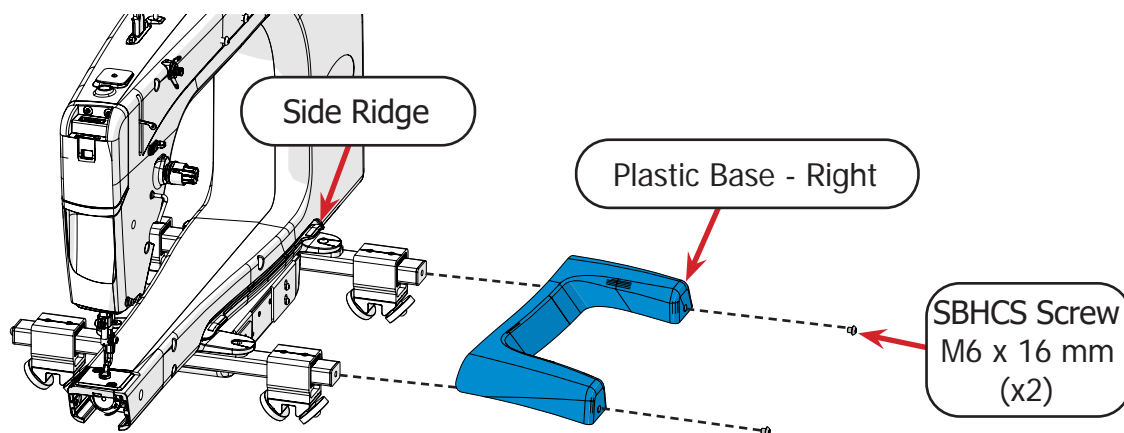

- 2 Slide the **left plastic base** onto the left side of the machine, over the **side ridge**. Screw in place with two **M6 x 16 mm SBHCS screws** and the 4 mm Allen wrench. Tighten until snug.

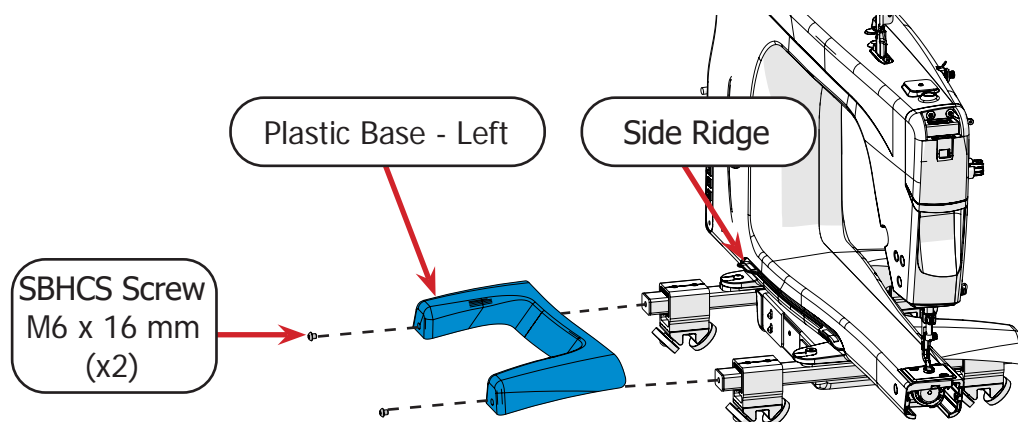



## Installing the Handlebars

### Parts & Tools Needed:

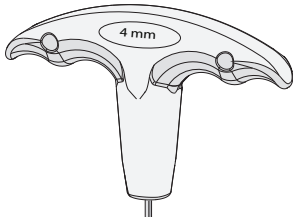

T-handle Allen Wrench 4 mm

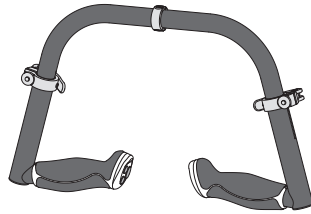

Handlebar Assembly

### Instructions

Take the following steps to install the machine handlebars:

- 1 With the 4 mm Allen wrench, remove **handlebar cover screw**.

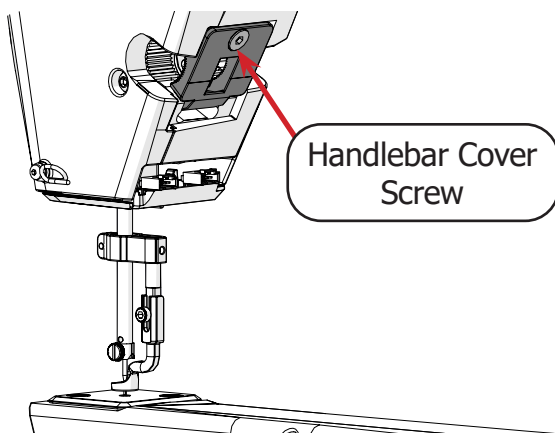

The **handlebar cover** opens.

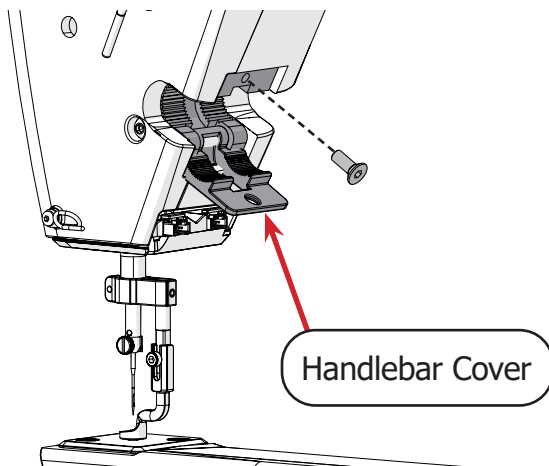

- 2 Slide the handlebars into the slot so the **handlebar cables** are on the bottom.

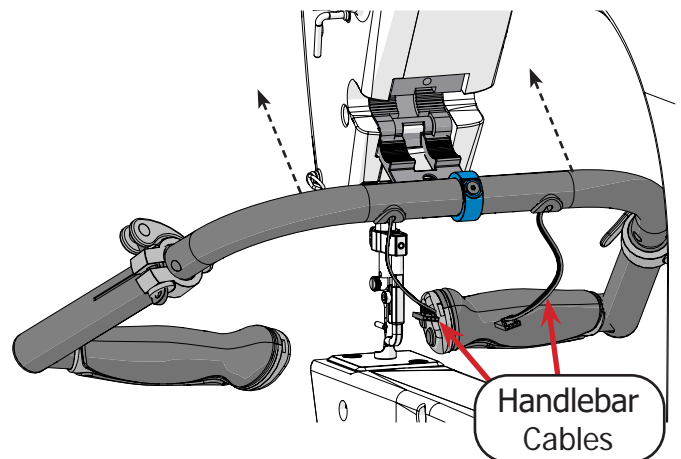

- 3 Close the cover and loosely screw in the cover screw.

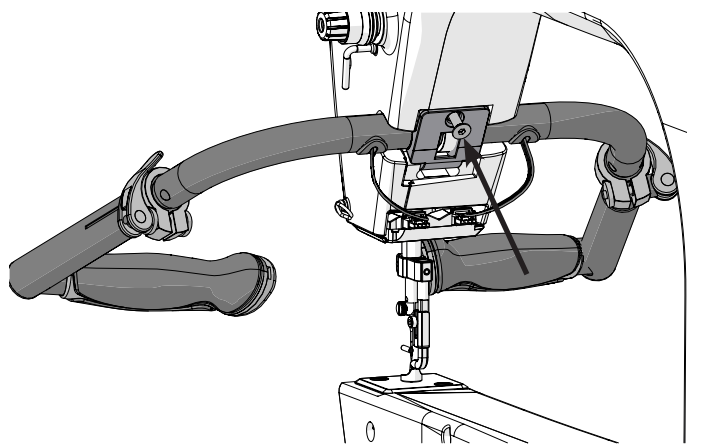

# Out-of-the-Box Assembly

## Installing the Handlebars (Continued)

- 4 Hold the handlebars at the desired angle and tighten the cover screw.

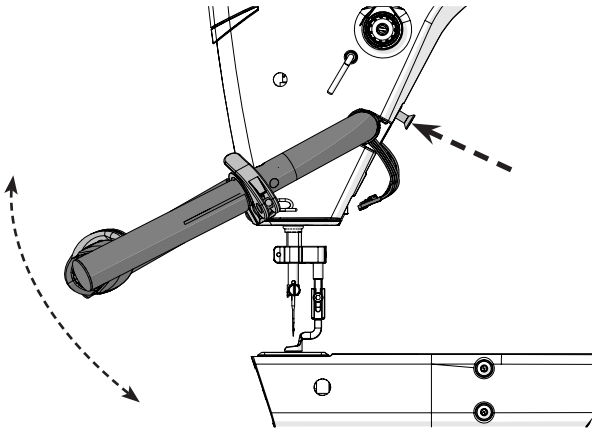

- 5 Plug the cables from the handlebars into the machine.

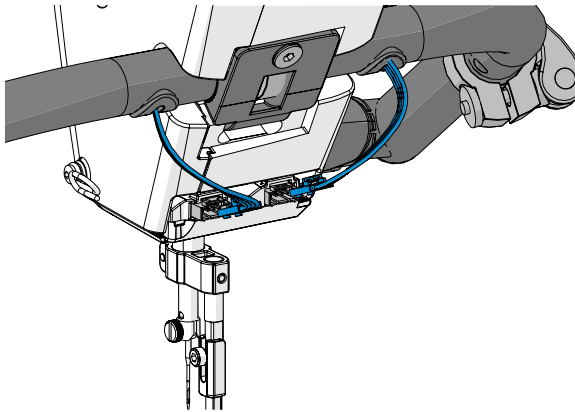

- 6 Open the **handlebar levers** (shown in blue).

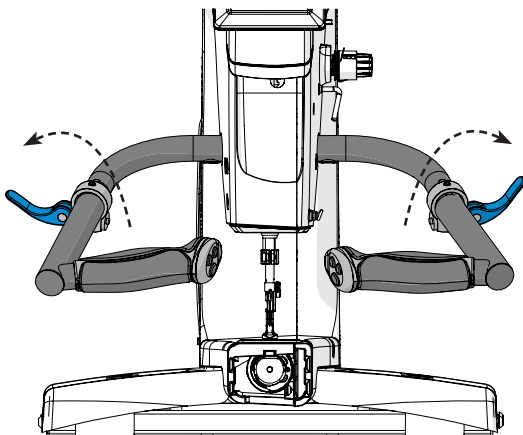

- 7 Twist the controls until they are comfortable to hold and operate.

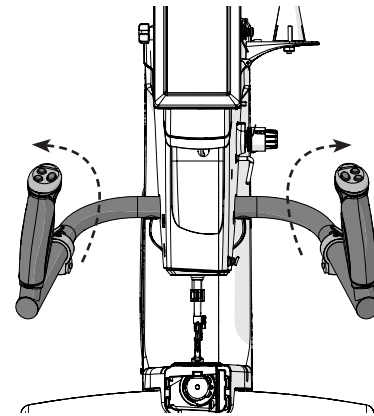

- 8 Close the handlebar levers (shown in blue). If needed, loosen the cover screw and repeat step 4.

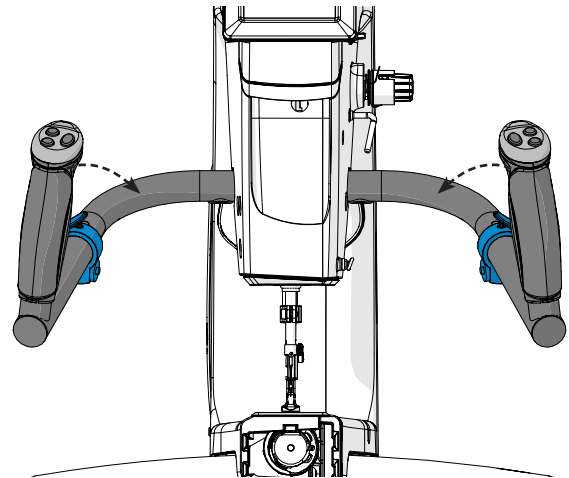

**Tip:** For micro-stippling, angle the handlebars down toward the needle plate in step 4, and leave the controls horizontal in step 7.

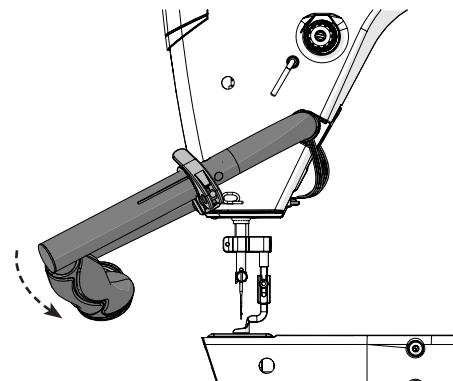

## Connecting the Display

### Parts & Tools Needed:

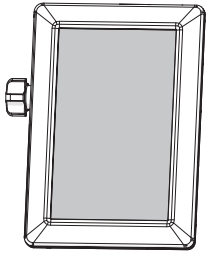

5 Inch Touch Display

### Instructions

Take the following steps to install the display.

- 1 If not already done, plug one end of the **ribbon cable** into the display. Weave the cable through the **display clip**.

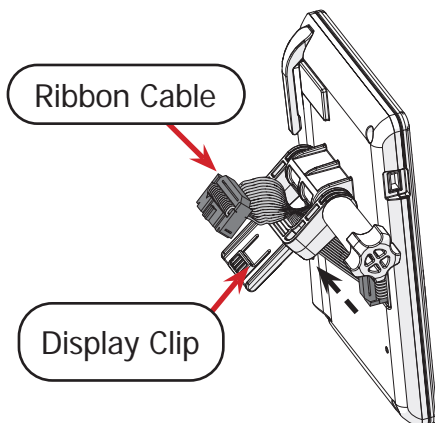

- 2 Slide the display clip into the **clip port** and ribbon cable into the **cable port**.

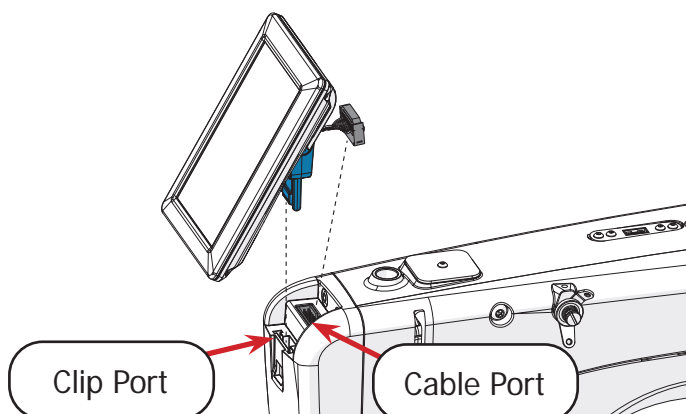

**Note:** To remove the display, power off the machine. Unplug the display ribbon cable. Then lift the bottom of the display up, and press in on the clip release.

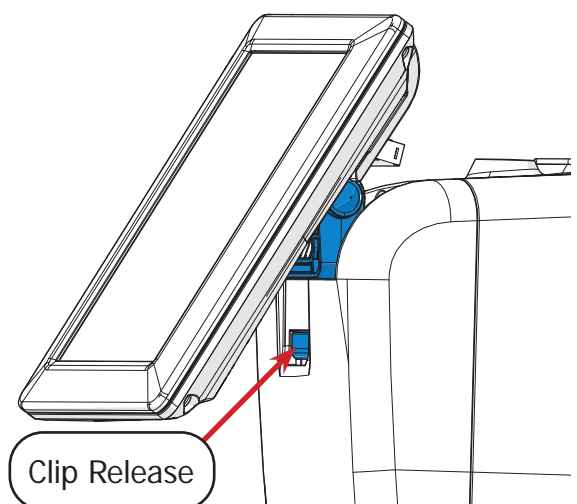
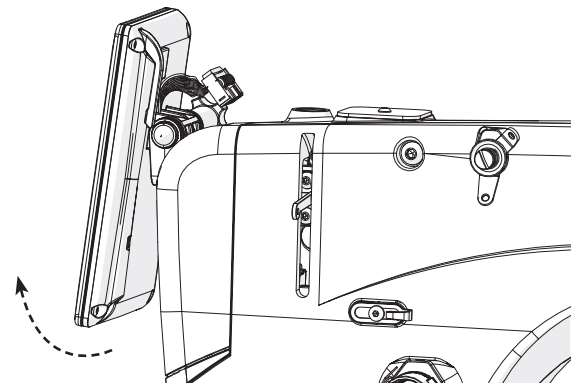

# Out-of-the-Box Assembly

## Attaching the Thread Stand

### Parts & Tools Needed:

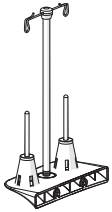

Thread Stand  
Assembly

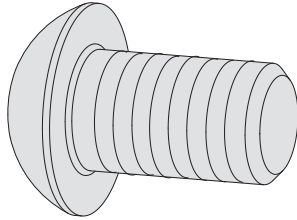

SBHCS Screw  
M6 x 16 mm (x2)

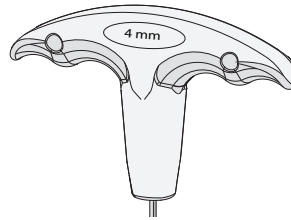

T-handle Allen  
Wrench 4 mm

### Instructions

To install the thread stand assembly:

- Use two **M6 x 14 mm SBHCS screws** and the 4 mm T-handle Allen wrench to install the thread stand assembly on the right side of the machine.

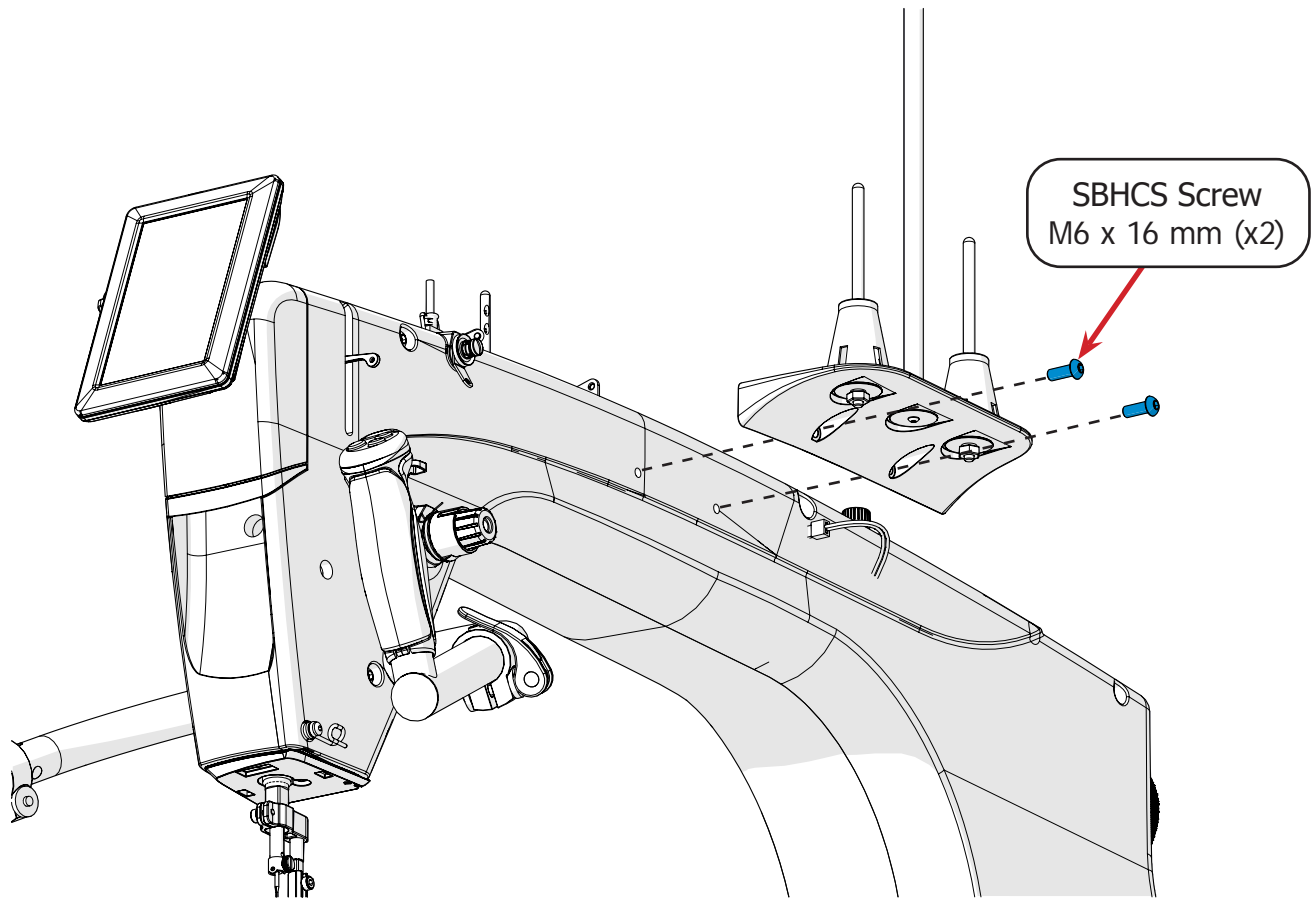

## Installing the Upper Encoder

### Parts & Tools Needed:

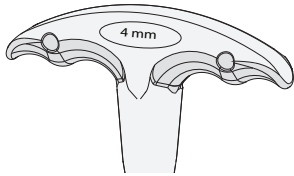

T-handle Allen Wrench 4 mm

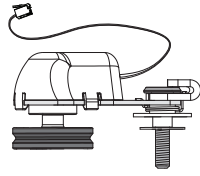

Upper Encoder (silver spring)

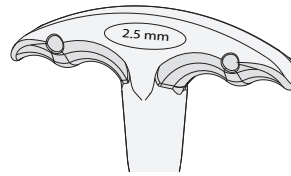

T-handle Allen Wrench 2.5 mm

### Instructions

The encoders monitor the position of the machine on the frame, allowing for regulated stitching. The upper encoder is installed on the outward-facing, left-rear wheel of the machine. Please take the following steps:

- 1 Use the 4 mm T-handle Allen wrench to remove the **left rear wheel** from the machine.

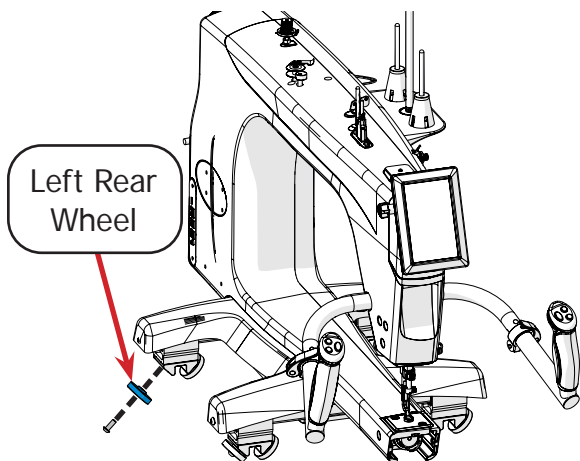

The **wheel screw** will not be needed again and can be stored with the packaging materials.

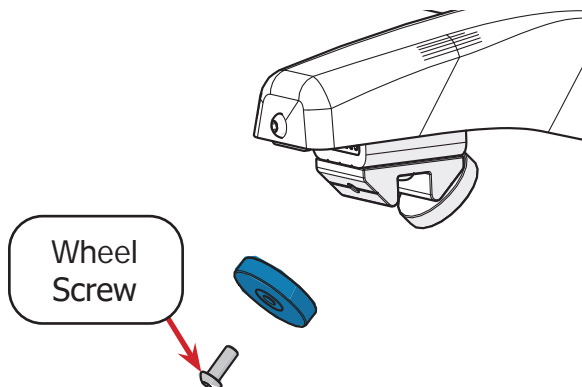

- 2 Loosen the **lock collar screw** on the upper encoder with the 2.5 mm Allen wrench until the **lock collar** turns freely.

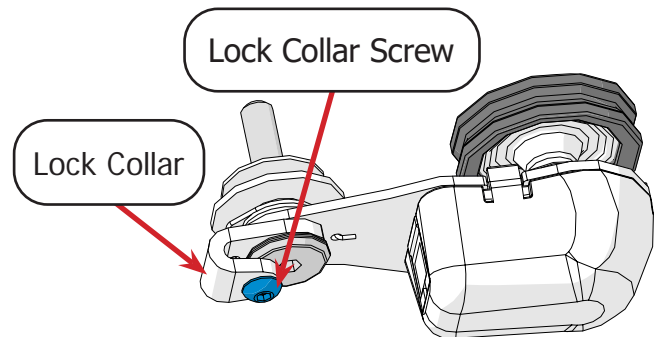

- 3 Slide the wheel onto the upper **encoder screw** so that the **wheel hub** faces away from the encoder.

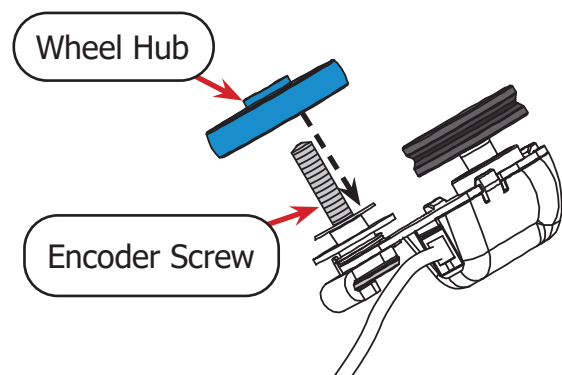

# Out-of-the-Box Assembly

## Installing the Upper Encoder (Continued)

- 4 Place the encoder screw into the left rear wheel hole so the **encoder O-ring** is between the two left machine wheels.

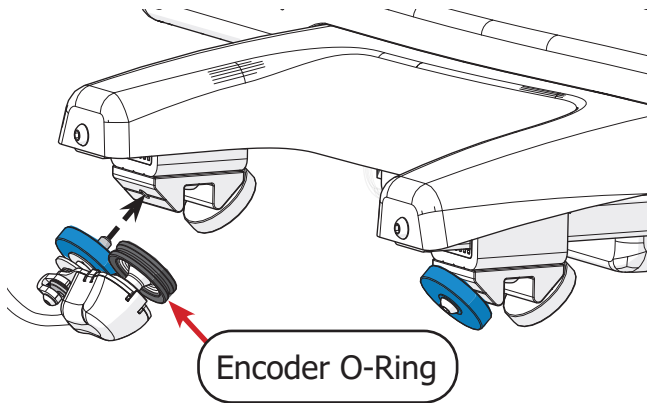

- 5 Tighten the **encoder screw** with the 4 mm Allen wrench.

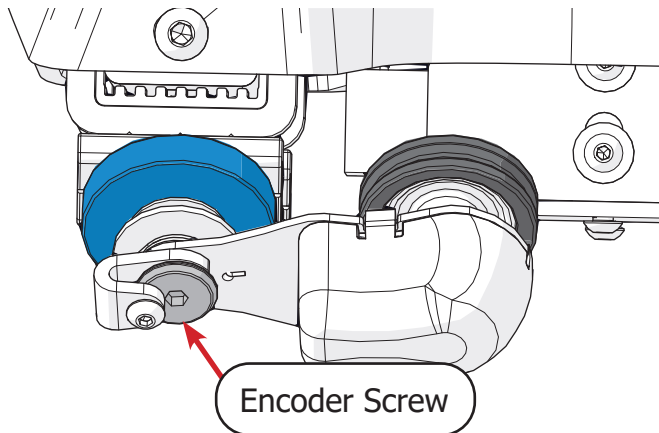

- 6 Turn the **encoder lock collar** (shown in blue) to point up and tighten the **lock collar screw** with the 2.5 mm Allen wrench.

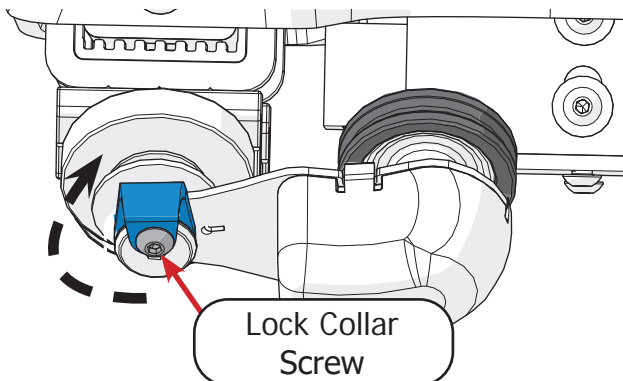

- 7 Plug the encoder cable into the **purple encoder port** on the back left of the machine.

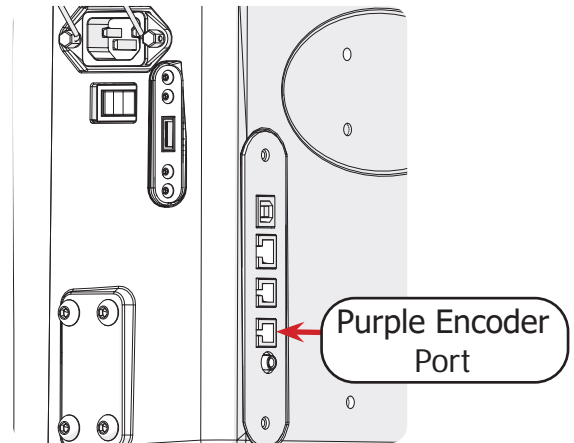

## Installing the Lower Encoder

### Parts & Tools Needed:

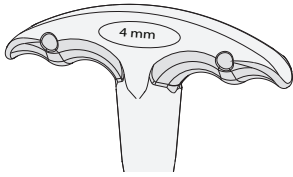

T-handle Allen  
Wrench 4 mm

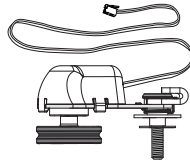

Lower Encoder  
(black spring)

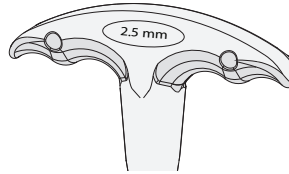

T-handle Allen  
Wrench 2.5 mm

### Instructions

The encoders monitor the movement of the machine on the frame, allowing for regulated stitching. The lower encoder is installed on the left-rear wheel of the bottom carriage. Please take the following steps to install the encoder onto the bottom carriage:

- 1 Locate the left rear wheel of your bottom carriage.

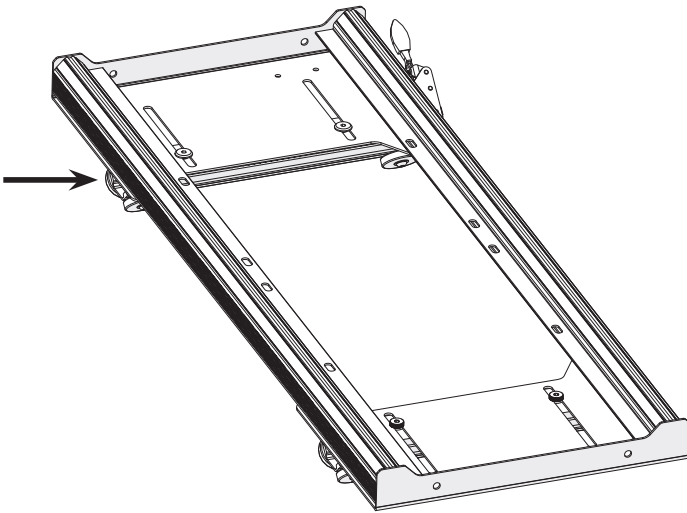

**Note:** If needed, review your frame assembly manual to determine the front of the bottom carriage.

- 2 Use the 4 mm Allen wrench to remove the outward-facing, left rear **wheel** from the bottom carriage.

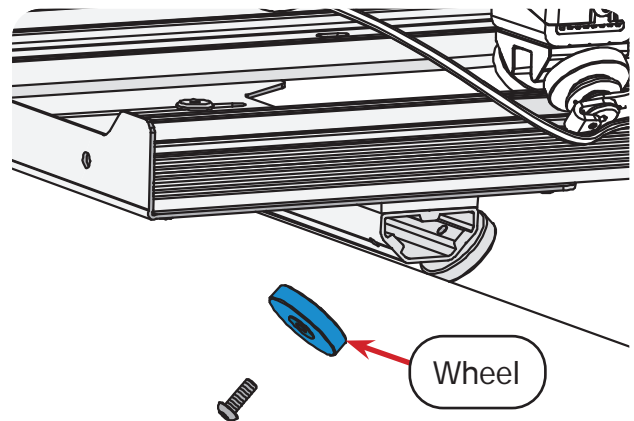

- 3 Loosen the **lock collar screw** on the lower encoder with the 2.5 mm Allen wrench until the **lock collar** turns freely.

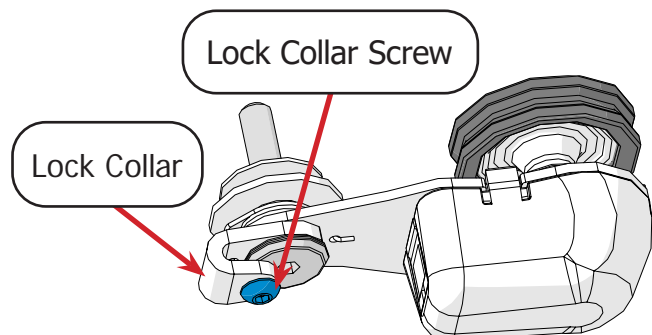

# Out-of-the-Box Assembly

## Installing the Lower Encoder (Continued)

- 4 Slide the wheel onto the **encoder screw** with the **wheel hub** facing away from the encoder.

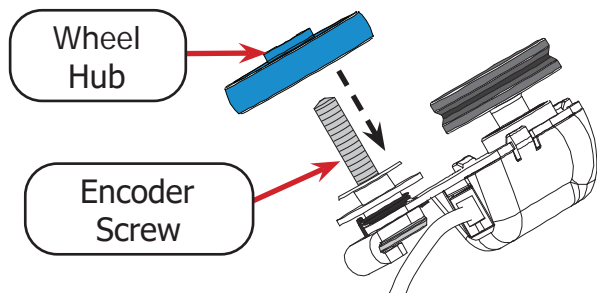

- 5 Place the encoder screw into the left rear wheel hole on the carriage so the **O-ring** is between the rear wheels.

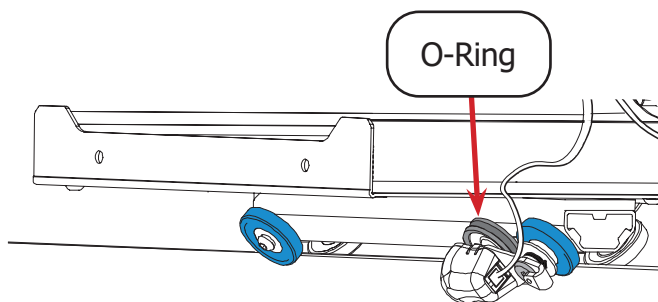

- 6 Tighten the **encoder screw** with the 4 mm Allen wrench.

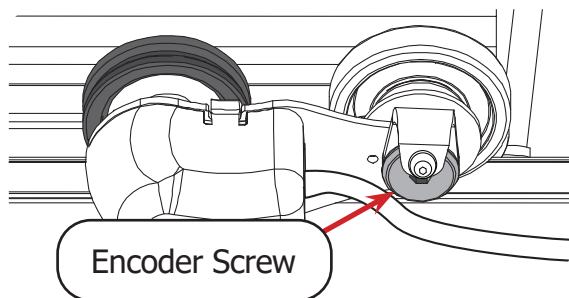

- 7 Turn the encoder **lock collar** (shown in blue) to point up. Then tighten the **lock collar screw** with the 2.5 mm Allen wrench.

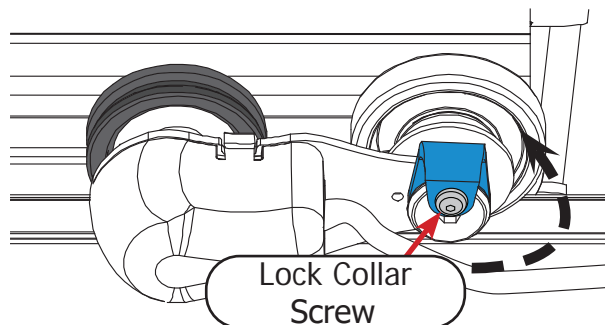

- 8 Take the free end of encoder cable (shown in blue) and pull it through the open slit in the bottom carriage behind the wheels.

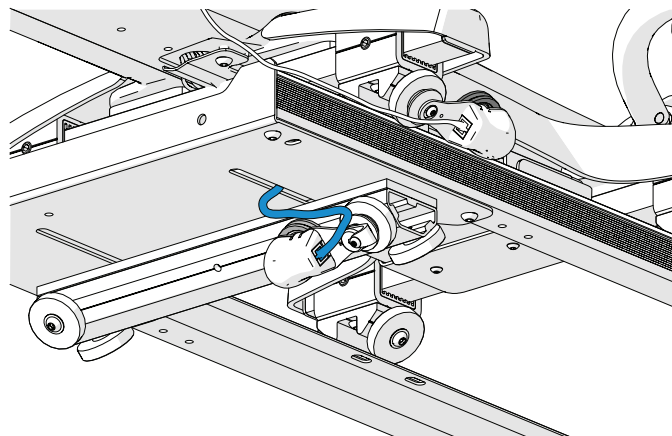

- 9 Plug the encoder cable into the **green encoder port** on the left rear of the machine.

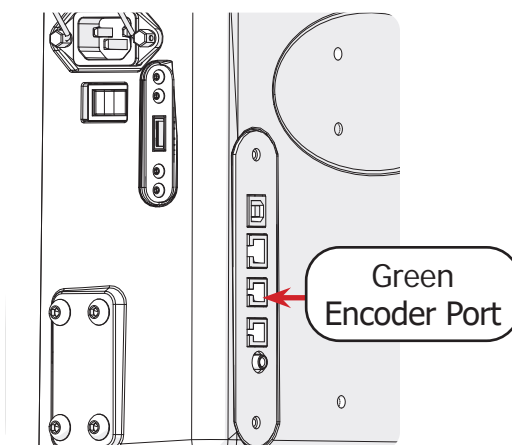



## Turning the Machine On/Off

### Parts & Tools Needed:

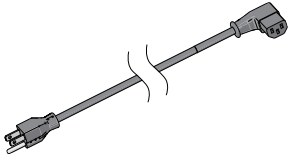

Power Cord

### Instructions

The power cable port and power switch are located on the back of the machine. To power on the machine, take the following steps:

- 1 Lift up the **power cable retainer**.

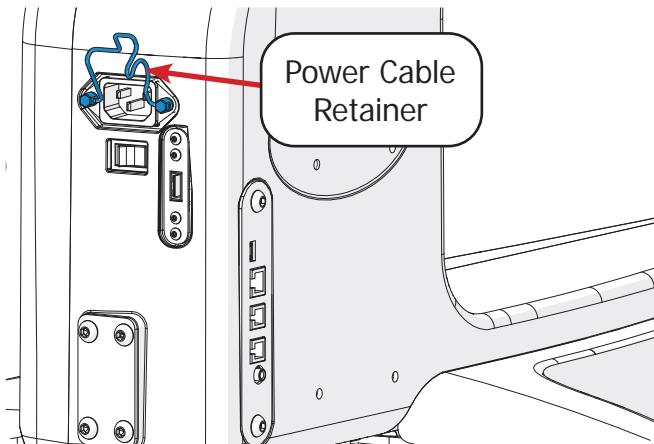

- 2 Plug the **power cable** into the machine.

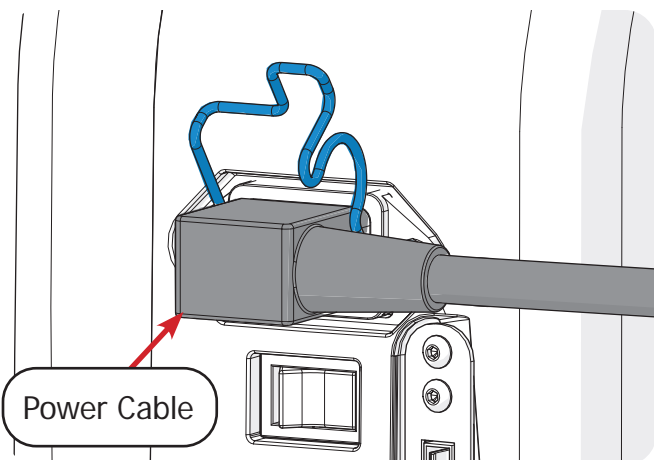

- 3 Press the power cable retainer down firmly until it grasps the power cable.

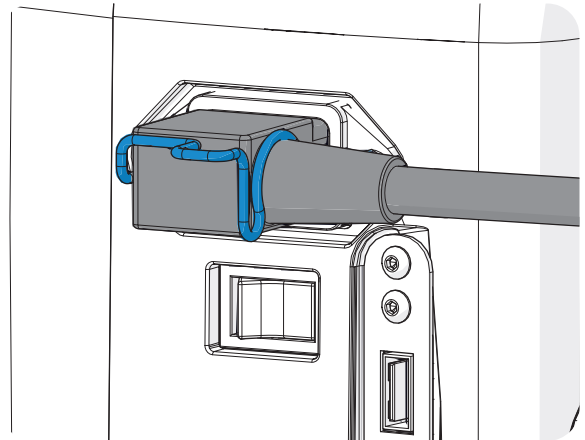

- 4 Press the right side of the **power switch** to turn the machine on.

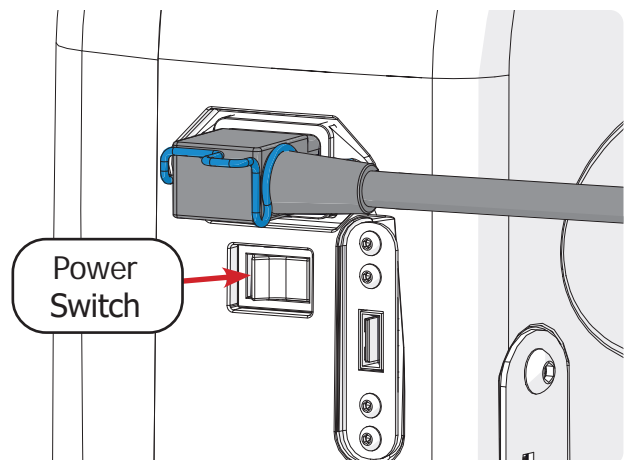



# Preparing to Quilt

This section of the manual covers choosing the settings for your machine, winding the bobbin, loading the bobbin case, and threading the machine.

<b>Choosing Machine Settings .....</b>	<b>page 27</b>
<b>Winding a Bobbin .....</b>	<b>page 29</b>
<b>Loading the Bobbin Case .....</b>	<b>page 31</b>
<b>Threading the Machine.....</b>	<b>page 33</b>
<b>Final Checklist .....</b>	<b>page 38</b>

## Choosing Machine Settings

To customize the settings for the handlebar controls, screen buttons, or warning icons, take the following steps:

- 1 Press the **Settings** icon at the bottom of the touch display.

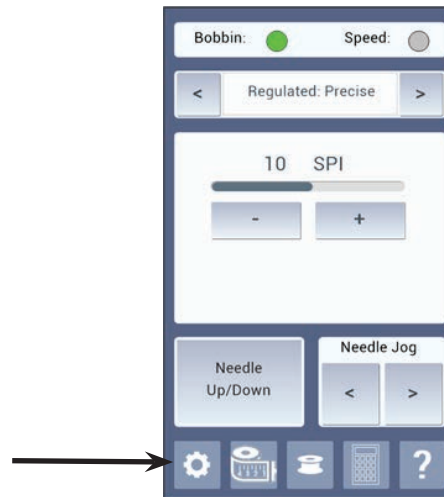

The Settings menu opens.

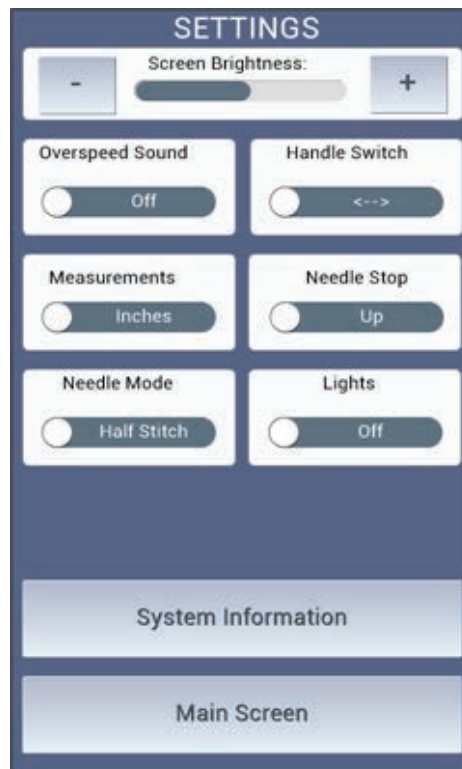

## Preparing to Quilt

### Choosing Machine Settings (Continued)

**Note:** While in the Settings menu, the System Information screen, or the Help menu, only two of the handlebar buttons have a function:

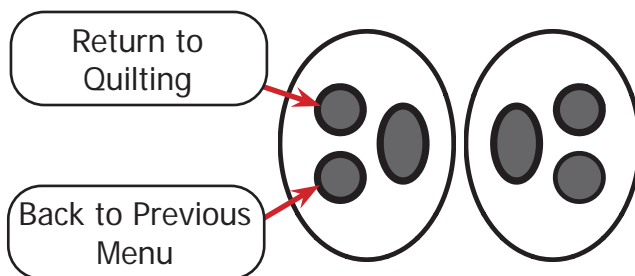

#### 2 Choose desired settings:

- **Screen Brightness:** Use this option to adjust the brightness of the display.

 Decrease screen brightness.

 Increase screen brightness.

- **Overspeed Sound:** The overspeed alarm can be muted so that there is no beeping when the machine is moved more quickly than the regulated stitching can manage.
- **Handle Switch:** Select between handlebar controls for right or left-handed quilters.
- **Measurements:** Choose to display machine stitch length in stitches per centimeter or stitches per inch.
- **Needle Stop:** Choose whether the needle will default to the “up” or “down” position when stitching is inactive.
- **Needle Mode:** Choose whether the stitch button on the quilting mode screens and handlebar controls will create a half-stitch or toggle the needle between the up or down positions.
- **Lights:** Press to turn the lamp above the needle area on or off.

#### 3 Press the **System** button to access the System Information screen. This displays the firmware versions for your machine (see page 71) as well as the stitch count and run-time (see page 54).

#### 4 To return to quilting, press the **Main Screen** button or the “**Return to Quilting**” button on the handlebar controls.

## Winding a Bobbin

For information on adjusting the bobbin fill levels, see page 62.

### Parts & Tools Needed:

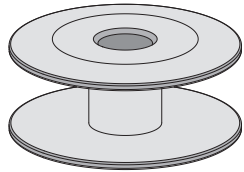

Bobbin (Class M)

### Instructions

Your machine comes with two bobbins pre-wound with 50 weight cotton thread. An empty M-class bobbin has also been provided. It's important to choose bobbin thread that is similar in type and quality as the top thread. For more information on choosing thread, see "Choosing Your Thread" on page 85.

**Note:** This machine uses cone-style thread. Unless you have the spool accessory, please use only thread cones for this machine.

The following diagram outlines the path the thread (shown in blue) must take to wind the bobbin.

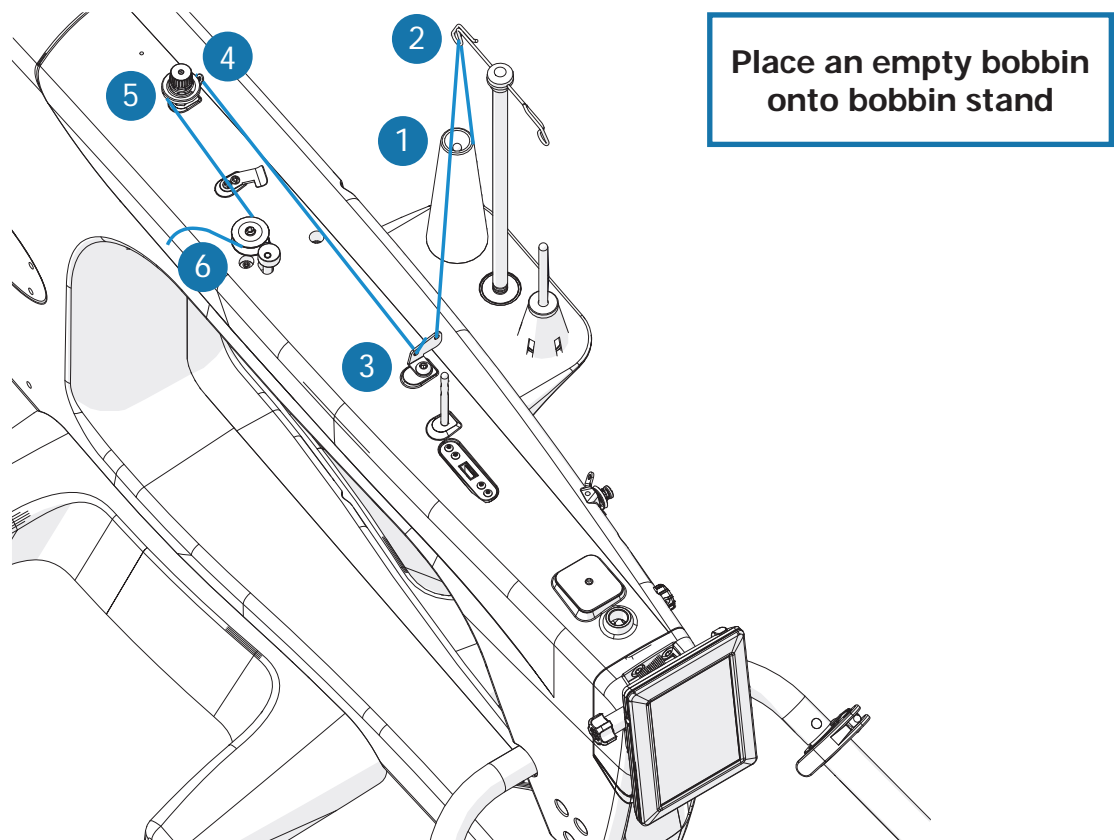

Place an empty bobbin onto bobbin stand

- 1 Thread Stand
- 2 Guide Loops

- 3 Bobbin Thread Guide
- 4 Tensioner Thread Guide

- 5 Bobbin Thread Tensioner
- 6 Bobbin Stand with Bobbin

# Preparing to Quilt

## Winding a Bobbin (Continued)

- 1 Run the thread through the **thread mast guide loop** directly above the thread cone.

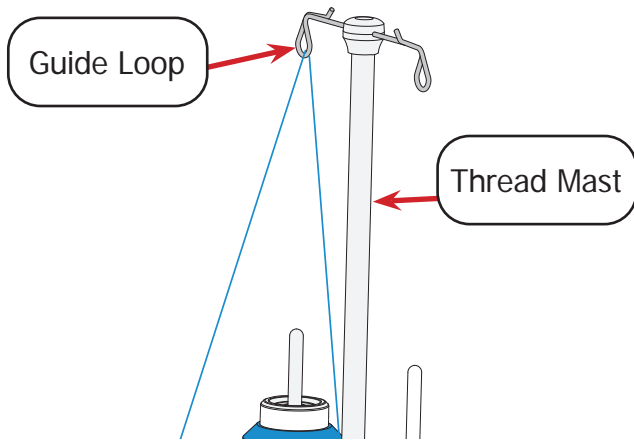

- 2 Feed the thread through the front of the first hole (closest to the thread cone) on the **bobbin thread guide**. Then wrap it back over and pass through the front of the second hole.

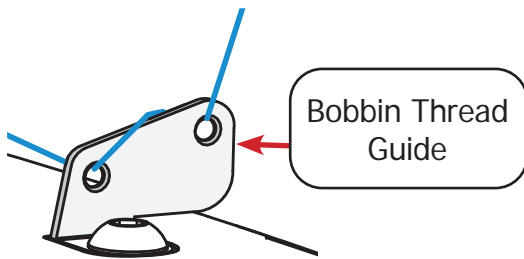

- 3 Pull the thread through the hole in the **tensioner thread guide** and then around the back of the **bobbin thread tensioner**, between the two discs.

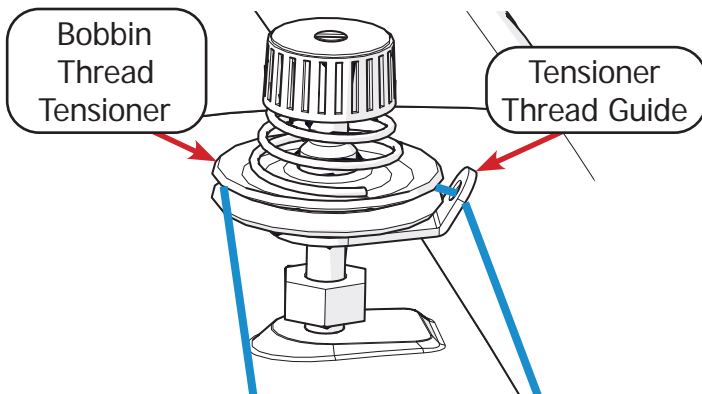

- 4 Tightly wrap the thread clockwise around the bobbin a few times to hold the thread in place. Push the **bobbin cam** toward the bobbin to start winding.

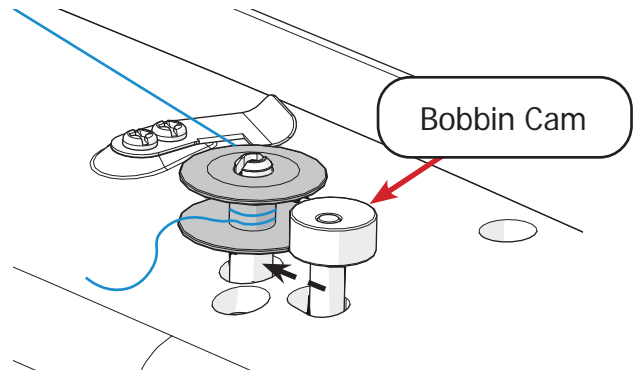

- 5 Winding stops automatically when the bobbin is full. Cut the thread with the **thread cutter** near the bobbin cam.

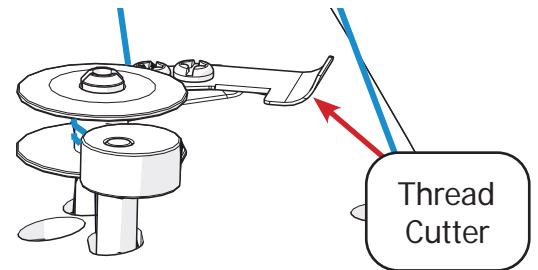

The bobbin thread should appear neat and smooth.

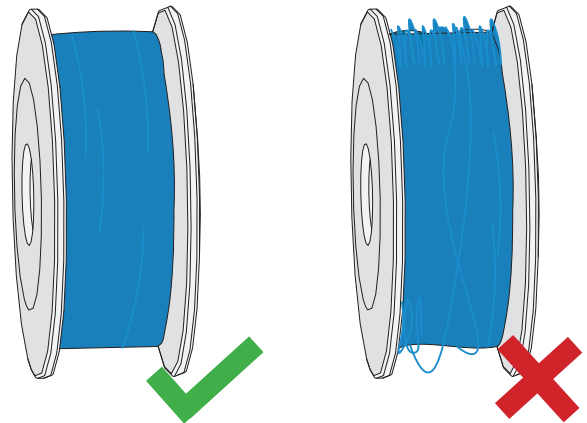

**Note:** Bobbin fill levels can be adjusted (see page 62).

## Loading the Bobbin Case

Take the following steps to insert the wound bobbin into the bobbin case and place it in the machine:

- 1 Check that the needle is up. If needed, rotate the **hand wheel** to raise the needle.

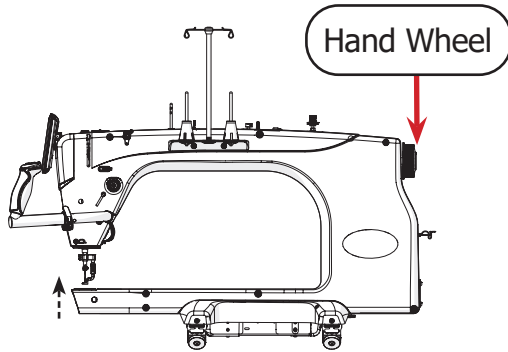

- 2 Press **Settings** on the display to go to the Settings menu. This prevents accidental stitching.

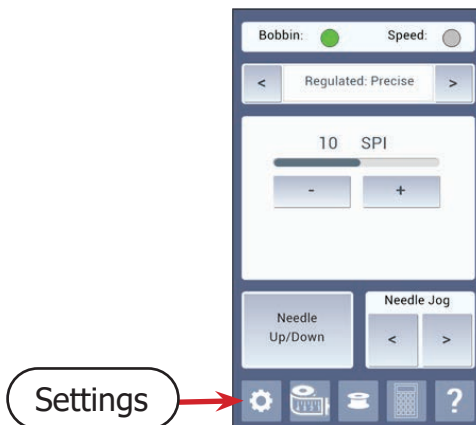

- 3 Pull on the bobbin case **release lever** to remove the bobbin case from the hook assembly.

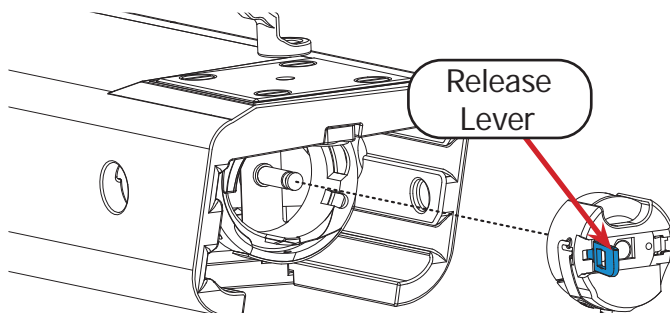

- 4 Place the wound bobbin into the **bobbin case**. Note the direction that the thread is coming off the bobbin in relation to the case.

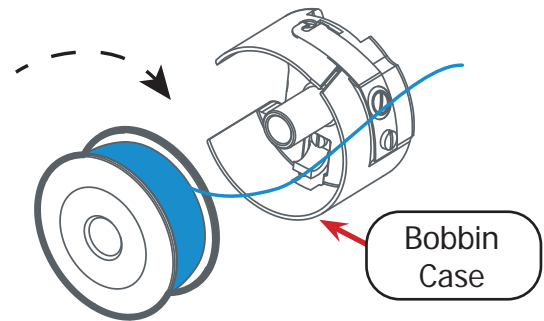

- 5 Slip a few inches of thread through the **slot** and out of the **hole**.

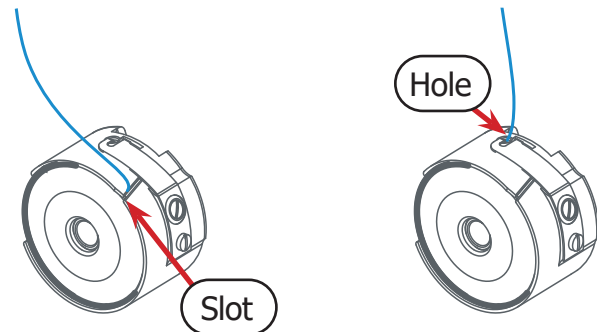

**Note:** If the bobbin is wound correctly it will turn clockwise when the thread is pulled.

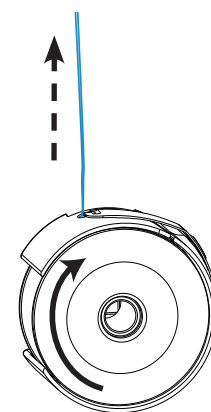

## Preparing to Quilt

### Loading the Bobbin Case (Continued)

- 6 Test the tension of the bobbin case every time bobbin thread is changed; bobbin tension is the foundation for correct thread tension.
- a. Place the bobbin case flat on its side, on your palm.

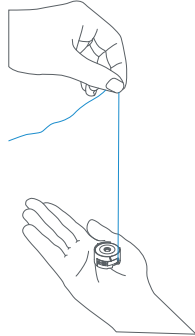

- b. Pull up on the thread. The thread should run freely and the bobbin case should rise into a vertical position without lifting off your hand.

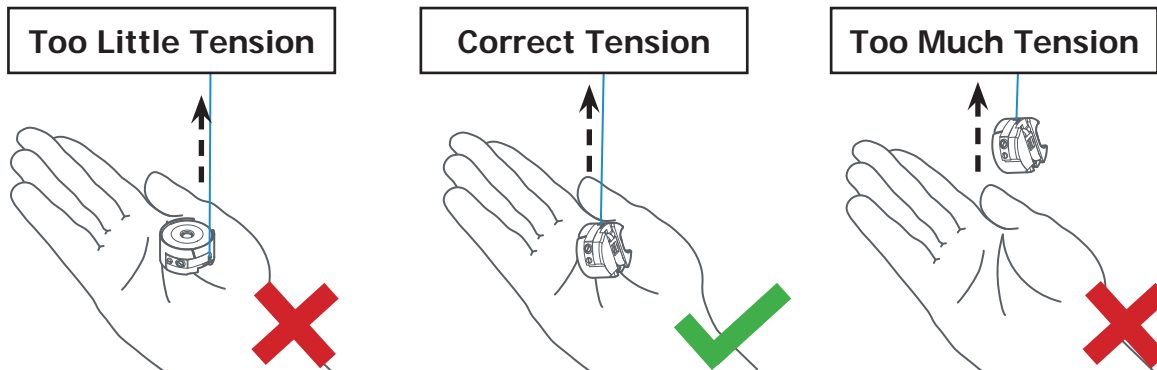

- If the case remains on its side, there is too little tension. Turn the **large screw** clockwise.
- If the case lifts into the air, there is too much tension. Turn the **large screw** counter-clockwise.

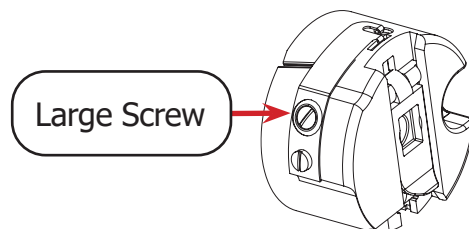

- 7 Place the bobbin case inside the machine with the **lever** (shown in blue) at the 3 o'clock position. It should click into place. Do not pull on the lever while inserting the bobbin case.

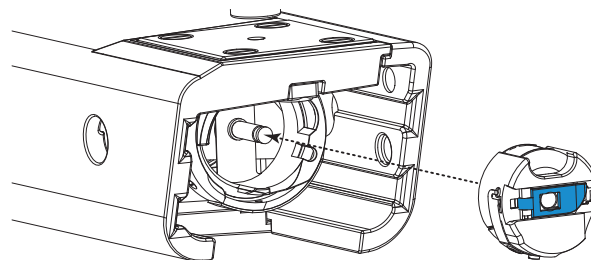



## Threading the Machine

Before threading the machine, make sure you've selected quality thread for your project. Choosing the right thread for the machine can prevent the thread from breaking or tangling up under the needle plate. For more information on choosing thread, see page 85. Note the following:

- This machine uses cone-style thread, not thread from a spool. Do not use spool thread unless the spool accessory (not included in this kit) has been installed.



- Choose thread that is strong enough to pass the yank test (shown below), and re-test thread as it ages. Thread strength can diminish over time.

- Hold the cone in one hand and the end of thread in the other.

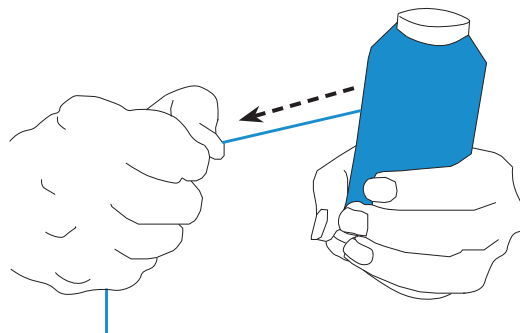

- Tug on the thread. If the thread snaps easily, it may be too brittle to use for quilting.

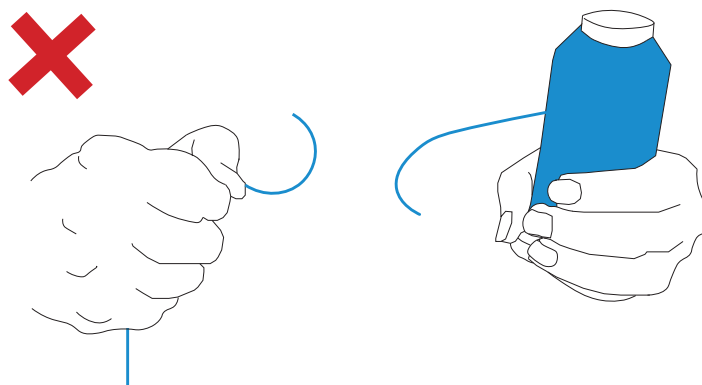

## Preparing to Quilt

### Threading the Machine (Continued)

The following diagram outlines the path the thread (shown in blue) must take through the machine.

- 1 Thread Cone
- 2 Thread Mast Guide Loop
- 3 Thread Guide Rod
- 4 Small Thread Tensioner
- 5 Right Thread Guide
- 6 Large Thread Tensioner
- 7 Check Spring
- 8 Thread Guide
- 9 Take-up Lever
- 10 Bottom Thread Guide
- 11 Needle Bar Eyelet
- 12 Eye of Needle

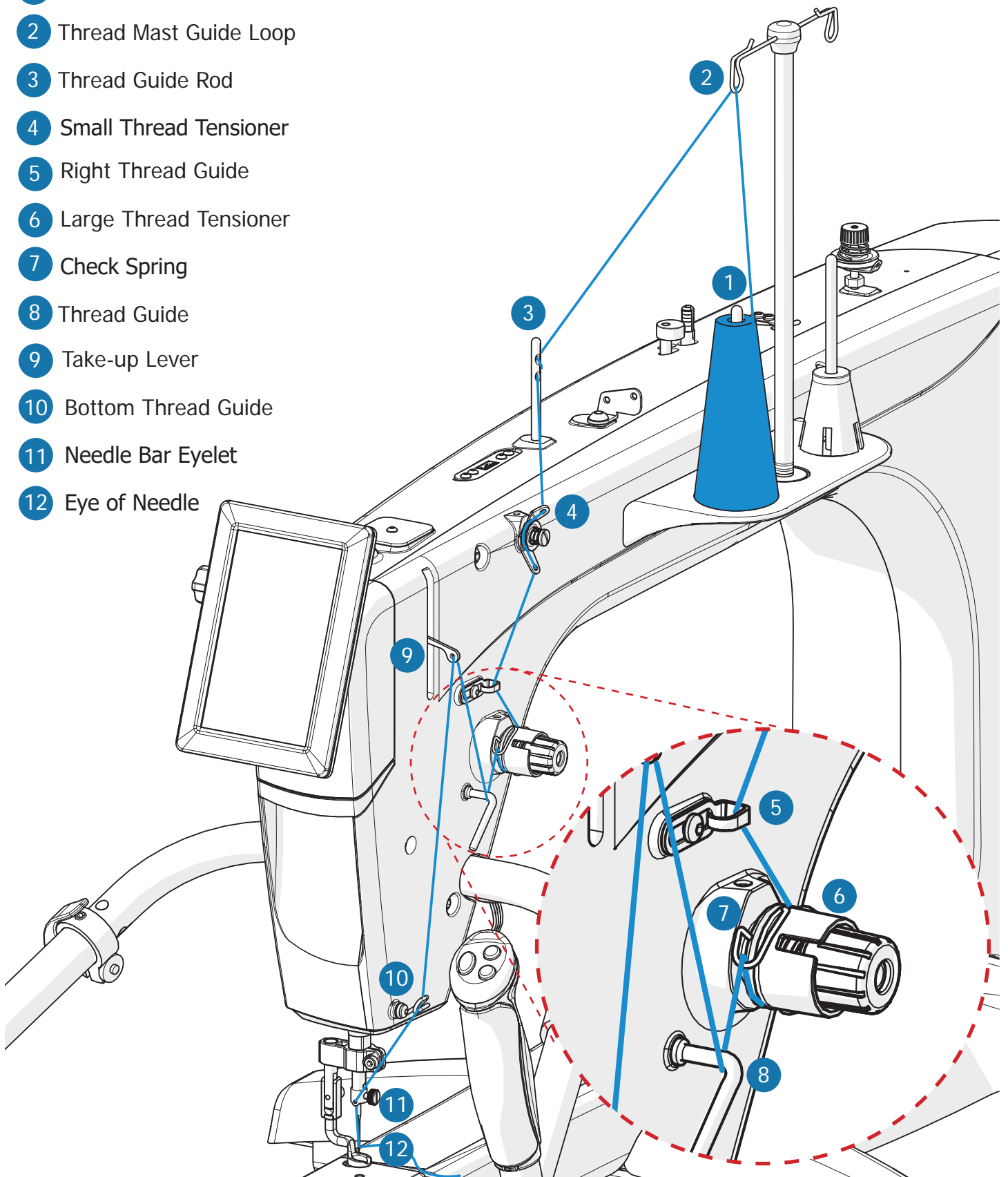

Threading the Machine (Continued)

- 1 Rotate the **hand wheel** at the rear of the machine to raise the needle to the top position.

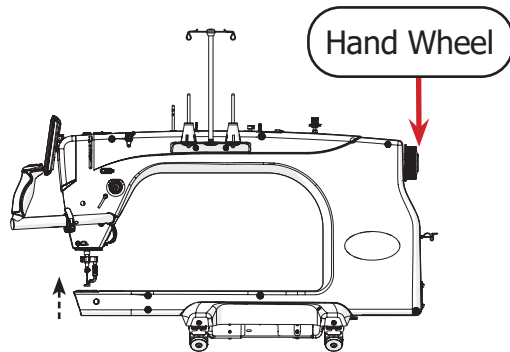

- 2 Press **Settings** on the display to go to the Settings menu. This prevents accidental stitching.



- 3 Place the **thread cone** on the cone-style **thread stand** toward the front of the machine.

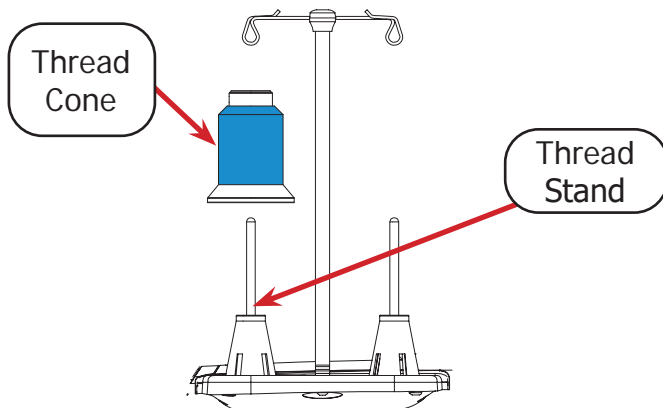

- 4 Pull the thread straight up, through the **thread mast guide loop** above the thread stand.

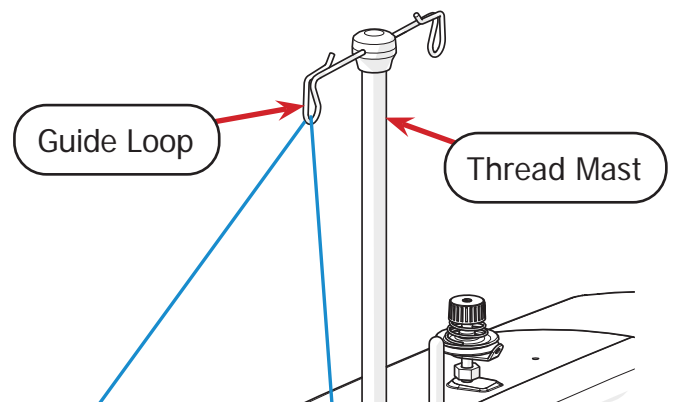

- 5 Feed the thread through the top hole of the **thread guide rod**. Wrap the thread around to the back of the guide and insert through the bottom hole.

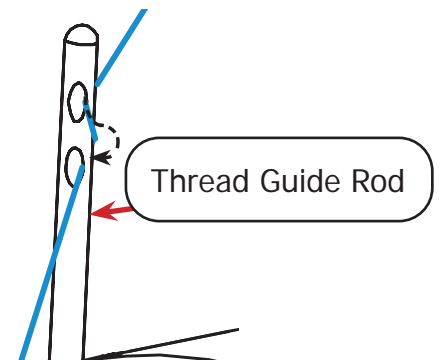

- 6 Run the thread through the top hole on the **small thread tensioner**. Then slip the thread between the two discs, and through the bottom hole of the small thread tensioner.

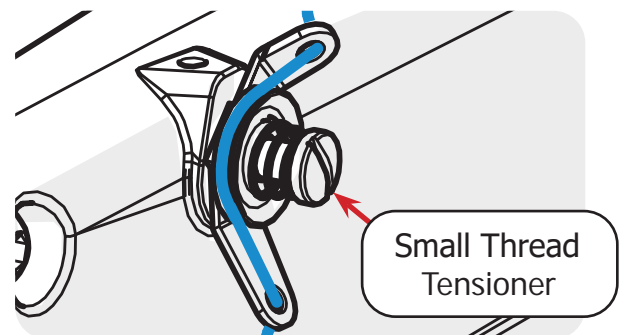

# Preparing to Quilt

## Threading the Machine (Continued)

- 7 Feed the thread through the thread guide above the large thread tensioner.

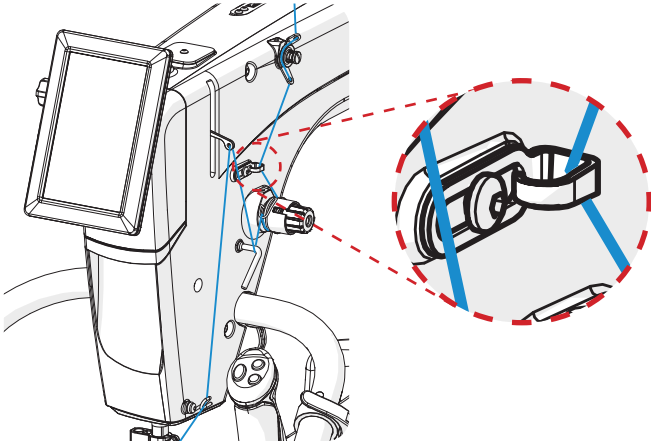

- 8 Pull the thread around the **large thread tensioner**, between the tension discs.

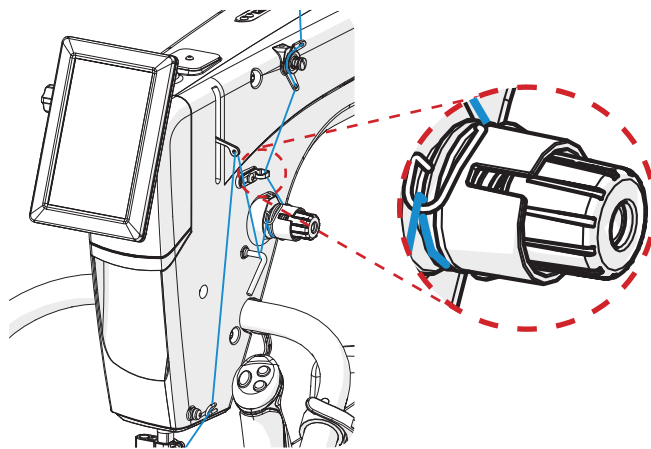

- 9 Wrap the thread over the **check spring**.

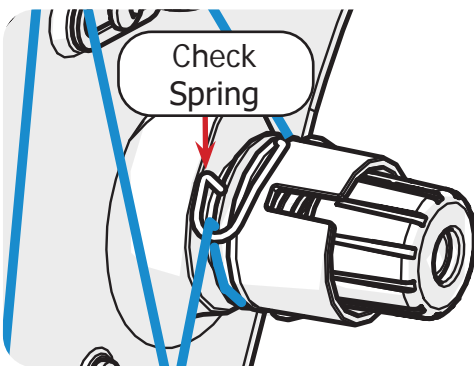

- 10 Next, pass the thread down and around the **thread guide** next to the large thread tensioner.

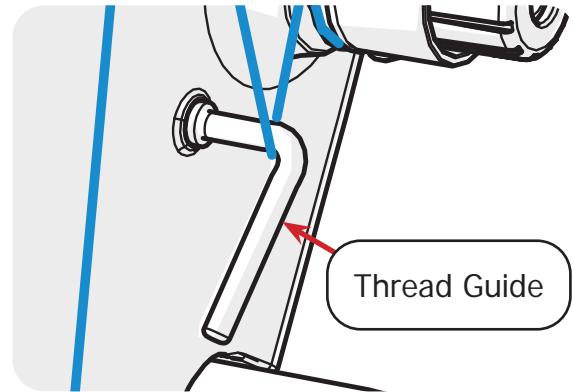

- 11 Pull the thread through the hole in the **take-up lever**.

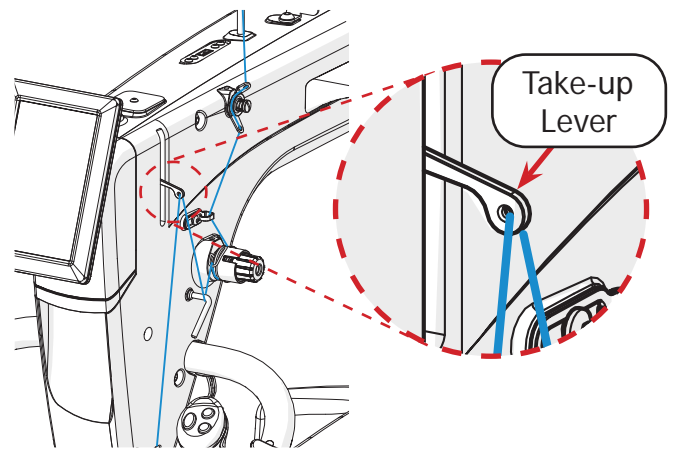

- 12 Then pass the thread down through the **bottom thread guide** on the way to the needle.

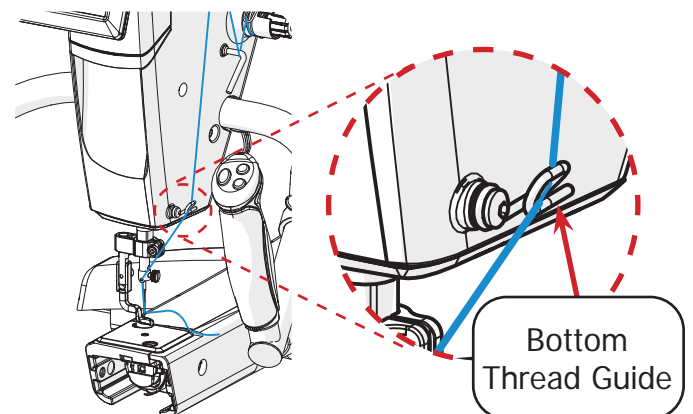

## Threading the Machine (Continued)

- 13 Now pass the thread through the front of the **needle bar eyelet**, located above the needle. Thread the **eye of the needle** from front to back.

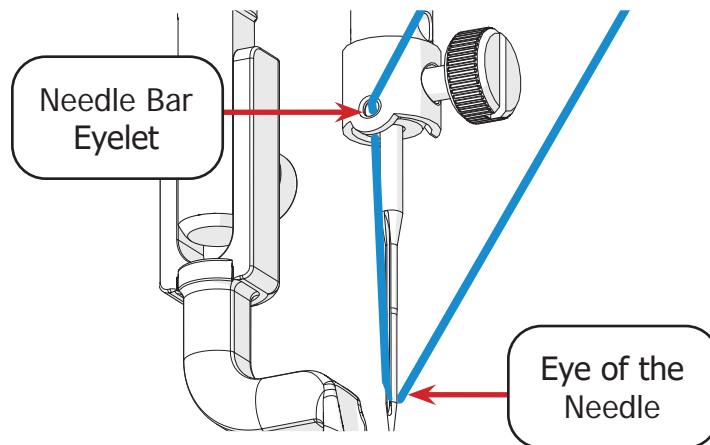

- 14 Cut the excess thread with the built-in **thread cutter**.

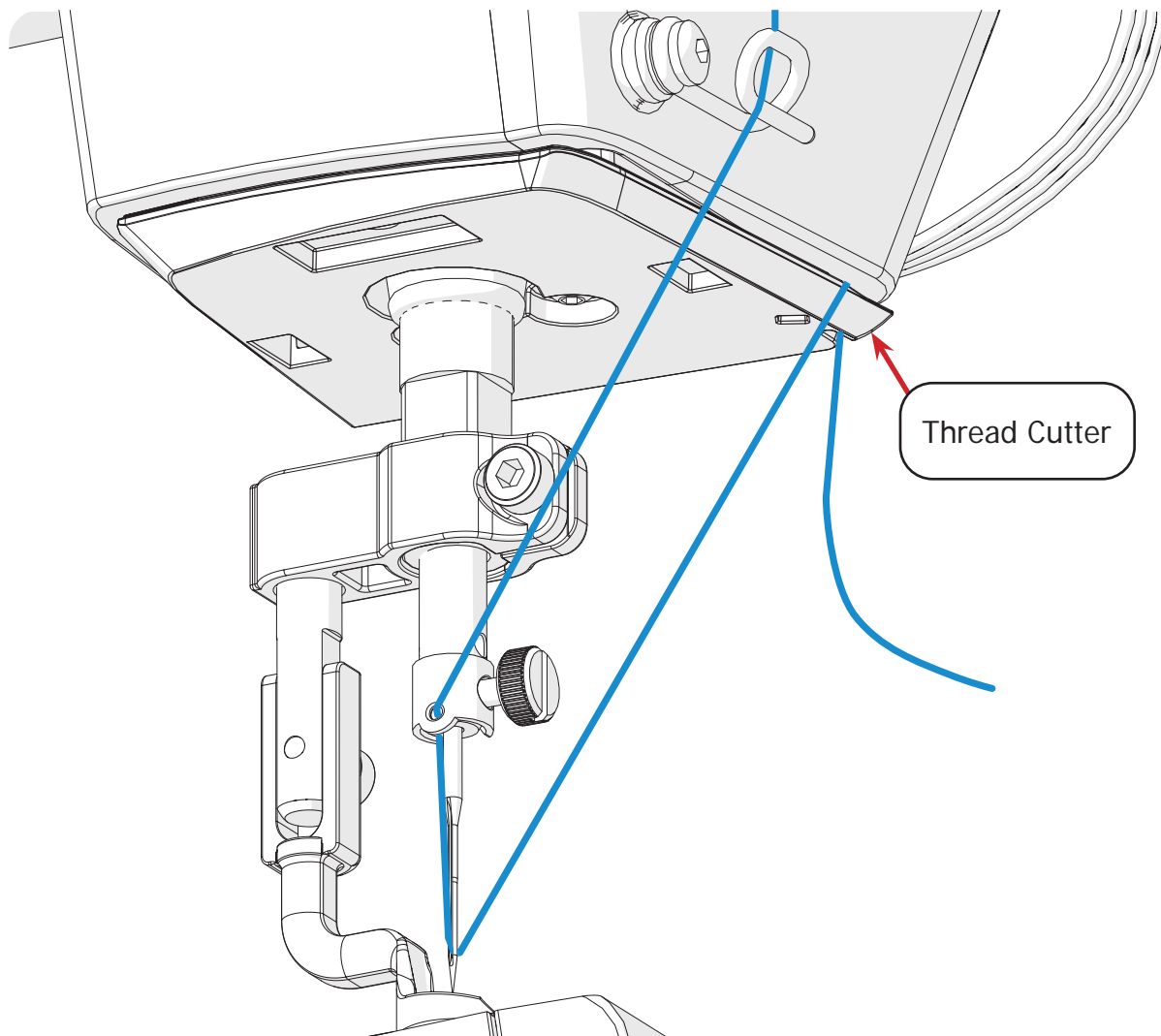

Before you begin quilting, make sure that:

- The bobbin is wound and installed in the machine.
- The needle is straight, and held firmly to the needle bar.
- The power cord is connected to the machine and power outlet.
- The quilting area is clear of any materials that are not needed for quilting.

# Quilting

Now that the machine is set up, it's time to start quilting! This section of the manual describes handlebar control, using the four quilting modes, and tensioning the thread.

<b>Using the Handlebar Controls .....</b>	<b>page 40</b>
<b>Using the Precise Quilting Mode .....</b>	<b>page 41</b>
<b>Using the Cruise Quilting Mode .....</b>	<b>page 43</b>
<b>Using the Baste Quilting Mode .....</b>	<b>page 45</b>
<b>Using the Manual Quilting Mode .....</b>	<b>page 47</b>
<b>Estimating Bobbin Fill Levels.....</b>	<b>page 49</b>
<b>Adjusting Thread Tension.....</b>	<b>page 50</b>
<b>Taking Measurements .....</b>	<b>page 52</b>
<b>Making Calculations .....</b>	<b>page 53</b>
<b>Tracking Stitch Count &amp; Run Time.....</b>	<b>page 54</b>

**Tip:** While familiarizing yourself with the controls and display of your quilting machine, it's a good time to test out new quilting materials and practice stitching. Test your thread tension while using the different quilting modes available on the machine.

## Using the Handlebar Controls

When first powered up, the machine is in regulated precise quilting mode (see page 41) and can start quilting right away. Please take a moment to review the handlebar controls. These controls are used when quilting. While in the Settings menu, some buttons have a different purpose or do not function (see "Choosing Machine Settings" on page 27 for details).

**Note:** Left-handed quilters may prefer to reverse these buttons. This can be done in the Settings menu (see "Choosing Machine Settings" on page 27).

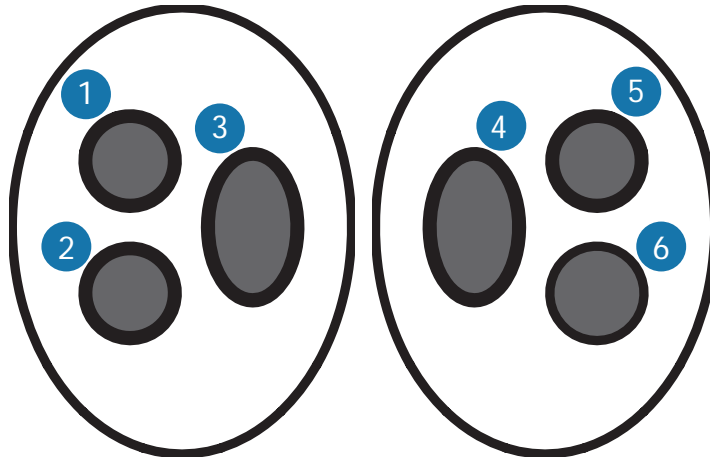

- 1 Change Quilting mode:** Press to cycle through the quilting modes: regulated precise, regulated cruise, baste, and manual.
- 2 Settings:** This button opens the Settings menu.
- 3 Single Full Stitch or Needle Up/Down**
  - Press to create a single full stitch or to toggle the needle between the up and down positions, based upon settings (see "Choosing Machine Settings" on page 27 for details).
- 4 Start/Stop Quilting:** Press to start or stop stitching.
- 5 Increase:** This button increases the number, size, or speed of the stitching, depending upon the quilting mode. For example, in precise quilting mode, this button will increase the number of stitches the machine makes in an inch (SPI) or in a centimeter (SPC).
- 6 Decrease:** This button will decrease the number, size, or speed of the stitching depending upon the quilting mode.



## Using the Precise Quilting Mode

The machine defaults to the regulated precise quilting mode when turned on. In this regulated quilting mode, the machine maintains the length of the stitch despite the speed and direction of the quilter's movements. If the quilter stops moving, the machine stops stitching.

To switch to a different quilting mode, press the **next quilting mode** button.

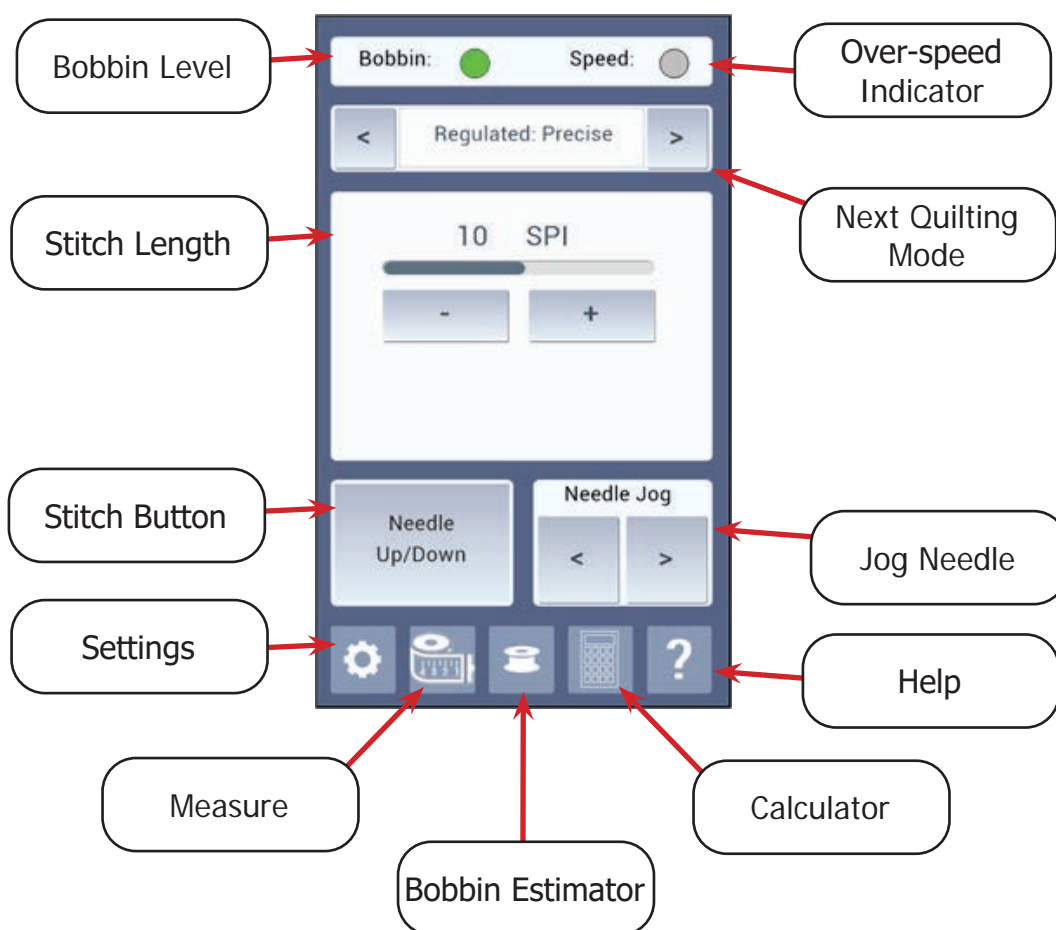

To quilt in the regulated precise quilting mode, take the following steps:

- 1 Confirm that the **stitch length**, measured in stitches per inch, is the desired length. Note: This can be changed to stitches per centimeter in the **Settings** menu (see page 27).

 Press to reduce the number of stitches per inch and increase stitch length.

 Press to increase the number of stitches per inch, which decreases stitch length.

- 2 Check the **stitch button** icon. When stitching is inactive, pressing this button or the stitch button on the handlebars will create a single stitch, or toggle the needle to the up or down position, depending on settings. To switch the type of stitch created, go to the Settings menu (see page 27).

# Quilting

## Using the Precise Quilting Mode (Continued)

- 3 Position the quilting machine over the quilt. If needed, use the **needle jog** buttons to move the needle closer or further from the fabric in small increments to help place your first stitch.

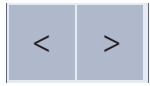

Press to move the needle up or down in small increments.

- 4 The **over-speed indicator** shows in green when stitching is active, and in gray when it is not. Press the start/stop quilting button on the handlebar to begin (activate) stitching. Move the machine across the quilt to place stitches. Keep the pace slow and even; moving too quickly can prevent stitch regulation. If this happens, a beeping alarm will sound and the **over-speed indicator** on the display will turn red. Alarm can be muted in the Settings menu (see page 27).

**Note:** While stitching is active, the **stitch button** on both the display and handlebar controls are disabled.

- 5 The **bobbin level** indicator can be used to estimate the amount of thread remaining on a bobbin. For instructions on using the **bobbin estimator**, see page 49.
  - When the icon is green, the bobbin is estimated to be between 21% and 100% full.
  - When the icon is yellow, the bobbin is estimated to be between 11% and 20% full.
  - When the icon is red, the bobbin is estimated to be at under 10%.

- 6 You may find that you need to take measurements or do quick calculations while you quilt. Press the **measure** or **calculator icon** to access these functions.

- 7 To deactivate stitching, press the start/stop quilting button on the handlebars. The needle will move into the needle stop position indicated in the Settings menu (see page 27).

**Tip:** For a refresher on using the handlebar controls, or for achieving quality stitching, tap on the **Help** icon.

## Using the Cruise Quilting Mode

In cruise mode, the quilting machine maintains the length of the stitch despite the speed and direction of the quilter's movements. However, the machine will continue to stitch in place (at the minimum speed) if the quilter stops moving the machine.

To switch to a different quilting mode, press the **next quilting mode** button.

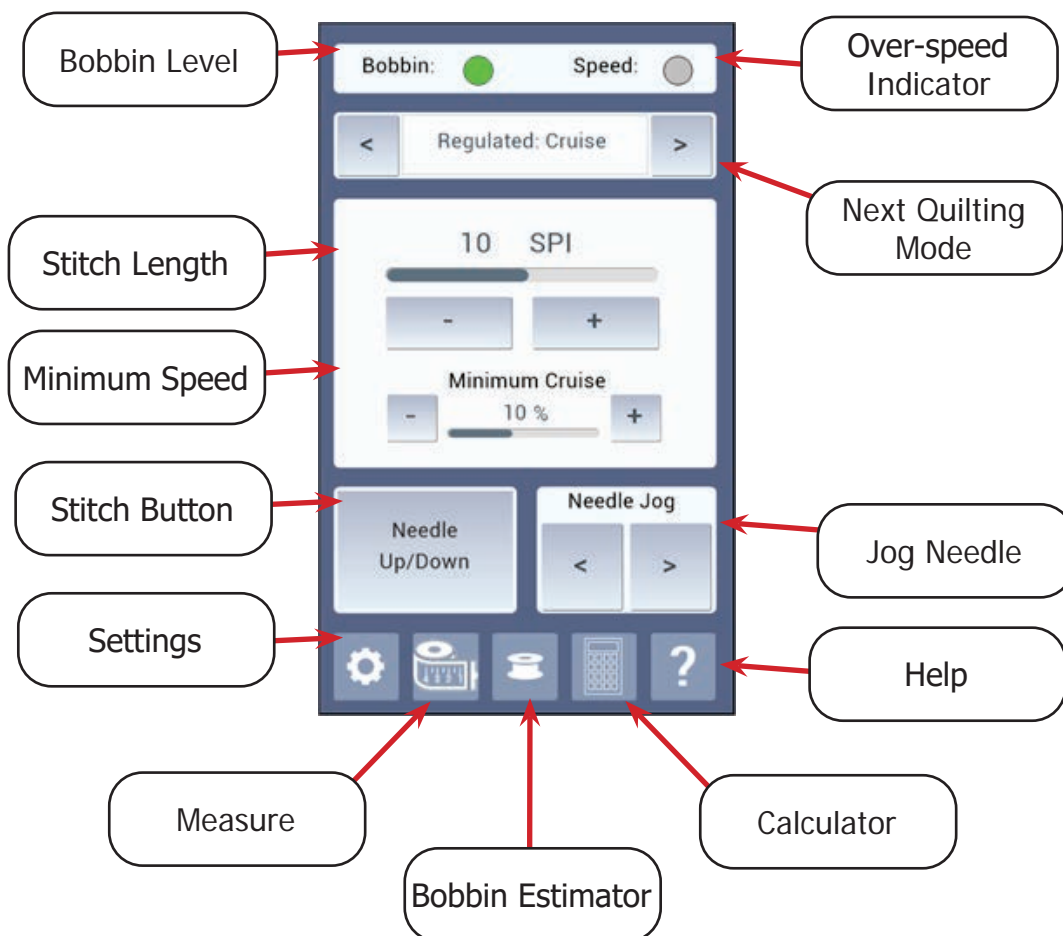

To quilt in the regulated cruise quilting mode, take the following steps:

- 1 Confirm that the **stitch length**, measured in stitches per inch, is the desired length. Note: This can be changed to stitches per centimeter in the **Settings** menu (see page 27).

**-** Press to reduce the number of stitches per inch and increase stitch length.

**+** Press to increase the number of stitches per inch, which decreases stitch length.

- 2 Determine the **minimum speed** the machine will stitch at when stitching is active but the machine is not being moved. This can be set from 5% to 25% of the machine's top speed.

**-** Decreases the minimum speed.

**+** Increases the minimum speed.

## Using the Cruise Quilting Mode (Continued)

- 3 Check the **stitch button** icon. When stitching is inactive, pressing this button or the stitch button on the handlebars will create a single stitch, or toggle the needle to the up or down position, depending on settings. To switch the type of stitch created, go to the Settings menu (see page 27).
- 4 Position the quilting machine over the quilt. If needed, use the **needle jog** buttons to move the needle closer or further from the fabric in small increments to help place your first stitch.

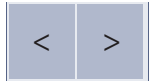

Press to move the needle up or down in small increments.

- 5 The **over-speed indicator** shows in green when stitching is active, and in gray when it is not. Press the start/stop quilting button on the handlebar to begin (activate) stitching. Move the machine across the quilt to place stitches. Keep the pace slow and even; moving too quickly can prevent stitch regulation. If this happens, a beeping alarm will sound and the **over-speed indicator** on the display will turn red. Alarm can be muted in the Settings menu (see page 27).

**Note:** While stitching is active, the **stitch button** on both the display and handlebar controls are disabled.

- 6 The **bobbin level** indicator can be used to estimate the amount of thread remaining on a bobbin. For instructions on using the **bobbin estimator**, see page 49.
  - When the icon is green, the bobbin is estimated to be between 21% and 100% full.
  - When the icon is yellow, the bobbin is estimated to be between 11% and 20% full.
  - When the icon is red, the bobbin is estimated to be at under 10%.

- 7 You may find that you need to take measurements or do quick calculations while you quilt. Press the **measure** or **calculator icon** to access these functions.

- 8 To deactivate stitching, press the start/stop quilting button on the handlebars. The needle will move into the **needle stop position** indicated in the Settings menu (see page 27).

**Tip:** For a refresher on using the handlebar controls, or for achieving quality stitching, tap on the **Help** icon.

## Using the Baste Quilting Mode

Use the basting mode to create loose, temporary stitches to hold layers of fabric together while quilting.

To switch to a different quilting mode, press the **next quilting mode** button.

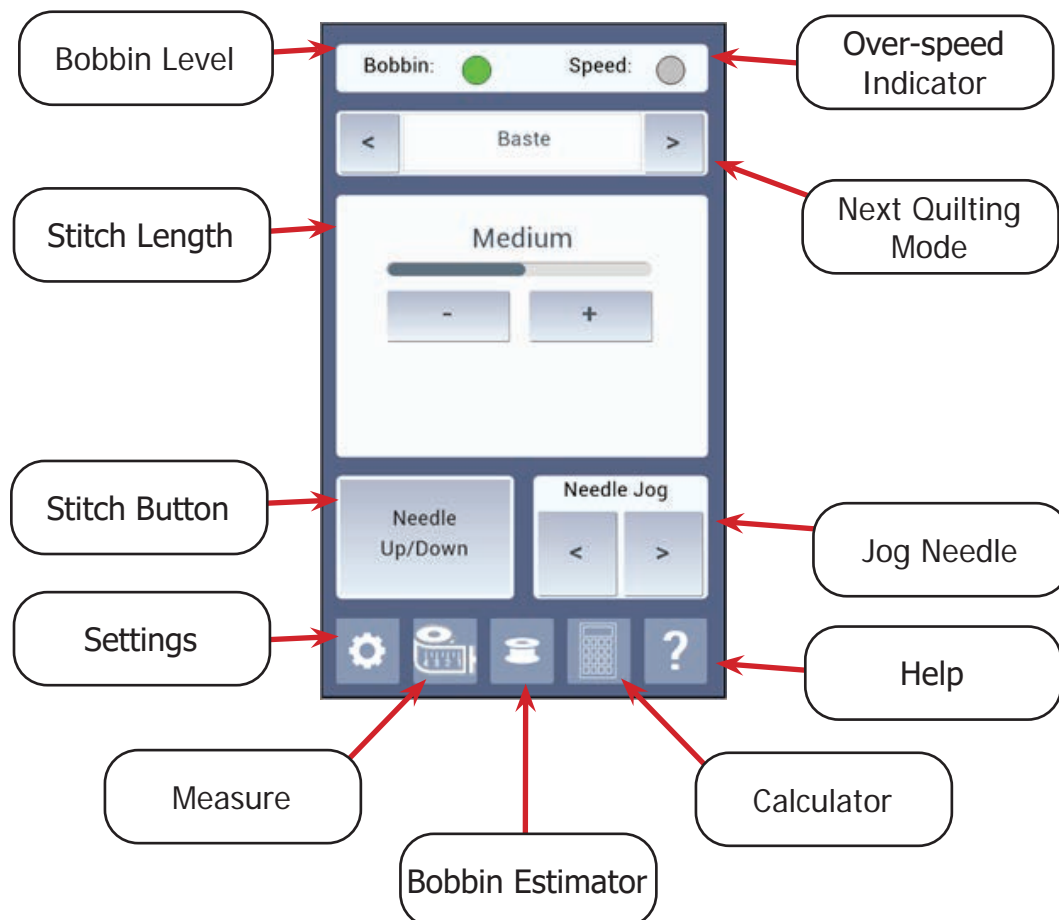

To quilt in the baste quilting mode, take the following steps:

- 1 Confirm that the **stitch length** is the desired length (small, medium, or large).
  - Press to reduce stitch length.
  - + Press to increase stitch length.
- 2 Check the **stitch button** icon. When stitching is inactive, pressing this button or the stitch button on the handlebars will create a single stitch, or toggle the needle to the up or down position, depending on settings. To switch the type of stitch created, go to the Settings menu (see page 27).
- 3 Position the quilting machine over the quilt. If needed, use the **needle jog** buttons to move the needle closer or further from the fabric in small increments to help place your first stitch.

< > Press to move the needle up or down in small increments.

## Using the Baste Quilting Mode (Continued)

- 4 The **over-speed indicator** shows in green when stitching is active, and in gray when it is not. Press the start/stop quilting button on the handlebar to begin (activate) stitching. Move the machine across the quilt to place stitches. Keep the pace slow and even; moving too quickly can prevent stitch regulation. If this happens, a beeping alarm will sound and the **over-speed indicator** on the display will turn red. Alarm can be muted in the Settings menu (see page 27).

**Note:** While stitching is active, the **stitch button** on both the display and handlebar controls are disabled.

- 5 The **bobbin level** indicator can be used to estimate the amount of thread remaining on a bobbin. For instructions on using the **bobbin estimator**, see page 49.
  - When the icon is green, the bobbin is estimated to be between 21% and 100% full.
  - When the icon is yellow, the bobbin is estimated to be between 11% and 20% full.
  - When the icon is red, the bobbin is estimated to be at under 10%.

- 6 You may find that you need to take measurements or do quick calculations while you quilt. Press the **measure** or **calculator icon** to access these functions.

- 7 To deactivate stitching, press the start/stop quilting button on the handlebars. The needle will move into the **needle stop position** indicated in the Settings menu (see page 27).

**Tip:** For a refresher on using the handlebar controls, or for achieving quality stitching, tap on the **Help** icon.



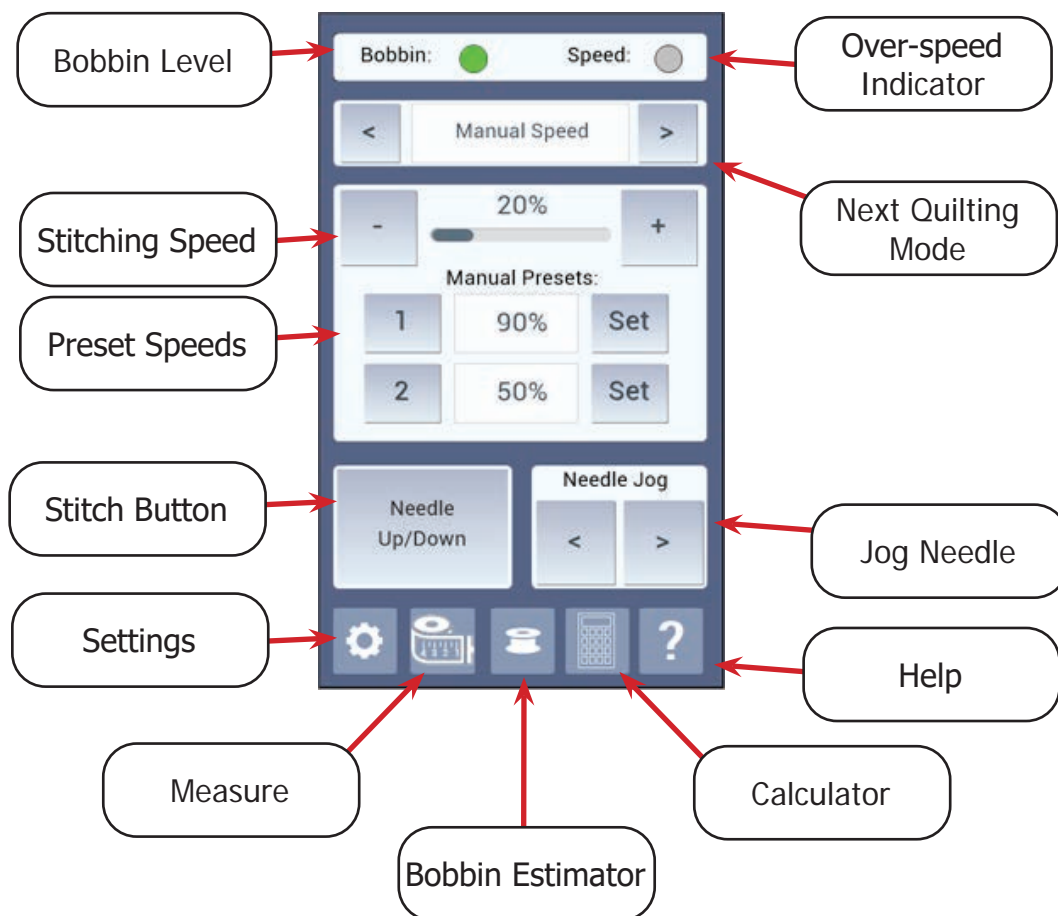

## Using the Manual Quilting Mode

In this quilting mode, the machine produces stitches at a certain speed. It's up to the quilter to move the machine the distance needed to get the desired stitch length. This mode is useful for small, continuous stippling patterns.

To switch to a different quilting mode, press the **next quilting mode** button.



To quilt in the manual quilting mode, take the following steps:

- 1 Confirm that the **stitch speed** is the desired speed. The stitching speed is displayed as a percentage of the maximum machine speed of 2600 stitches-per-minute.
  -  Press to reduce stitching speed.
  -  Press to increase stitching speed.
- 2 Establish your **speed presets**. Selecting a preset adjusts the machine's speed to the percent indicated.
  -  Press to update the preset speed to match the current stitching speed.
  -  Press the preset speed number to switch to that preset speed.
  - 

# Quilting

## Using the Manual Quilting Mode (Continued)

- 3 Check the **stitch button** icon. When stitching is inactive, pressing this button or the stitch button on the handlebars will create a single stitch, or toggle the needle to the up or down position, depending on settings. To switch the type of stitch created, go to the Settings menu (see page 27).
- 4 Position the quilting machine over the quilt. If needed, use the **needle jog** buttons to move the needle closer or further from the fabric in small increments to help place your first stitch.



Press to move the needle up or down in small increments.

- 5 The **over-speed indicator** shows in green when stitching is active, and in gray when it is not. Press the start/stop quilting button on the handlebar to activate stitching. Move the machine across the quilt to place stitches. Change the speed of your movements to match the stitching speed of the machine in order to create stitches of the desired length. Moving quickly will create longer stitches, while moving slowly will create shorter stitches.

**Note:** While stitching is active, the **stitch button** on both the display and handlebar controls are disabled.

- 6 The **bobbin level** indicator can be used to estimate the amount of thread remaining on a bobbin. For instructions on using the bobbin estimator, see page 49.
  - When the icon is green, the bobbin is estimated to be between 21% and 100% full.
  - When the icon is yellow, the bobbin is estimated to be between 11% and 20% full.
  - When the icon is red, the bobbin is estimated to be at under 10%.
- 7 You may find that you need to take measurements or do quick calculations while you quilt. Press the **measure** or **calculator icon** to access these functions.
- 8 To deactivate stitching, press the start/stop quilting button on the handlebars. The needle will move into the **needle stop position** indicated in the Settings menu (see page 27).

**Tip:** For a refresher on using the handlebar controls, or for achieving quality stitching, tap on the **Help** icon.



## Estimating Bobbin Fill Levels

### Bobbin Level Indicator:

Your machine is equipped with a bobbin-fill estimation tool that will help you gauge when it is time to refill the bobbin. The **bobbin level indicator** displays at the top left corner of each quilting mode screen.

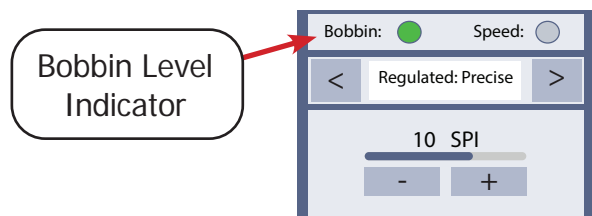

### Bobbin Indicator Color Code:

- **Green:** bobbin is between 21% and 100% full.
- **Yellow:** bobbin is between 11% and 20% full.
- **Red:** bobbin is estimated to be at 10% or under.

- **Note:** If the bobbin level indicator does not display, it has been disabled in the **Bobbin Estimate Settings** screen.

### Using the Bobbin Estimator:

The bobbin estimator calculates the likely amount of thread remaining on the bobbin. To achieve the closest estimate information must be accurately entered into the Bobbin Estimate Settings screen. Tap on the **bobbin estimator icon**  at the bottom of any quilting mode screen.

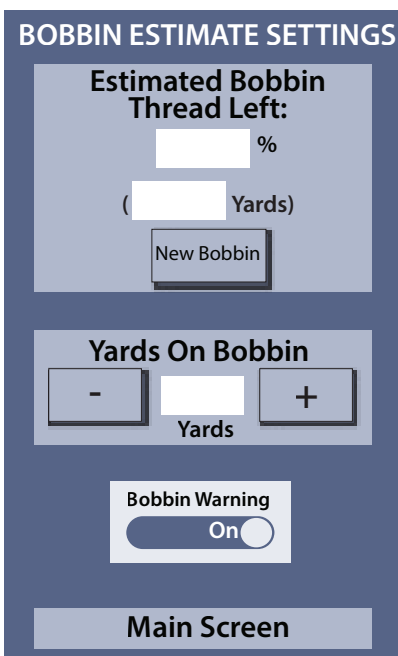

- 1 Press **New Bobbin** to start with a fresh bobbin.
- 2 Estimate the number of **yards on the bobbin**. As a starting reference, an M-class bobbin fully wound with 40 wt cotton thread is approximately 90 yards.
- 3 The estimated bobbin fill level is displayed both as a percentage and in yards.
- 4 To turn off the bobbin level indicator, press the **Bobbin Warning** option.
- 5 Press **Main Screen** to return to quilting.

## Adjusting Thread Tension

Proper thread tension prevents unwanted puckering, poorly-formed stitches, and malfunctions that can damage the fabric. Test your thread tension on extra materials before sewing on a project.

**Tip:** Bottom thread tension is addressed in “Loading the Bobbin Case” (see page 31).

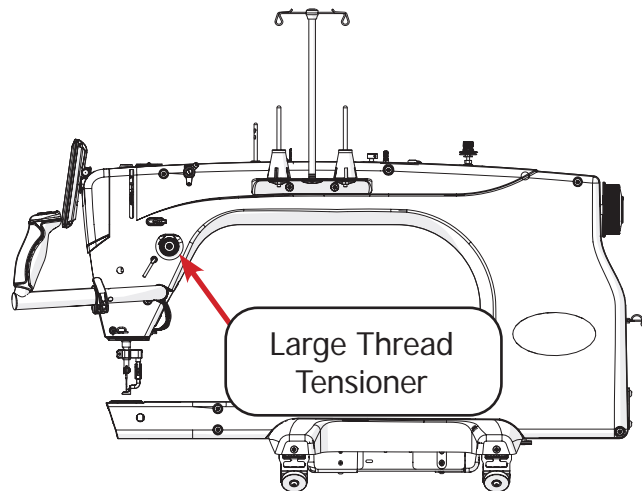

- 1 Loosen the **tension knob** on the **large thread tensioner** to set the tension to “1.” The bottom of the tension knob will line up with the number that the tension is set to.

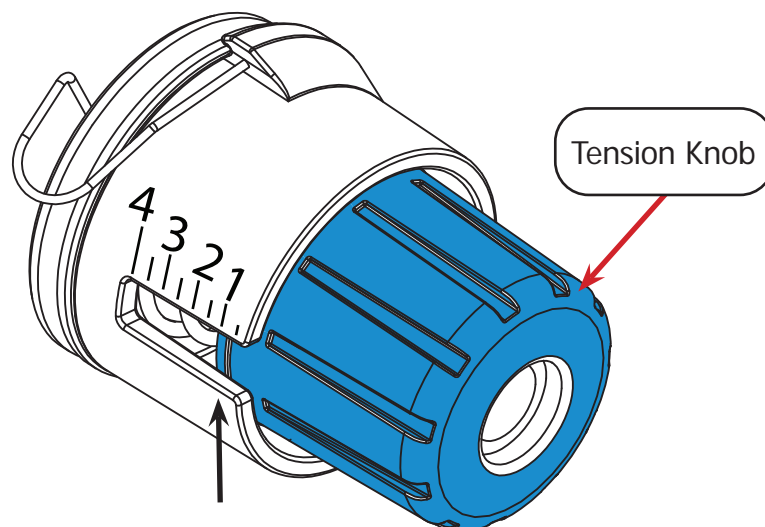

**Note:** Setting “1” is the lowest tension for your machine, and is an ideal starting place to find the correct top tension.

Adjusting Thread Tension (Continued)

- 2 Slowly increase the tension while stitching into scrap material. When the thread tension is balanced, the top and bottom thread (shown in blue and red) will knot in the middle of the fabric layers.

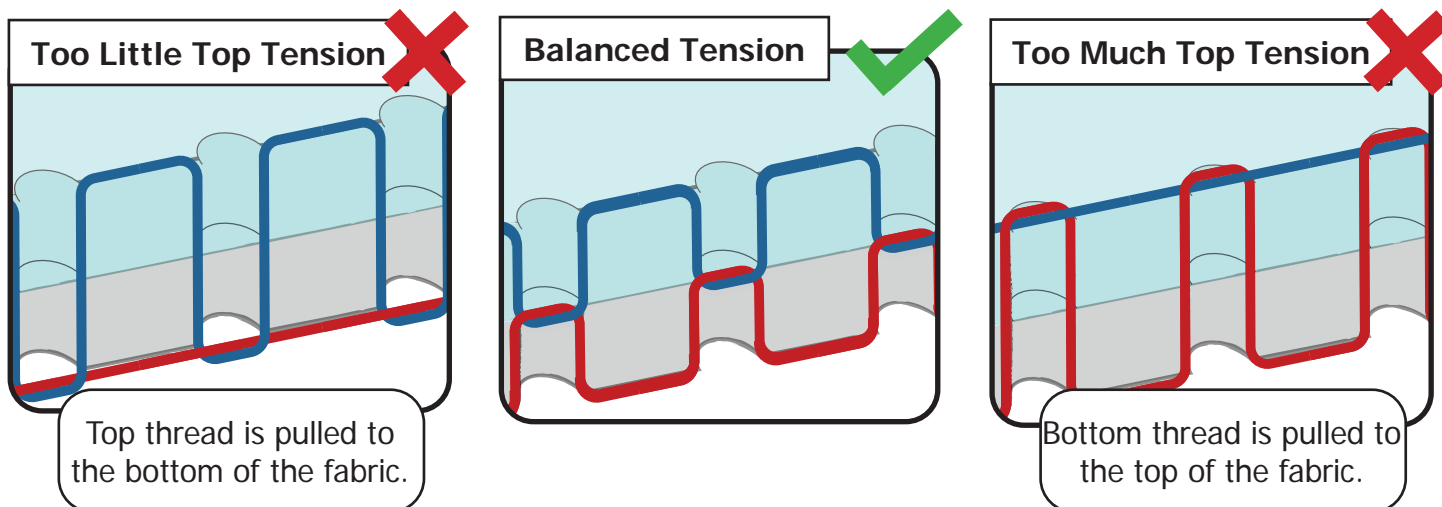

- If the **bobbin (bottom) thread** (shown in red) is pulled through the top layer of fabric, there is too much top tension. Loosen the tension by turning the large thread tensioner knob toward the setting "1."

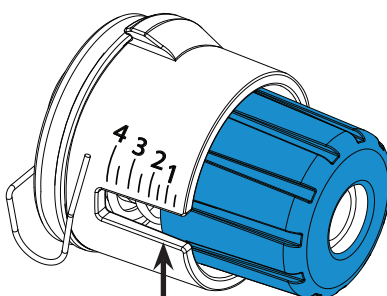

- If the **top thread** (shown in blue) is pulled down through the bottom layer of fabric, there is too little top tension. Increase the tension on the top by slowly turning the large thread tensioner knob toward setting "4." Stop turning the knob when desired tension is achieved.

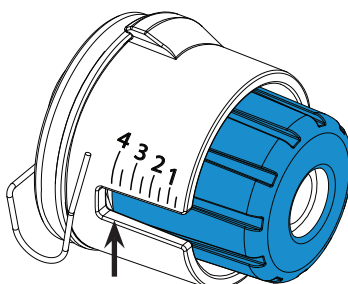

## Taking Measurements

Your machine can be used to take measurements across the surface of your quilt.

Press the **measure** icon at the bottom of any quilting screen to access the **Menu** screen.

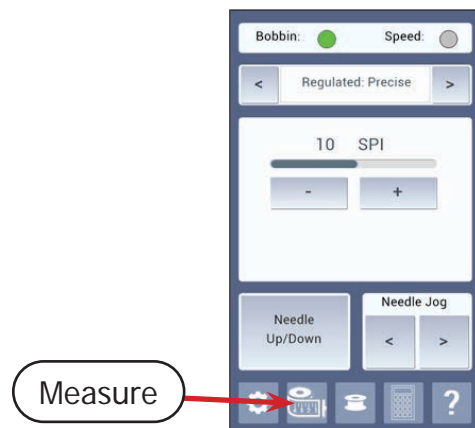

The Measurements screen will Display.

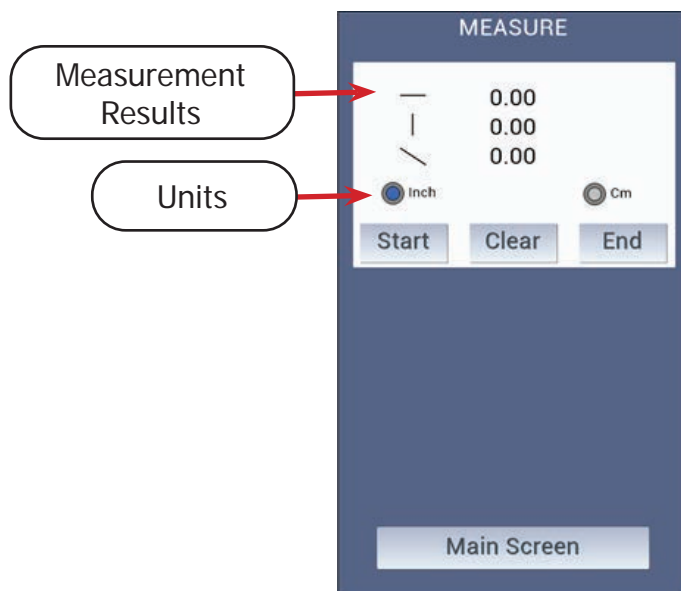

- 1 Choose to display your measurements in **inches** or **centimeters**.
- 2 Roll your machine to the starting point you'd like to measure from. Press **Start**. The start button will turn green when pressed.
- 3 Now move your machine to the ending point of your measurement and press **End**. The end button will turn green, and the displayed Measurement results will freeze on the screen.
- 4 The screen will display the horizontal, vertical, and diagonal distances between the two points you set.
- 5 Press **Clear** to start a new measurement. The start and end buttons will return to the normal color, and the measurement results will clear.
- 6 When finished, press **Back** or **Main Screen** to resume quilting.

## Making Calculations

Your machine can be used to make quick calculations.

Press the **calculator** icon at the bottom of any quilting screen to access the **Calculator** screen.

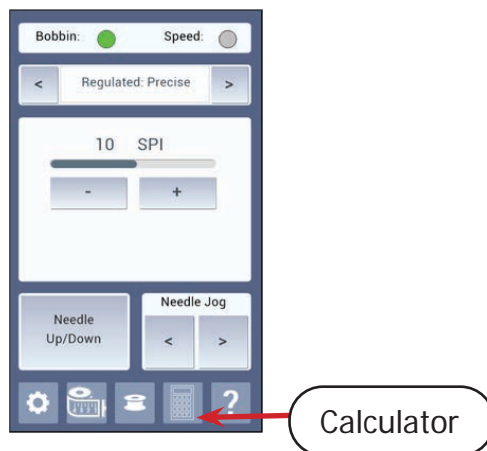

The Calculator will display.

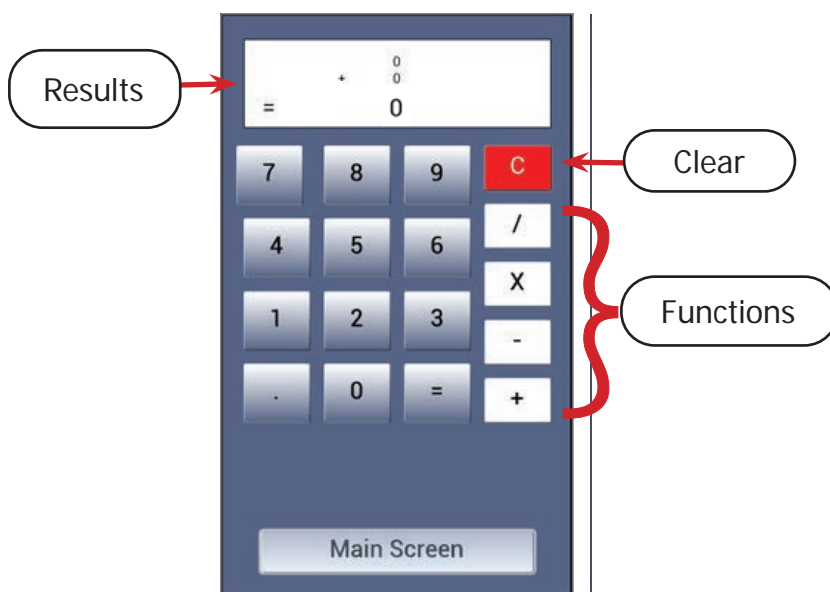

- 1 Use the calculator to add, subtract, multiply, and divide.
- 2 When finished, press **Main Screen** to resume quilting.

## Tracking Stitch Count & Run Time

To track the number of stitches your machine has sewn or hours it has run, press the “System Information” button from the Settings menu (see page 27).

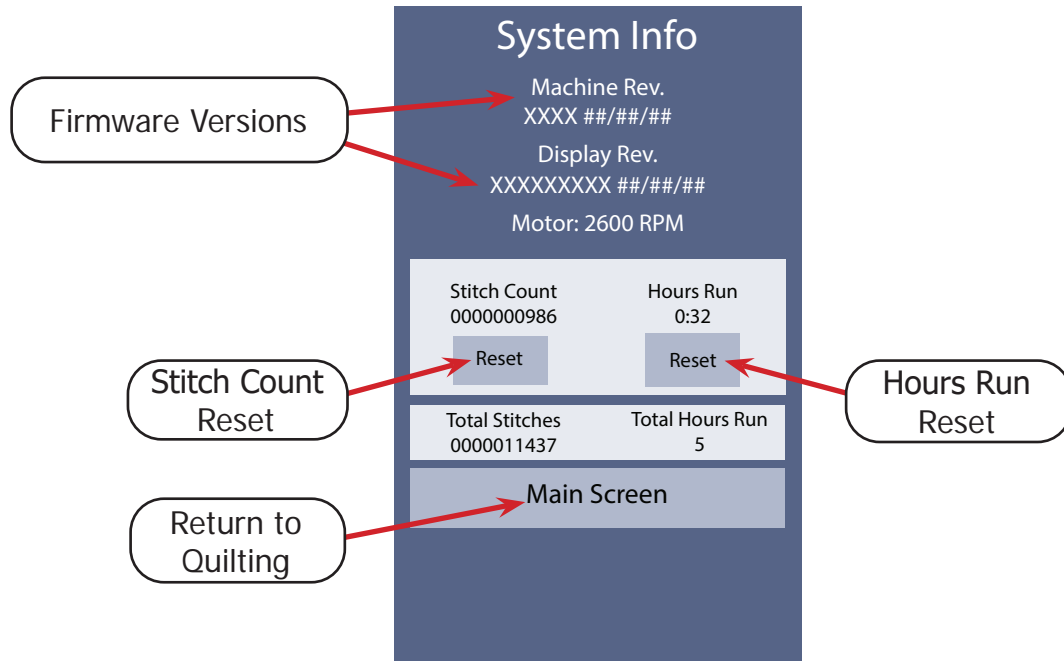

- **Stitch Count:** Displays the number of stitches since the last reset.

**Reset** Press to start the stitch count back at 0.

- **Hours Run:** Displays the number of hours and minutes run since the last reset.

**Reset** Press to start the hour count back at 0.

- **Total Stitches:** Shows the total number of stitches since the machine was purchased. This cannot be reset.
- **Total Hours:** Shows the total number of hours the machine has run. This cannot be reset.

**Tip:** It's recommended to oil your machine after 20 hours of use. The “Hours Run” counter can help keep track of when your machine is due to be oiled.

- 1 After cleaning and oiling your machine (see page 57), press **Reset** underneath **Hours Run**. This will set the hour count back to 0.
- 2 Check the **Hours Run** count regularly. When it reaches 20 hours, it's time to clean and oil the machine again. Repeat from step 1.

# Maintaining the Machine

Keep your machine performing at its peak by practicing good machine maintenance habits.

<b>Preparing the Oil Bottle.....</b>	<b>page 56</b>
<b>Oiling and Cleaning .....</b>	<b>page 57</b>
<b>Changing the Needle .....</b>	<b>page 60</b>
<b>Adjusting the Bobbin Cam.....</b>	<b>page 62</b>
<b>Adjusting the Hopping Foot.....</b>	<b>page 63</b>
<b>Reinstalling the Needle Plate .....</b>	<b>page 68</b>

This section of the manual covers oiling the machine, changing the needle, adjusting the bobbin cam and hopping foot, and reinstalling the needle plate.

## Preparing the Oil Bottle

### Parts & Tools Needed:

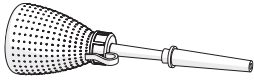

Oil Bottle

- Scissors (not included)

### Instructions

Take the following steps to prepare the oil bottle for use in oiling the machine.

- 1 Snip off about 1/4th of an inch from the tip of the plastic lid with a pair of scissors.

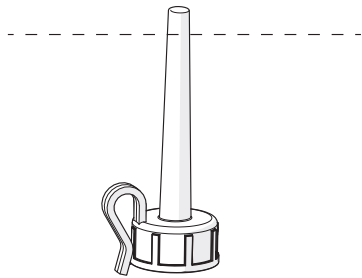

- 2 Place the applicator needle onto the top of the cap.

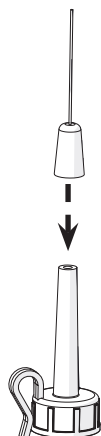

- 3 Peel the safety foil off the opening of the oil bottle.

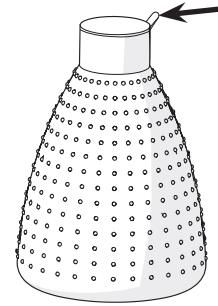

- 4 Carefully screw the lid onto the oil bottle.

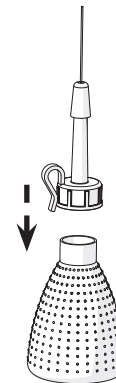

- 5 Hold bottle upside down and squeeze gently to apply oil. When not in use, cover the applicator needle with the safety cap.

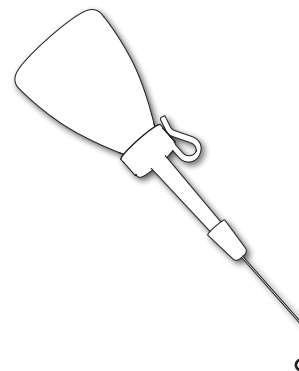



## Oiling and Cleaning

### Parts & Tools Needed:



Lint Brush

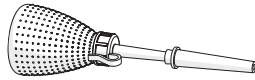

Oil Bottle

- Compressed Air Can (optional; not included)

### Instructions

#### Oil and Clean:

<b>Machine</b>	<ul style="list-style-type: none"> <li>• At the start of a new project</li> <li>• After 20 hours of use</li> <li>• After sitting without use for more than 30 days</li> </ul>
<b>Hook Assembly</b>	<ul style="list-style-type: none"> <li>• Every other bobbin change</li> </ul>

**Tip:** The Hours Run counter on the System Information page can be used to track hours of quilting time (see page 54).

Take the following steps to clean and oil the machine:

- 1 Power off the machine.
- 2 Set the **large thread tensioner** to "1" to expose the tensioner discs. Use the lint brush or a can of compressed air to clear away lint and thread remnants from between the discs.

**Note:** Lint build-up between the tensioner discs can prevent proper thread tensioning.

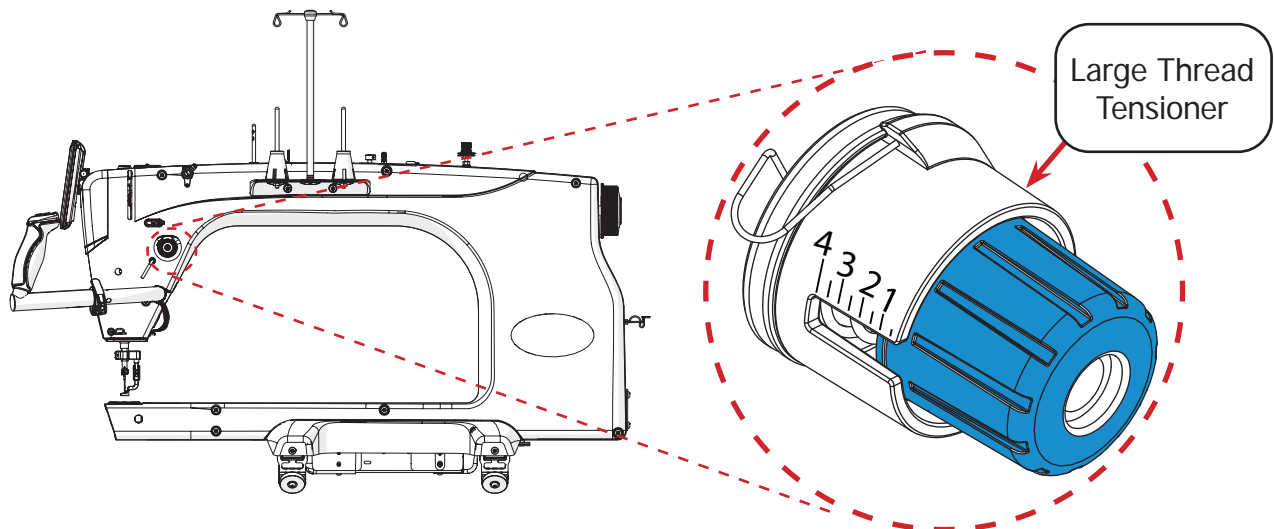

# Maintaining the Machine

## Oiling and Cleaning (Continued)

- 3 Clear debris from the spring and discs of the **small thread tensioner**.

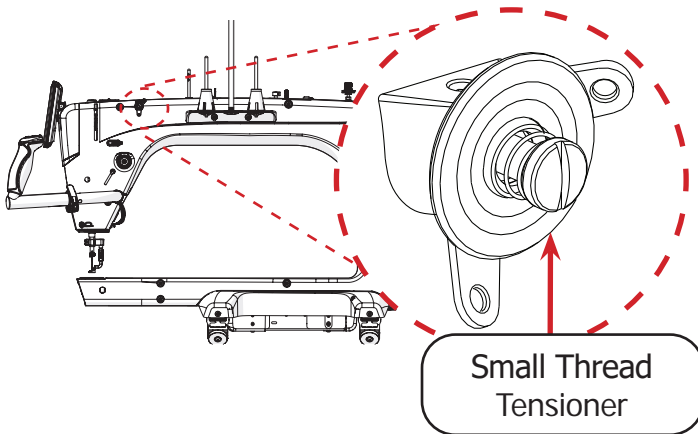

- 4 Pull the **lever** (shown in blue) on the bobbin case to remove it from the hook assembly.

**Note:** If the case won't release, try raising the needle.

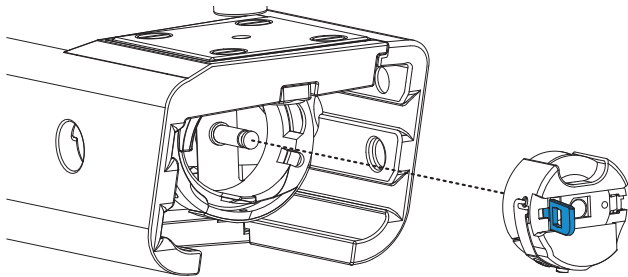

- 5 Take the bobbin from the case and set it aside. Clean the bobbin case with the lint brush or compressed air. Be sure to clean the area under the **bobbin tension thread arm**.

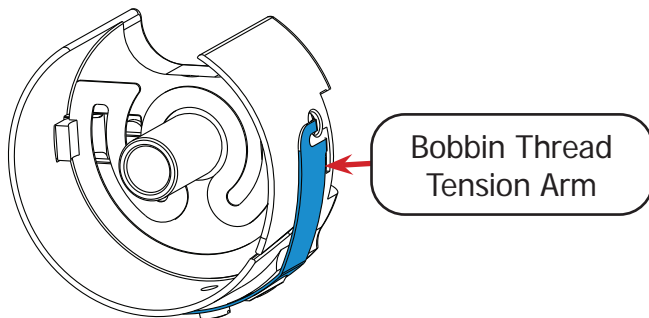

- 6 In and around the **hook assembly**, clear away any lint, cloth, and thread remnants using the lint brush or compressed air.

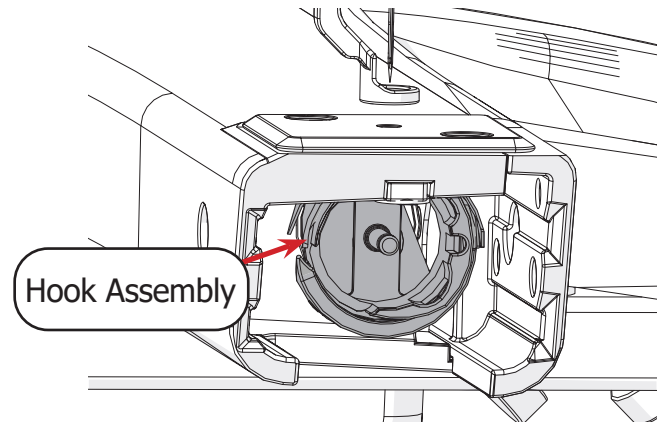

- 7 Rotate the **hand wheel** until the needle is halfway down. This will put the hook in the best position for oiling.

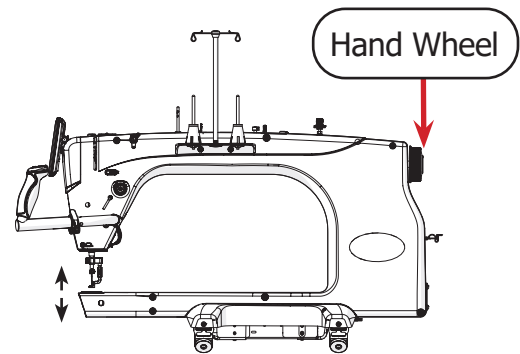

- 8 Place one to two drops of oil into the hook assembly between the **inner part** (shown in gray) and **outer part** (shown in blue).

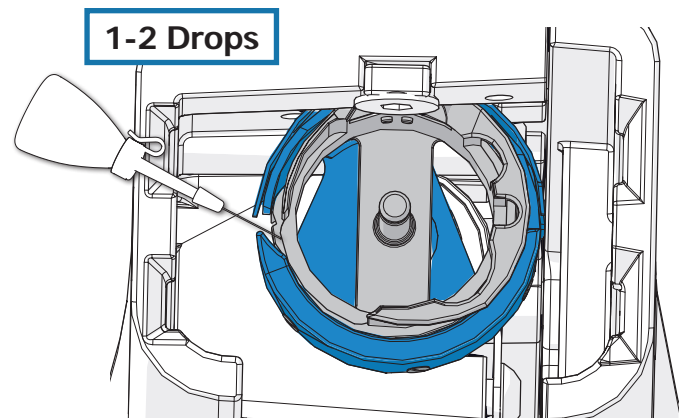

Oiling and Cleaning (Continued)

- 9 Reload the bobbin case and return it to the machine. For detailed instructions, see “Loading the Bobbin Case” on page 31.

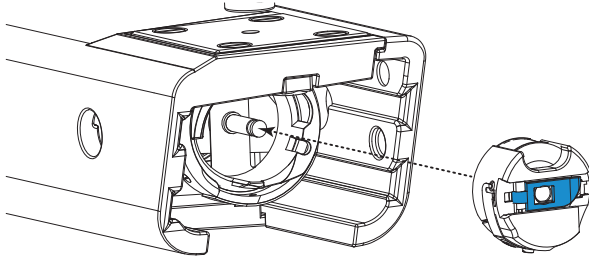

- 10 Place one to two drops of oil down the hole at the top of the machine, near the display.

**1-2 Drops**

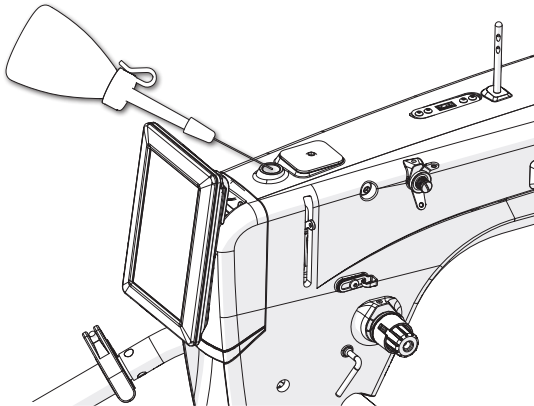

- 11 Power up the machine and test a few stitches to ensure the machine is running smoothly.

- 12 Regularly wipe down the **needle bar** to prevent the accumulation of oil that can stain your fabric.

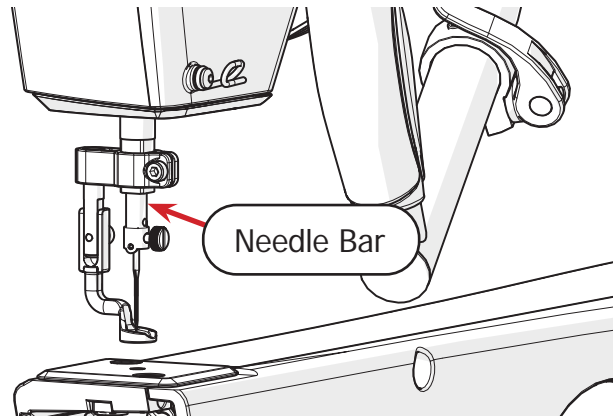

## Maintaining the Machine

### Changing the Needle

For information on selecting a needle, see "Choosing Your Needle" on page 83.

#### Parts & Tools Needed:



Needle

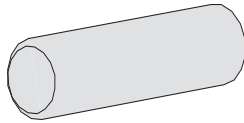

Needle Magnet

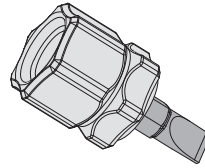

Flat-head Screwdriver

#### Instructions

A broken, bent, or burred needle may break thread, damage fabric, or even damage the machine. Always check that the needle is in good condition before starting a new project, and replace the needle after eight hours of use.

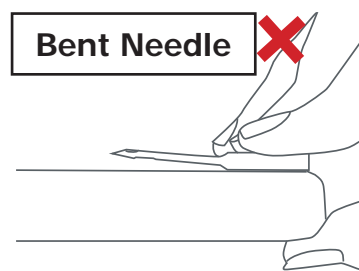
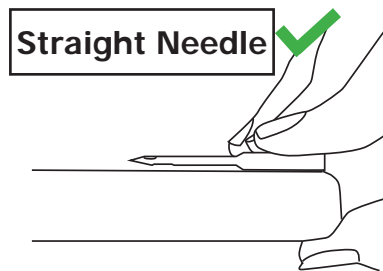

To avoid damage to the machine, please choose an approved needle style from the list below:

- DPX5 MR
- 134 MR
- 1955 MR

1 Power off the machine.

2 Raise the needle to the highest position with the **hand wheel**.

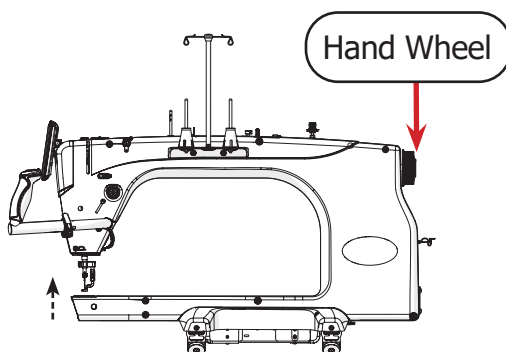

3 Loosen the **needle thumb screw** and pull out the needle. If needed, use a flat-head screwdriver to loosen the screw.

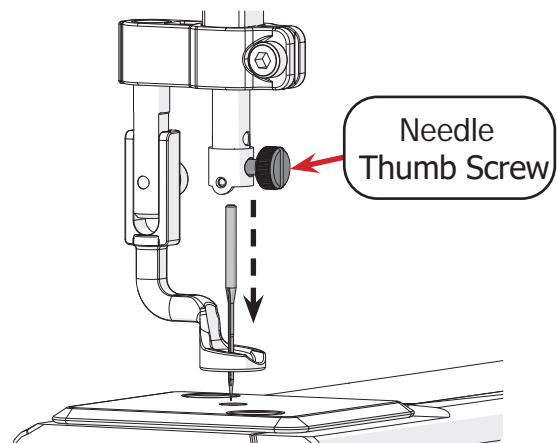

Changing the Needle (Continued)

- 4 Insert the new needle all the way into the needle bar. Check the **needle bar sight hole** above the thumb screw to make sure the **needle** is inserted all the way.

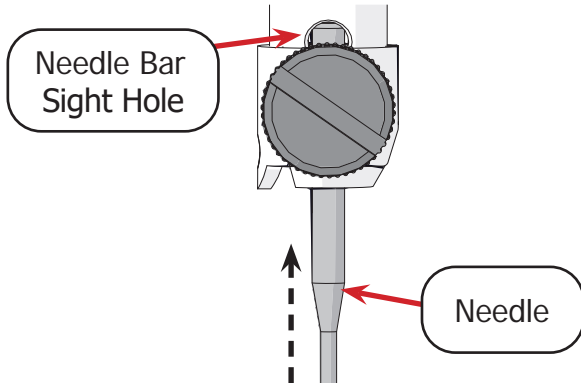

- 5 The **scarf**, a cut-out on the back of the needle, should face the throat of the machine. Place the **needle magnet** on the opposite side of the scarf.

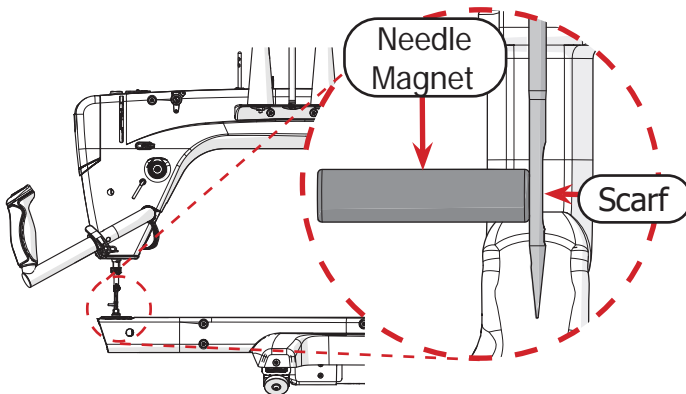

- 6 Use the needle magnet as a visual guide. Twist the needle until the **magnet** (shown in blue) points as straight out from the machine as possible. **Note:** Do not attempt to adjust the needle by moving the magnet directly.

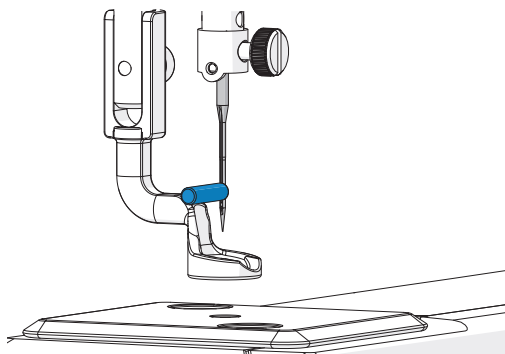

- 7 Hand-tighten the **needle thumb screw**. Do not over-tighten if using the flat-head screwdriver.

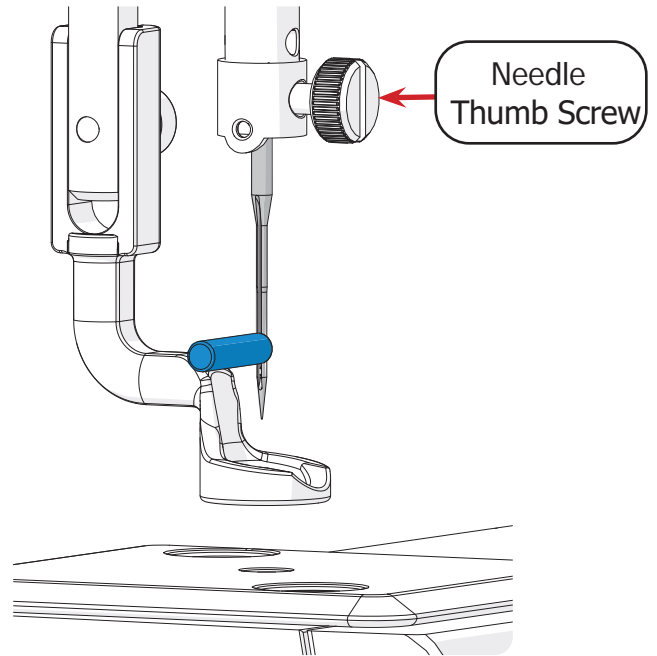

## Adjusting the Bobbin Cam

### Parts & Tools Needed:

- 1.5 mm Allen Wrench (not included)

### Instructions

The machine's bobbin cam is set so the bobbin will wind completely before the winder shuts off. To change how much the bobbin fills before the winding stops, take the following steps:

- 1 Power off the machine.
- 2 Place an empty bobbin onto the bobbin stand and flip the bobbin cam toward the bobbin. This will help estimate how far to adjust the bobbin cam.

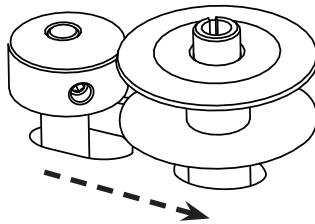

- 3 Loosen the **set screw** on the bobbin cam with a 1.5 mm Allen wrench until the top of the bobbin cam twists freely.

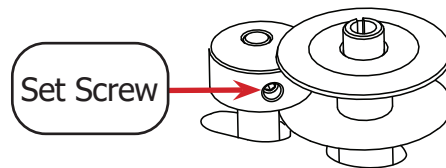

- 4 Point the set screw toward the bobbin to decrease the amount the bobbin will fill before the winder shuts off. Point the set screw away from the bobbin to increase the fill amount.

**Point away from bobbin to increase fill.**

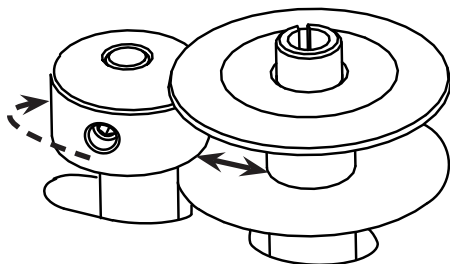

**Point toward bobbin to decrease fill.**

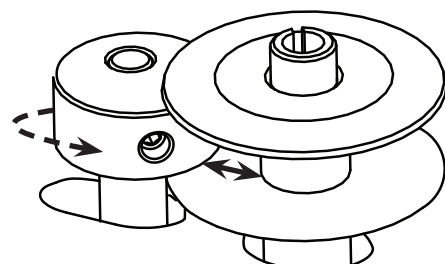

- 5 After choosing the desired distance, tighten the set screw with a 1.5 mm Allen wrench.

## Adjusting the Hopping Foot

### Parts & Tools Needed:

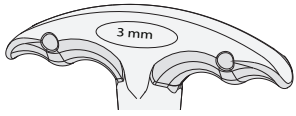

T-handle Allen  
Wrench 3 mm



Hopping Foot  
Height Tool

### Height Adjustment

When quilting with thick fabric or batting layers, the hopping foot may press down on the quilt too tightly and begin to drag. Alternatively, having the hopping foot too high can result in skipped stitches. The hopping foot can be raised or lowered to correct these problems. To adjust the hopping foot height, take the following steps:

- 1 Move the machine so it is not over fabric. Then use the **hand wheel** to drop the needle bar to the lowest position.

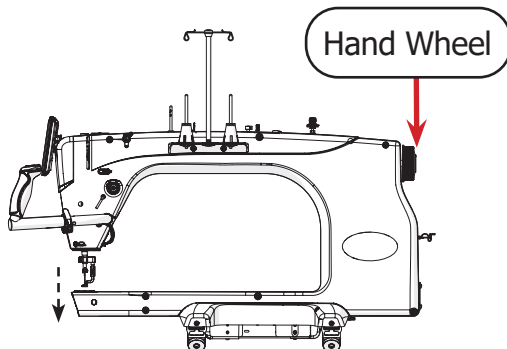

- 2 With the 3 mm Allen wrench, loosen the **hopping foot screw**.

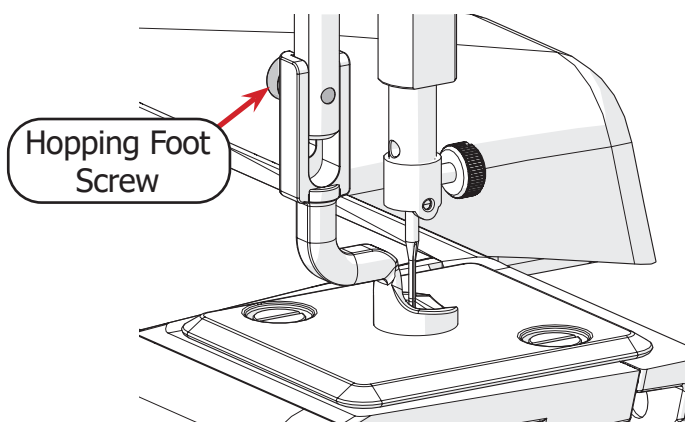

- 3 Slide the **hopping foot height tool** (shown in blue) underneath the **hopping foot**, around the needle.

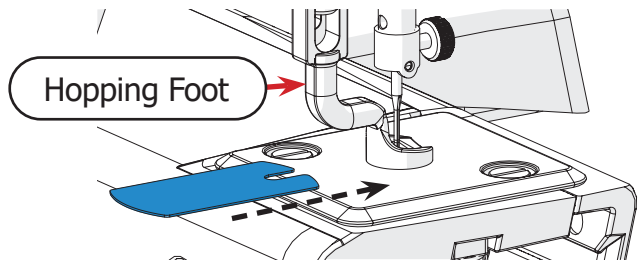

**Note:** The height tool prepares the machine for standard sized quilt batting and two layers of fabric. For thicker quilts, stack sheets of printing paper over the gauge to increase room underneath the hopping foot.

- 4 Lower the hopping foot until it rests on the height tool. Re-tighten the hopping foot screw.

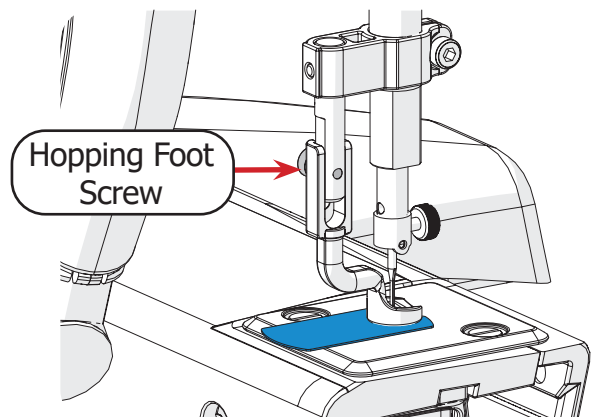

### Rotation Instructions

The hopping foot can be rotated to improve line of sight. To rotate the hopping foot, please take the following steps.

- 1 Power off the machine.
- 2 Rotate the **hand wheel** to lift the needle from the hopping foot.

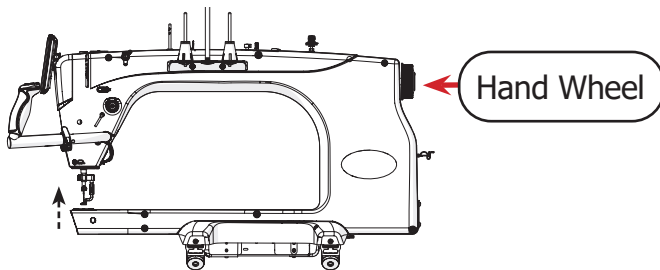

- 3 Use the 3 mm Allen wrench to remove the **screw** holding the hopping foot.

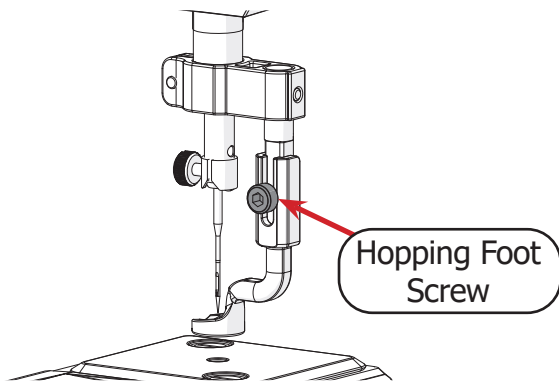

- 4 Slide the **hopping foot** from the press bar.

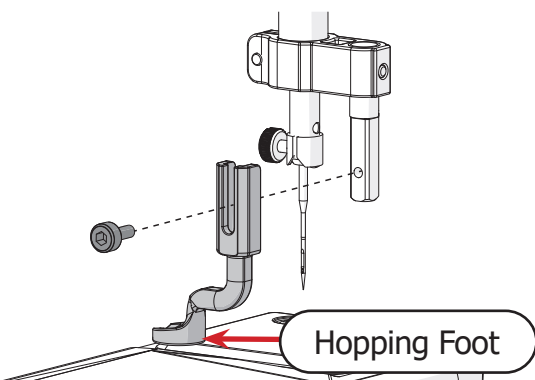

- 5 With the 3 mm Allen wrench, loosen the **collar screw** that holds the **hopping foot collar** to the press bar.

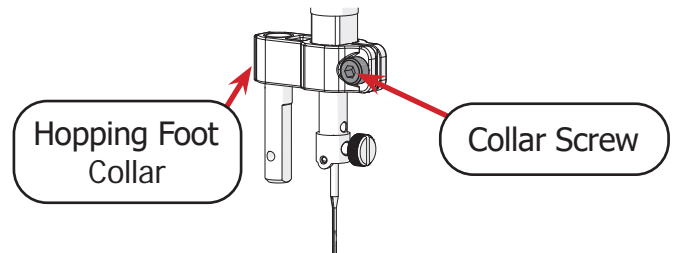

- 6 Drop the hopping foot collar below the **press bar** and turn it to the desired position.

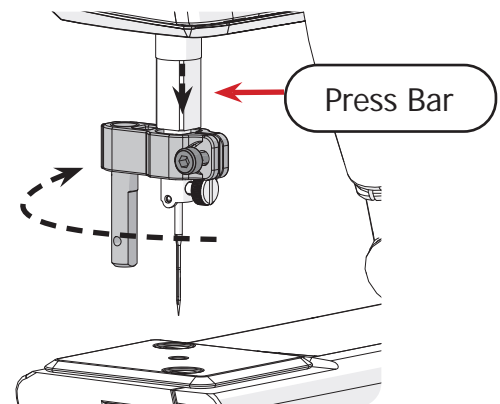

The hopping foot can be set to two positions:

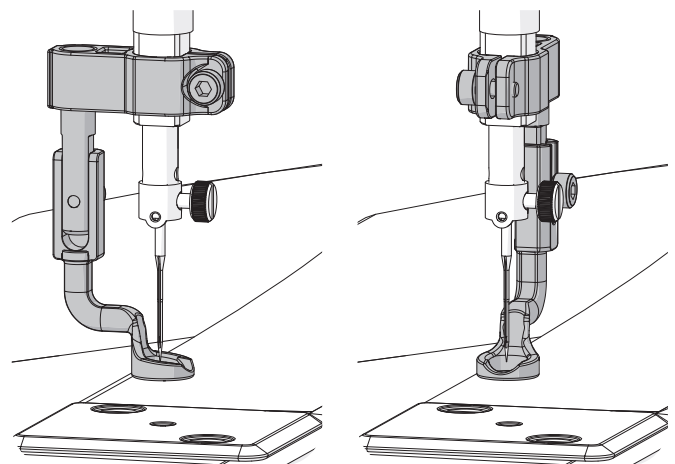



Adjusting the Hopping Foot (Continued)

- 7 Lift the hopping foot collar back up to the press bar so that the bottom of the collar is even with the bottom of the press bar, and re-tighten the **collar screw**.

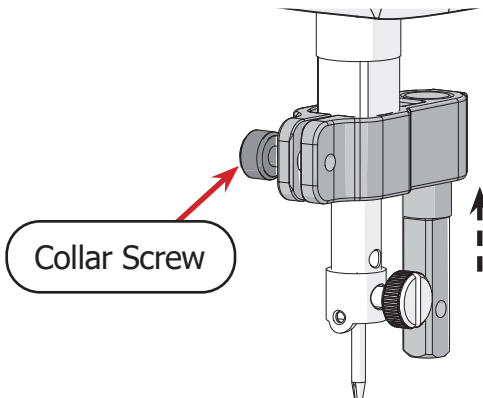

- 8 Slide the **hopping foot** into the collar and screw in place with the **hopping foot screw**.

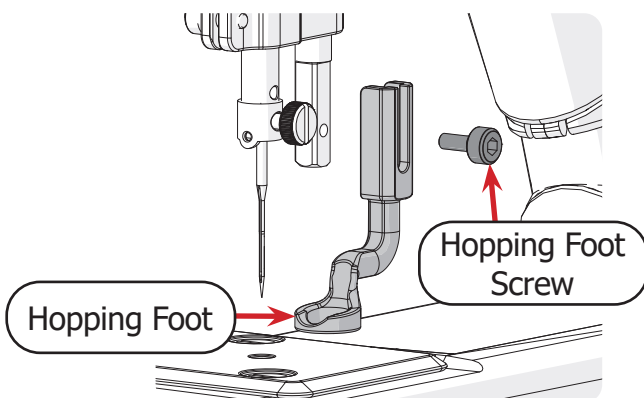

- 9 Double-check your hopping foot height (see page 63).

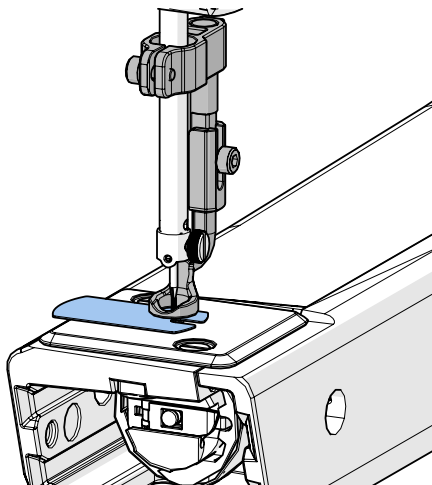

### Removal Instructions

To remove the hopping foot for maintenance or to adjust the hopping foot angle, take the following steps:

- 1 Power off the machine.
- 2 Rotate the **hand wheel** to lift the needle from the inside of the hopping foot.

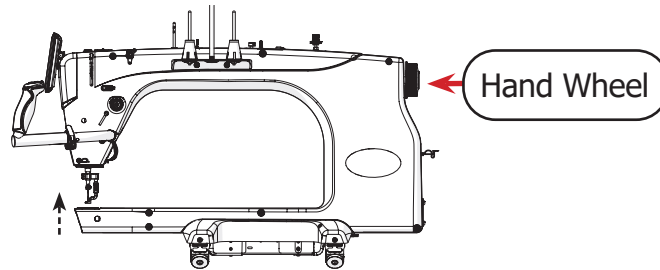

- 3 Use the 3 mm Allen wrench to remove the **screw** holding the hopping foot.

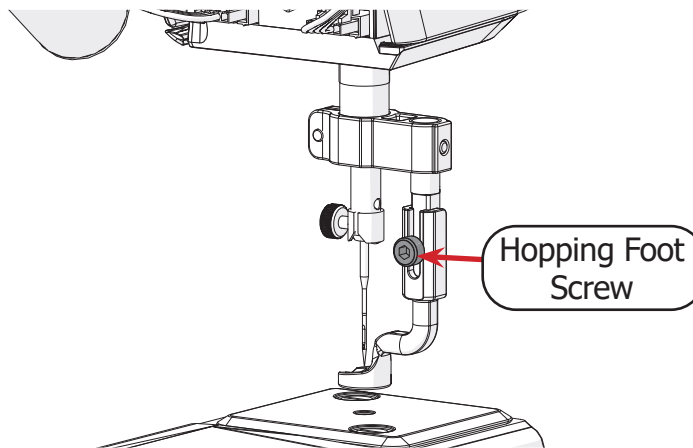

The **hopping foot** now slides free from the press bar.

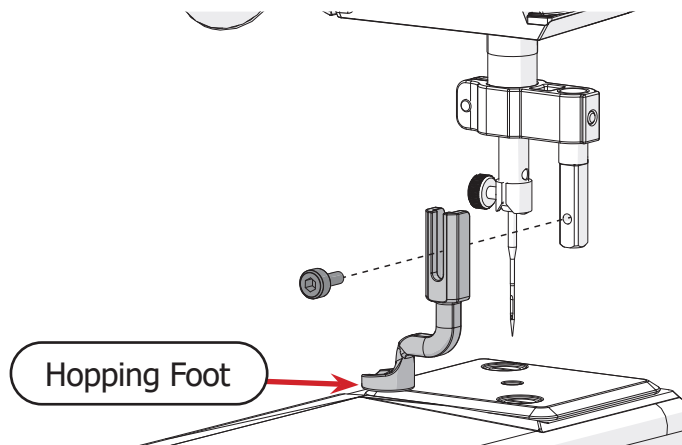

## Adjusting the Hopping Foot (Continued)

**Installation Instructions**

To install the hopping foot on your quilting machine, please take the following steps:

- 1 Power off the machine.
- 2 Slide the **hopping foot** to the slot in the hopping foot collar. Use the 3 mm Allen wrench and **hopping foot screw** to tighten in place.

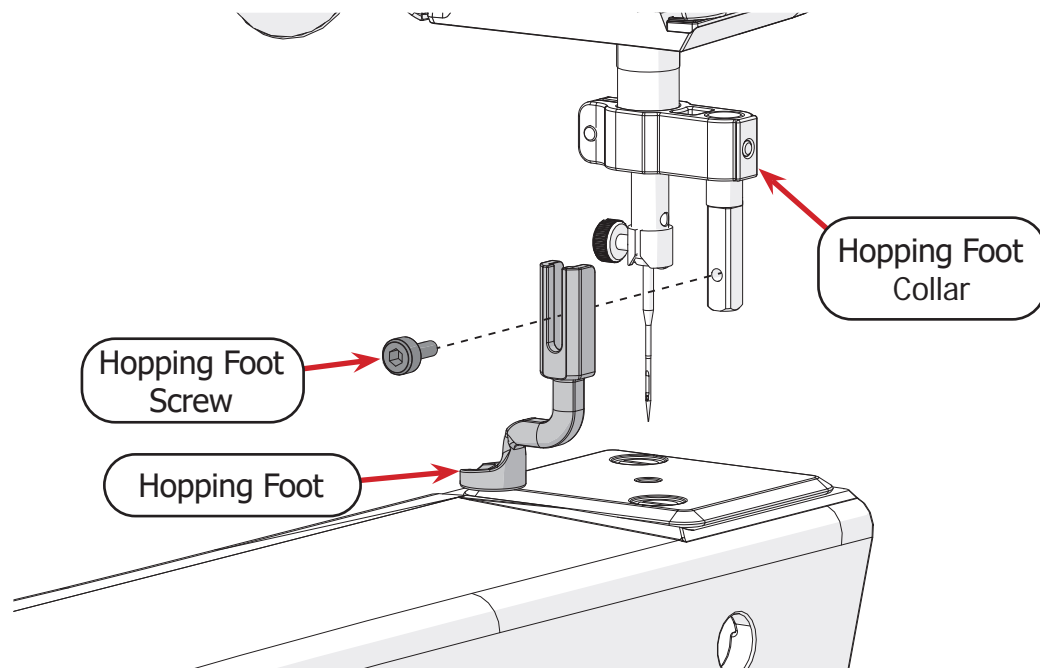

- 3 Adjust height as needed (see page 63).

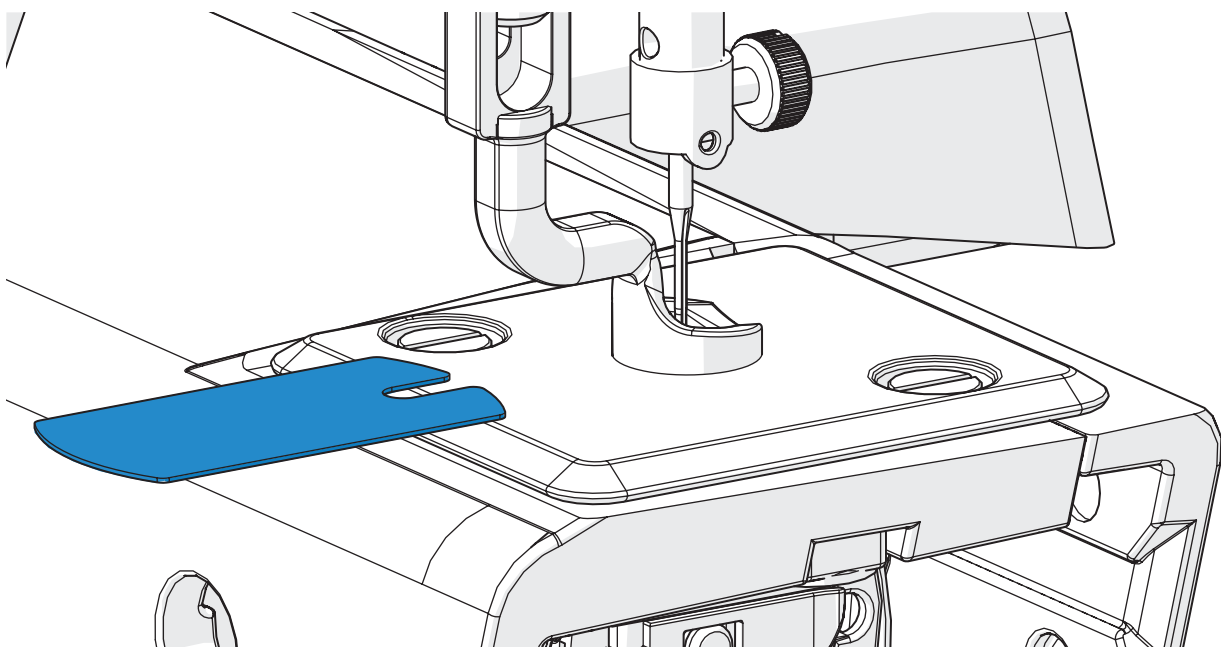

## Reinstalling the Needle Plate

### Parts & Tools Needed:

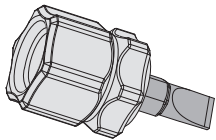

Flat-head Screwdriver

### Removal Instructions

To remove the needle plate from the quilting machine, take the following steps:

- 1 Power off the machine and raise the needle to the highest position using the **hand wheel**.

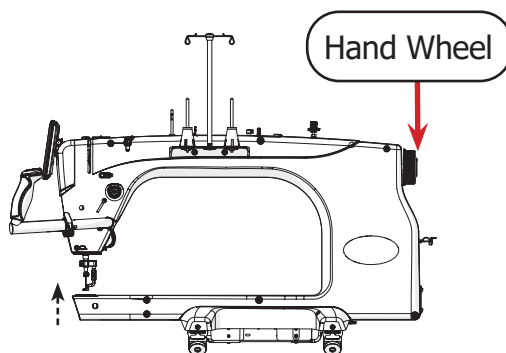

- 2 Use the flat-head screwdriver to remove the two **needle plate screws** (shown in gray).

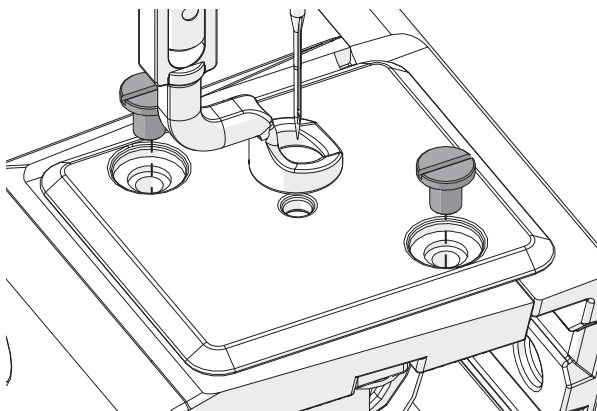

- 3 Slide the **needle plate** (shown in gray) from the machine.

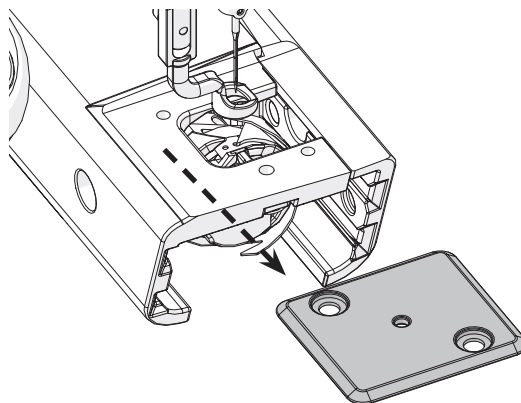

Reinstalling the Needle Plate (Continued)

Installation Instructions

To install the needle plate onto the quilting machine, take the following steps:

- 1 Power off the machine. Raise the needle to the highest position using the **hand wheel**.

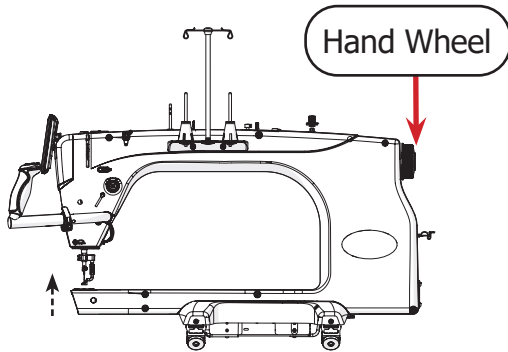

- 2 Slide the **needle plate** onto the machine.

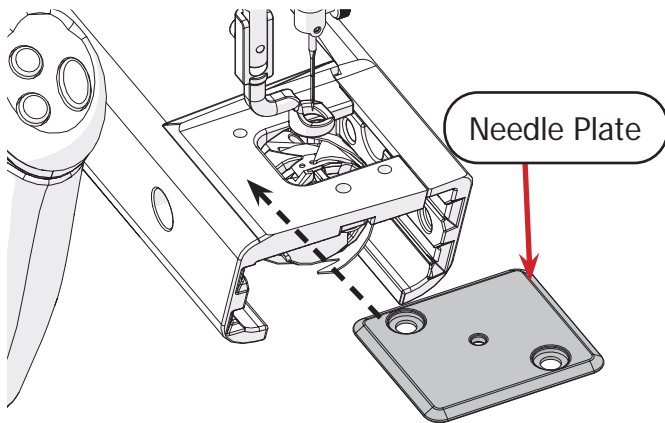

- 3 Align the screw holes on the needle plate with those on the machine.

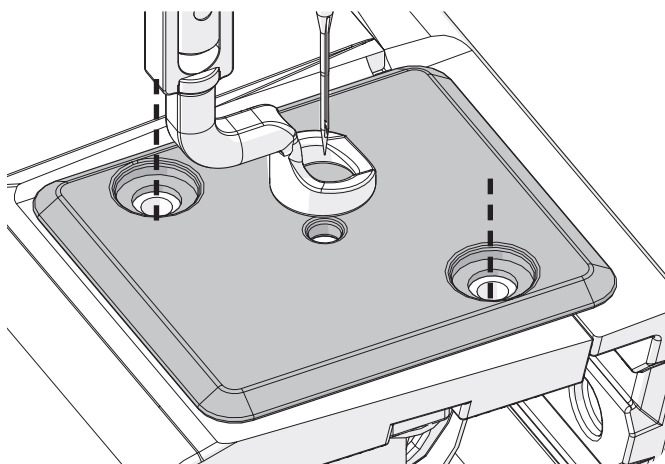

- 4 Slowly lower the needle with the hand wheel. The needle should slide into the center hole without contacting the needle plate.

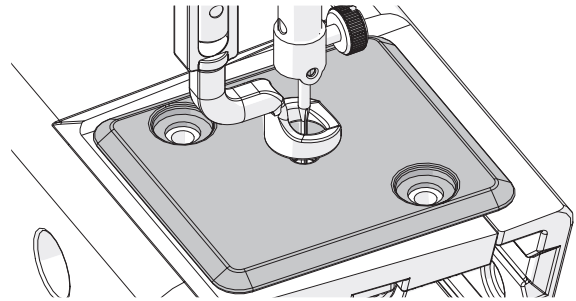

- 5 Place the two **needle plate screws** (shown in gray) into the plate. Make sure the needle plate is centered around the needle, and then tighten the screws with the flat-head screwdriver.

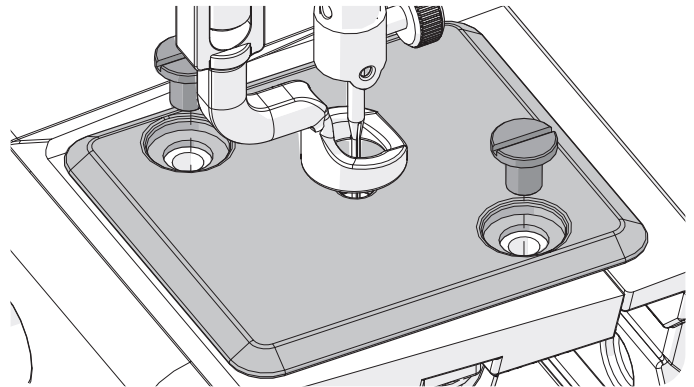

# Repairs and Diagnostics

The instructions in this section should only be taken at the direction of a Grace Company support technician. If you are experiencing problems with your machine, please contact our technical support team:

- **Phone:** (800) 264-0644
- **Email:** support@graceframe.com

<b>Checking the Firmware .....</b>	<b>page 71</b>
<b>Replacing the Encoder Spring .....</b>	<b>page 72</b>
<b>Reinstalling the Hook Holder .....</b>	<b>page 75</b>
<b>Timing the Machine .....</b>	<b>page 78</b>

This section of the manual covers replacing the encoder spring, installing the hook holder, timing the machine, and checking the machine and display firmware versions.

## Checking the Firmware

The control firmware versions for the machine motor and the touch display are found by pressing “System Information” from the Settings menu (see page 27).

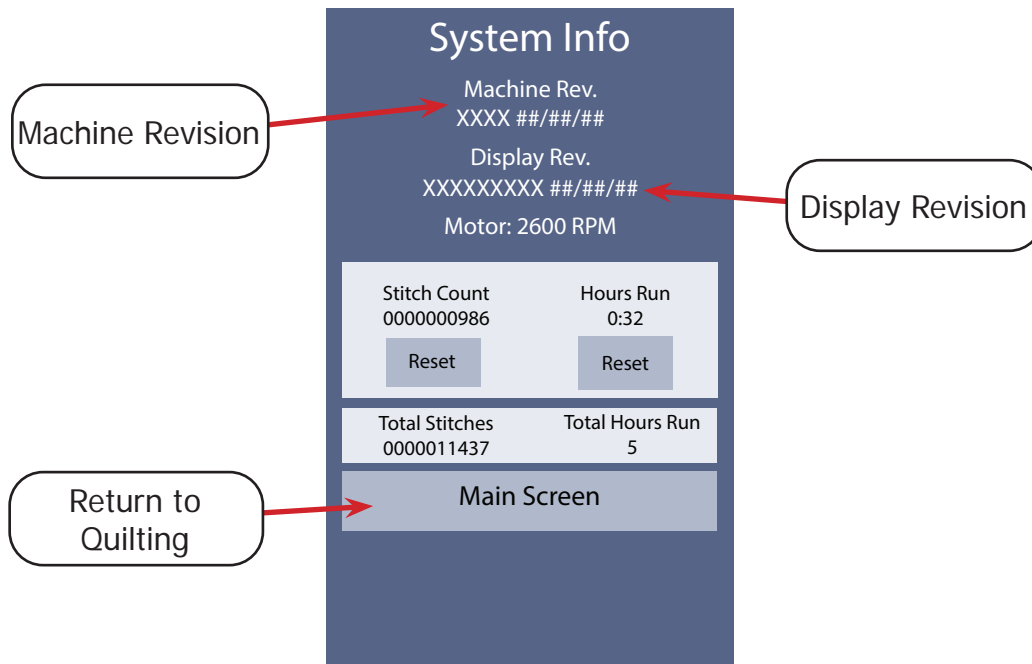

The following information and options display:

- **Main Screen:** Press to leave the System Information page and go back to quilting.
- **Machine Revision:** Shows the latest firmware version for the machine.
- **Display Revision:** Shows the latest firmware version for the touch display.

**Note:** For information on the stitch and hour count feature, see page 54.

# Replacing the Encoder Spring

Please speak to a Grace Company support technician before attempting these instructions.

## Parts & Tools Needed:

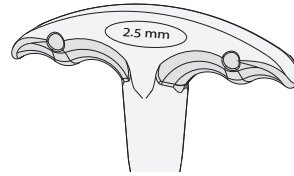
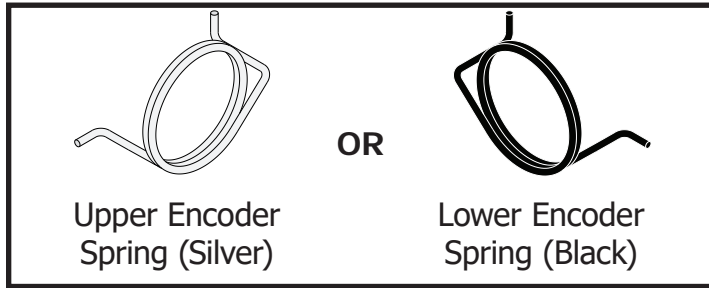

T-handle Allen Wrench 2.5 mm

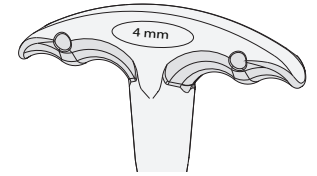

T-handle Allen Wrench 4 mm

## Instructions

If the encoder spring is over-tensioned, it may break and need to be replaced. To replace the encoder spring, take the following steps:

- 1 Determine the correct spring to use in the repair:



**Upper Encoder:** Attached to the wheel on the machine. Use the silver spring.



**Lower Encoder:** Attached to the wheel on the bottom carriage. Use the black spring.

- 2 Unplug the encoder cable from the machine.

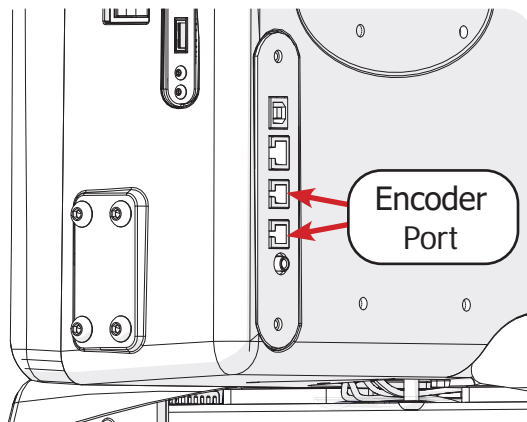

- 3 Loosen the **lock collar screw** with the 2.5 mm Allen Wrench until the **lock collar** (shown in blue) can twist freely.

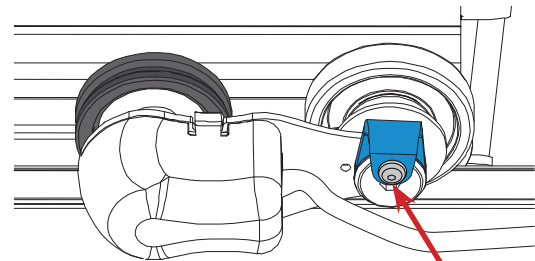

Lock Collar Screw

- 4 Use the 4mm Allen wrench to loosen the **encoder screw** and remove the encoder and wheel.

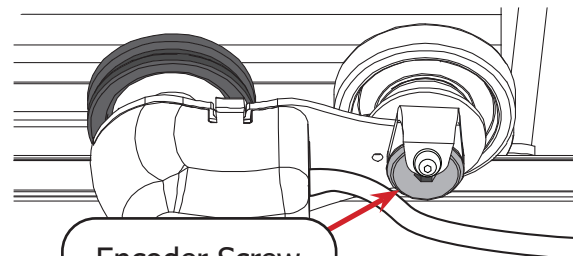

Encoder Screw



## Replacing the Encoder Spring (Continued)

- 5 Remove the **plastic stop**, **wheel spacer**, **washer**, broken **encoder spring**, and **shoulder spacer** from the encoder.

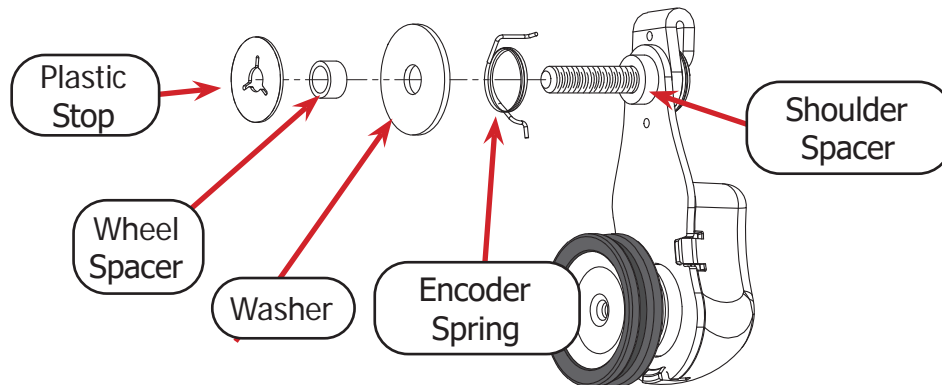

- 6 Pull on the **lock collar** to remove it from the encoder screw.

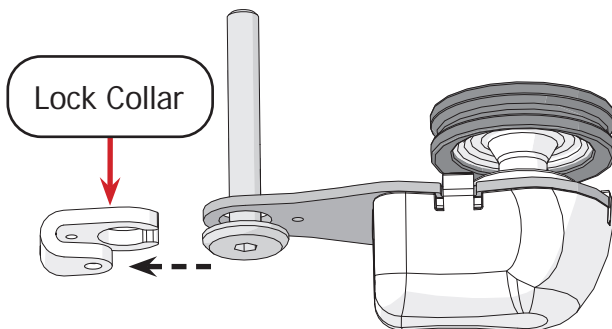

- 7 Place the replacement spring over the encoder screw, and insert the **short arm** of the spring all the way through the hole on the encoder base.

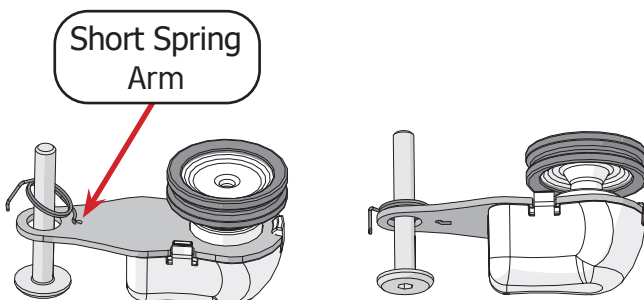

- 8 Place the **long arm** of the encoder spring arm into the hole on the encoder **lock collar**.

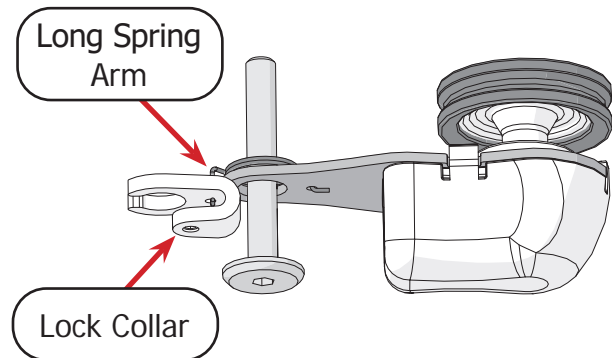

- 9 Without allowing the arm to slip out of the lock collar, rotate the collar until it wraps around the encoder bolt.

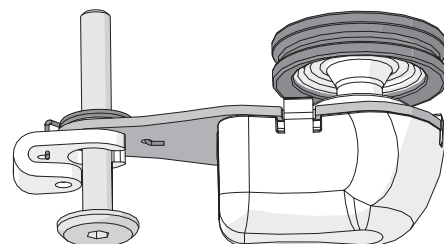

# Repairs and Diagnostics

## Replacing the Encoder Spring (Continued)

- 10 Adjust the screw and lock collar so the head of the screw slides in between the lock collar.

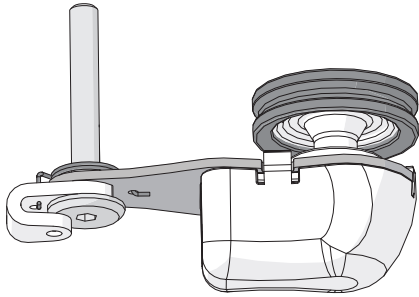

- 13 Complete the assembly instructions for the encoder you repaired.



For the upper encoder (silver spring) assembly instructions, see page 21.



For the lower encoder (black spring) assembly instructions, see page 23.

- 11 Slide the **shoulder spacer** onto the screw with the thinner side toward the head of the bolt.

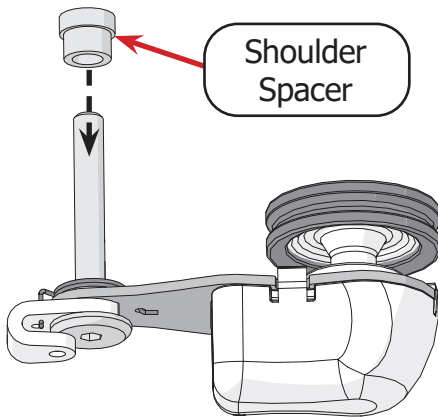

- 12 Next, place the **washer**, **wheel spacer**, and **plastic stop** onto the encoder screw.

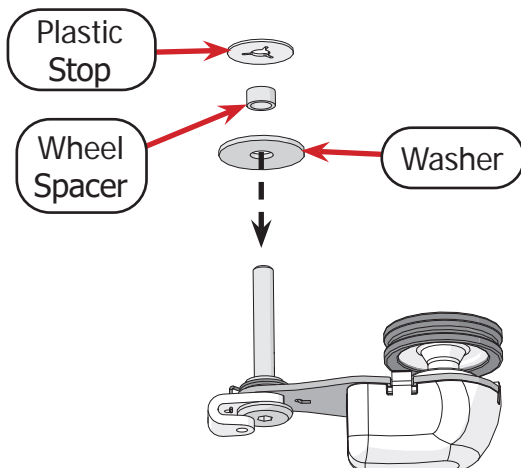

## Reinstalling the Hook Holder

Please speak to a Grace Company support technician before attempting these instructions.

### Parts & Tools Needed:

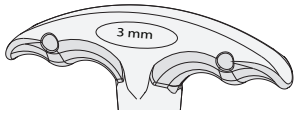

T-handle Allen  
Wrench 3 mm

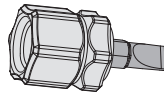

Flat-head Screwdriver

### Removal Instructions

The hook holder keeps the hook assembly in place. The following procedure should only be attempted if determined necessary by a Grace Company support technician. If done incorrectly, major machine problems can result.

- 1 Turn off the machine.
- 2 Rotate the **hand wheel** to raise the needle to the highest point.

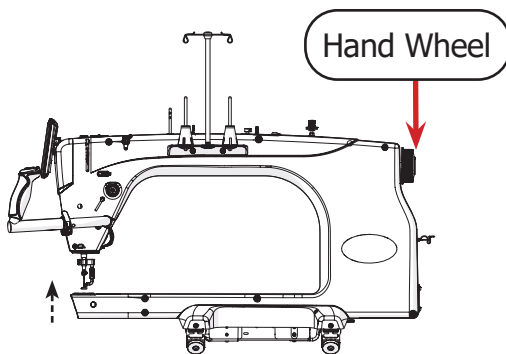

- 3 With the 3mm Allen wrench, remove the **hook holder screw** that attaches the hook holder to the machine.

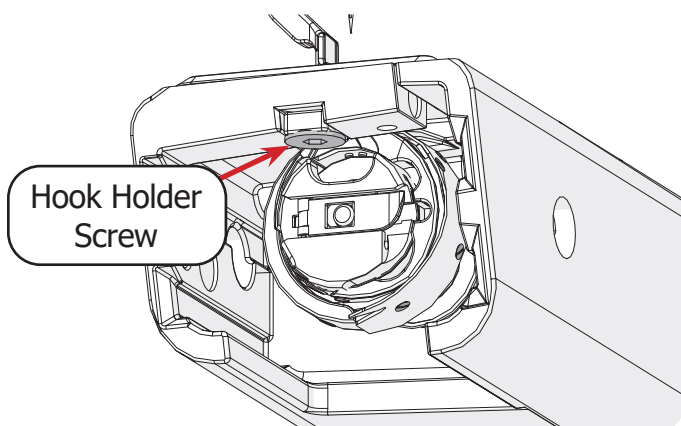

- 4 Slide the **hook holder** (shown in blue) from the hook assembly.

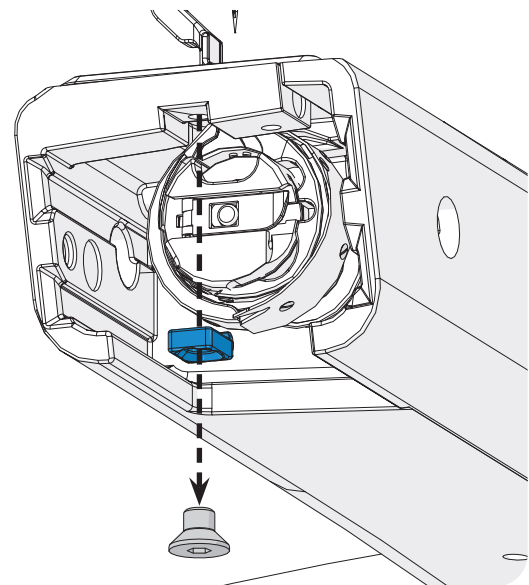

### Installation Instructions

- 1 Turn off the machine.
- 2 Rotate the **hand wheel** to raise the needle to the highest point.

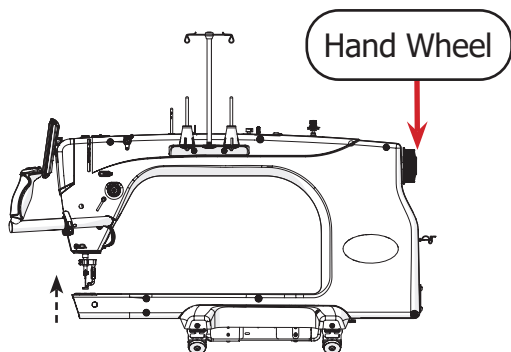

- 3 Remove the bobbin case (see "Loading the Bobbin Case" on page 31).

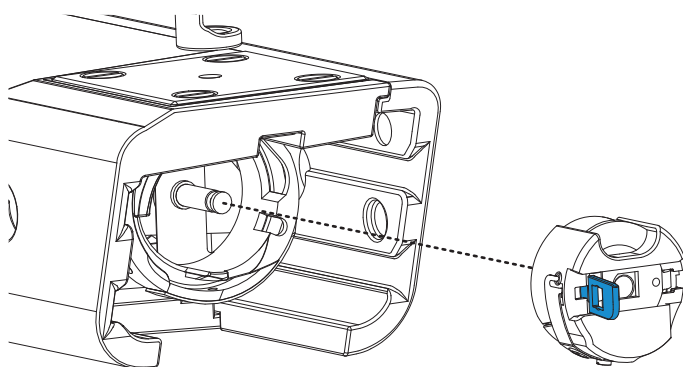

- 4 Remove the needle plate using the flat-head screwdriver (see "Reinstalling the Needle Plate" on page 68).

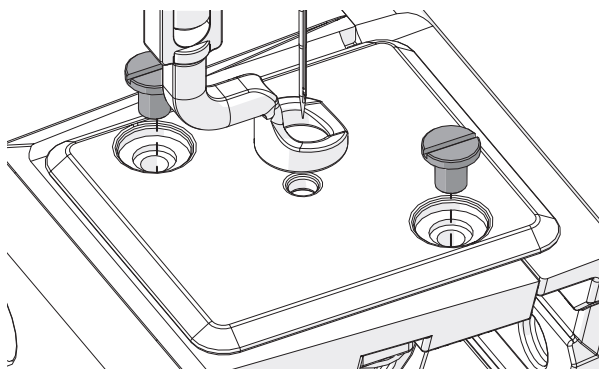

- 5 Turn the inside part of the **hook assembly** (shown in blue) so that the **positioning guide** is at the highest point.

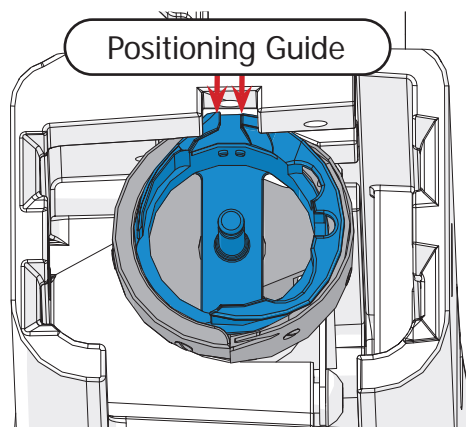

- 6 Slide the finger of the **hook holder** (shown in gray) into the middle of the hook assembly's positioning guide.

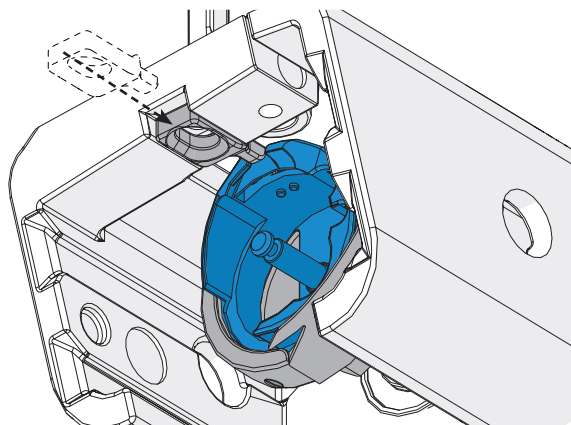

- 7 Attach loosely with the **hook holder screw**. Do not tighten.

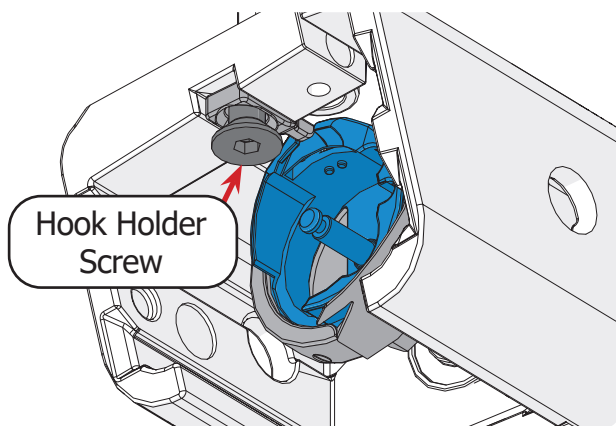

## Reinstalling the Hook Holder (Continued)

- 8 Align the **hook holder** with the inside edge of the **positioning guide**, as shown below.

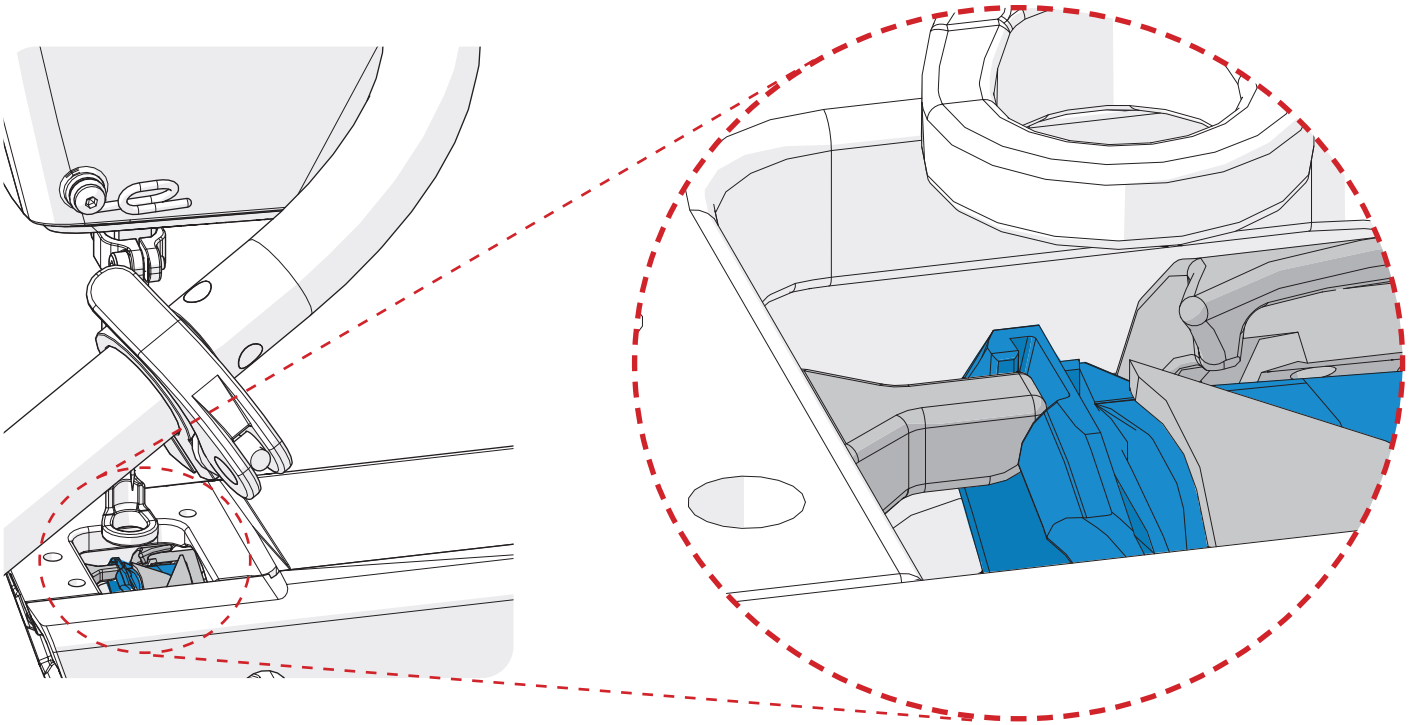

- 9 Tighten the hook holder screw to fasten the hook holder in place. The inside part of the hook assembly should no longer rotate freely by hand.

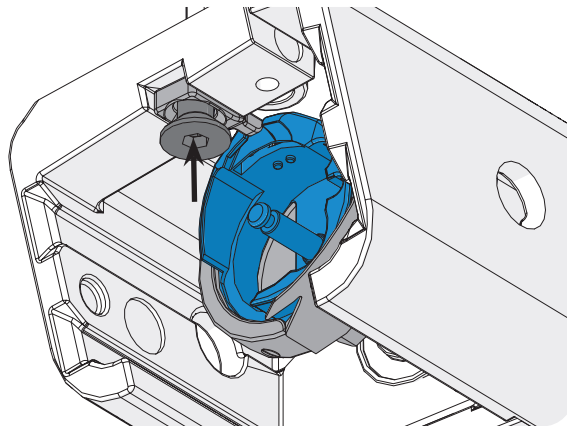

# Timing the Machine

Please speak to a Grace Company support technician before attempting these instructions.

## Parts & Tools Needed:

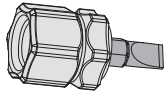

Flat-head Screwdriver

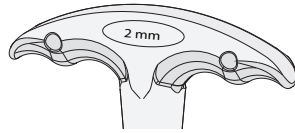

T-handle Allen Wrench 2 mm

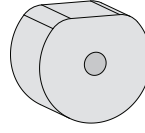

Timing Spacer Tool

## Instructions

Timing your machine aligns the needle and hook assembly so that they are in the correct places during the creation of a stitch. Improper timing can result in damage to the machine and needle, or make sewing impossible. Please consult with a Grace Company support technician before attempting to adjust the timing on your machine.

- 1 Turn off the machine.
- 2 Remove the hopping foot for better visibility (see page 64).

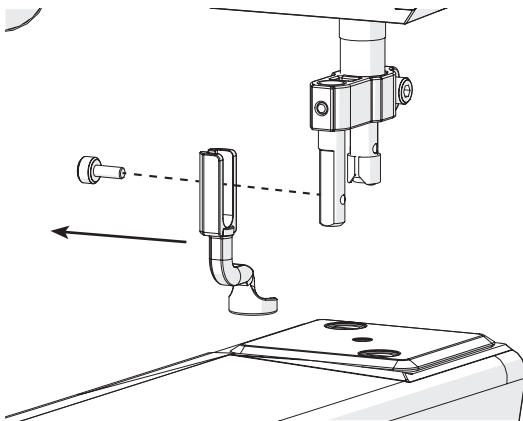

- 3 Remove the needle and replace if bent or damaged (see page 60).
- 4 Remove the bobbin case from the hook assembly (see page 31).

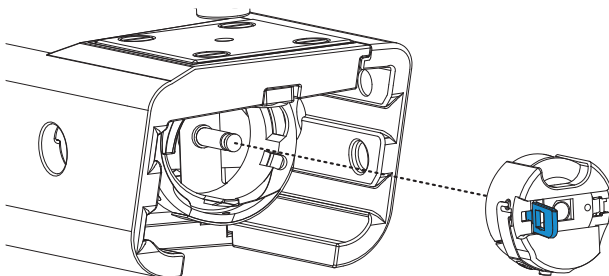

- 5 Remove the needle plate (see page 68).

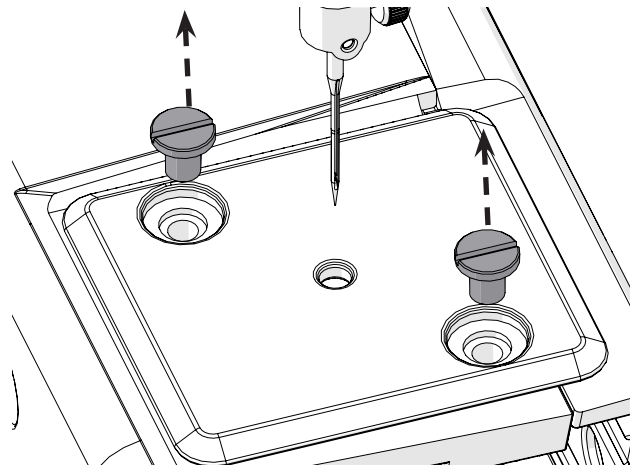

- 6 Look into the machine's **timing cut-out** and turn the hand wheel. The **hook assembly** will rotate.

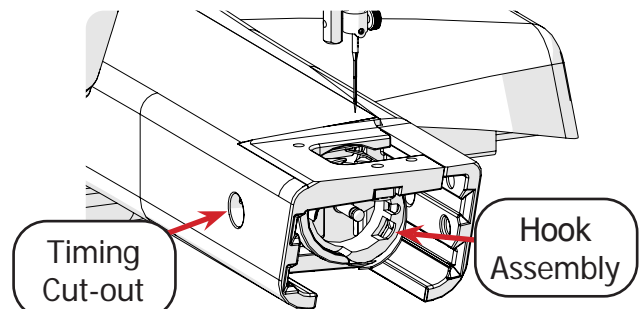

## Timing the Machine (Continued)

- 7 As each of the **3 set screws** aligns with the timing cut-out, loosen them with the 2 mm Allen wrench.

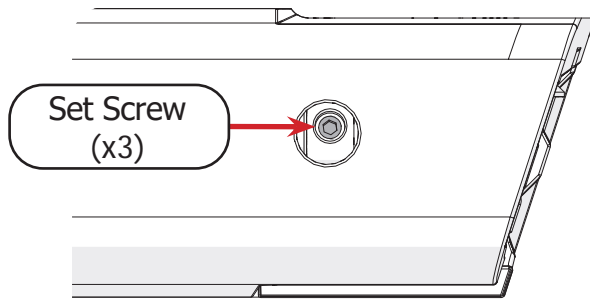

- 8 The **outside** part of the hook assembly (shown in blue) now rotates by hand. Turn the outside part of the hook assembly so that the **hook** is at the top.

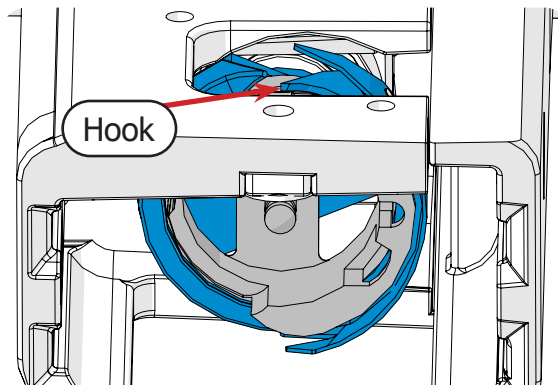

- 9 Hold the Hook Assembly and carefully rotate the hand wheel counter-clockwise to drop the **needle** (shown in gray) to its lowest point. Continue rotating the hand wheel the same direction. The needle should begin to raise up.

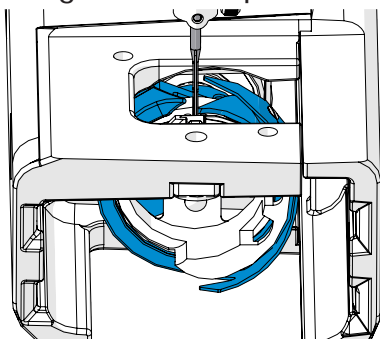

- 10 Stop raising the needle once the eye is about level with the **hook** (shown in blue). Do not continue to raise the needle. If the needle goes too high, start over at step 8.

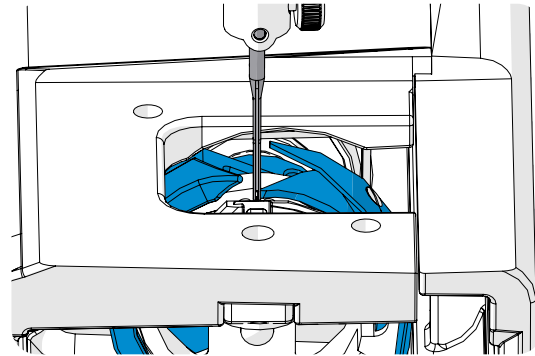

- 11 Slip the **timing spacer tool** (shown in blue) into the hook assembly with the flat side facing up. Then turn the timing tool until the flat side faces down.

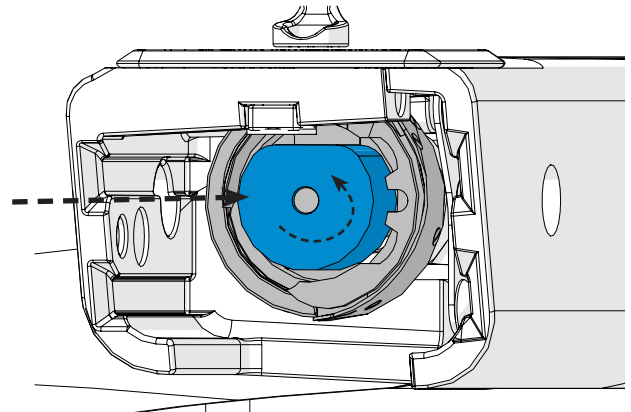

- 12 Turn the hand wheel clockwise to bring the **needle** back down until it rests on top of the timing spacer. Do not let the needle rise to the top before bringing it back down or you will need to repeat steps 8-11.

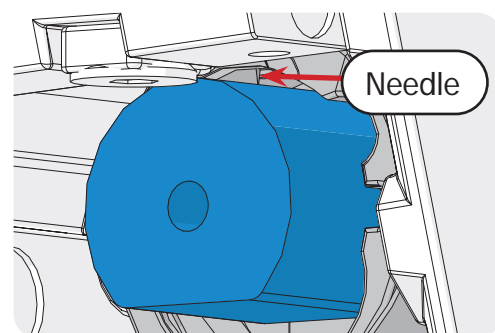

## Repairs and Diagnostics

### Timing the Machine (Continued)

- 13 Position the tip of the **hook** (shown in blue) with the center of the **Needle Scarf** (shown in gray). This is easier to see from the back of the machine.

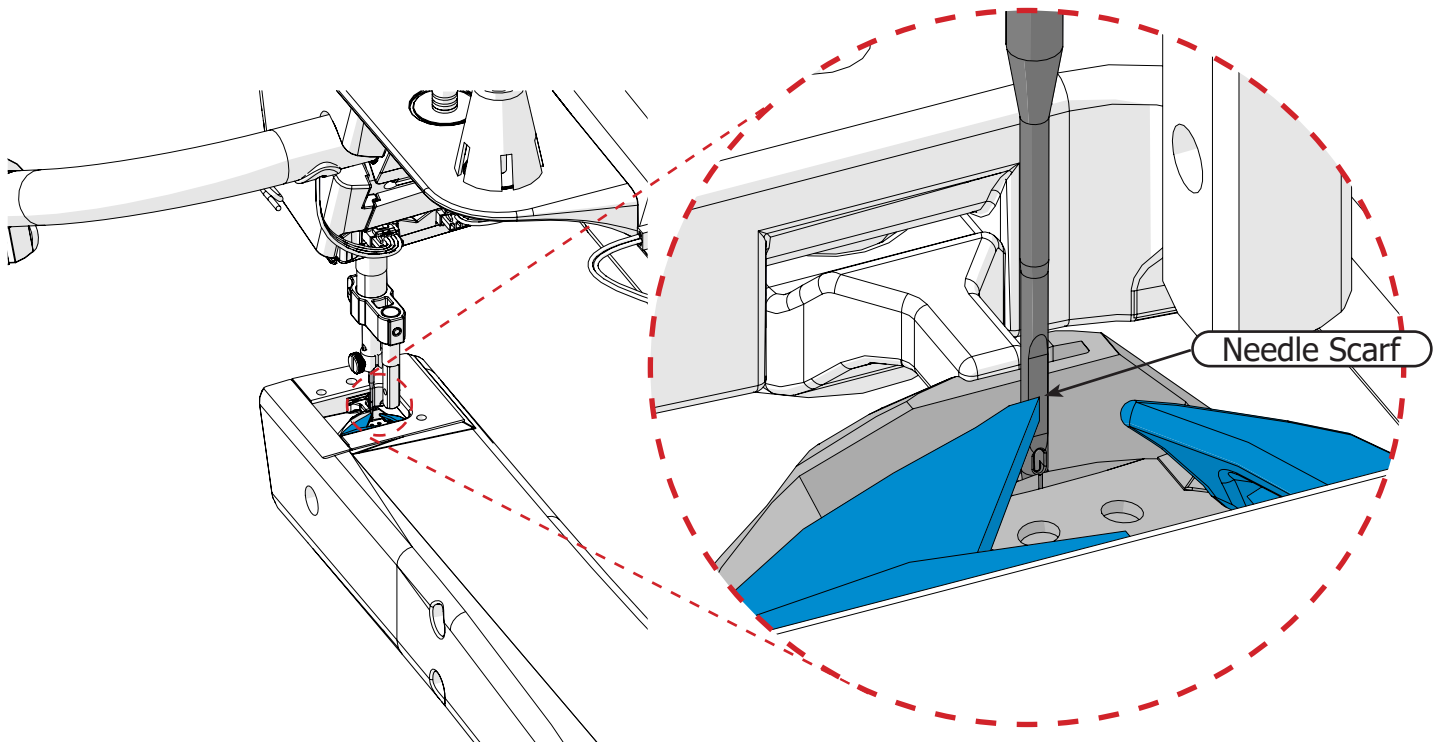

- 14 Pull the hook assembly toward the front of the machine until the hook is as close to the needle as possible without touching

- 15 Use the 2 mm Allen wrench to tighten one of the three **set screws** through the timing cut-out window on the left.

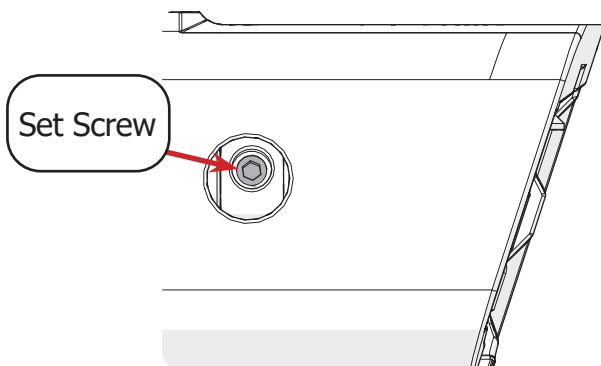



## Timing the Machine (Continued)

- 16 Turn the timing spacer tool until the flat side is facing up and then remove it from the machine.

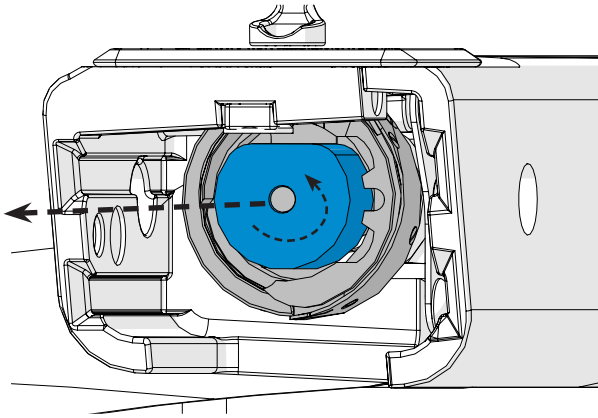

- 17 Turn the hand wheel a full rotation to listen for clicking noises and to ensure the needle does not bend or hit the hook.
- 18 Tighten the two remaining **set screws** through the timing cut-out.

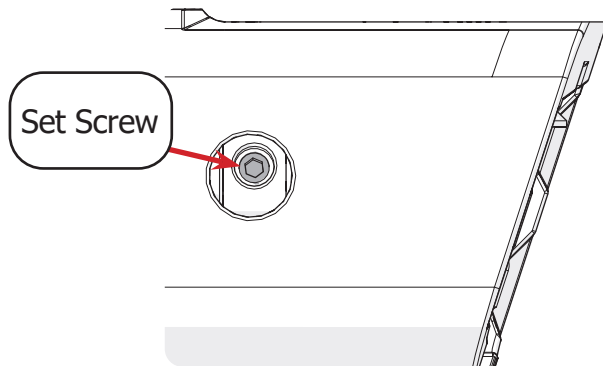

- 19 Replace and align the needle plate (see page 69). Make sure the needle is in the center of the needle plate.
- 20 Replace the bobbin case (see page 31).
- 21 Replace the hopping foot and adjust hopping foot height (see page 67).
- 22 Test the machine and listen for any unusual noises. If there are any skipped stitches, the hook is too far away from the needle. If the thread breaks, the hook is too close to the needle.

# Appendix

This section of this manual covers additional information on quilting with your machine.

- Choosing Your Needle .....page 83**
- Choosing Your Thread .....page 85**
- Choosing Your Fabric and Batting .....page 88**
- Troubleshooting Guide .....page 89**
- Index .....page 91**

## Choosing Your Needle

Using the wrong type of needle, or using a needle that is bent, broken, or blunt, can damage the fabric, the machine, and needle. For best results:

- Use the recommended needle style for your machine (see below).
- Use the needle size appropriate for the weight and type of thread you're using (see below).
- Never use a needle that is dull, bent, burred, or damaged.
- Use multi-directional needles.
- Change your needle after 8 hours of use and at the beginning of each project.

### Needle Style

The following are the recommended needle styles for your machine:

- DPX5 MR
- 134 MR
- 1955 MR

### Needle Sizes

Choose the size of your needle based upon the thread you're using. Thicker thread requires a thicker needle. Remember, the thicker the thread, the lower the thread weight (wt.) number.

Needle Size	Thread Size and Type
14 / 90	<ul style="list-style-type: none"> <li>• mono-filament</li> <li>• 100 wt. silk</li> <li>• 60 wt. polyester</li> </ul>
16 / 100	<ul style="list-style-type: none"> <li>• mono-filament</li> <li>• 60 wt. polyester or cotton</li> <li>• 50 wt. cotton</li> </ul>
18 / 110	<ul style="list-style-type: none"> <li>• 50 wt. polyester</li> <li>• 40 wt. cottons and polyester</li> <li>• 30 wt. cotton and polyester</li> </ul>
20 / 125	<ul style="list-style-type: none"> <li>• 30 wt. or heavier of any thread</li> </ul>

## Needle Diagram

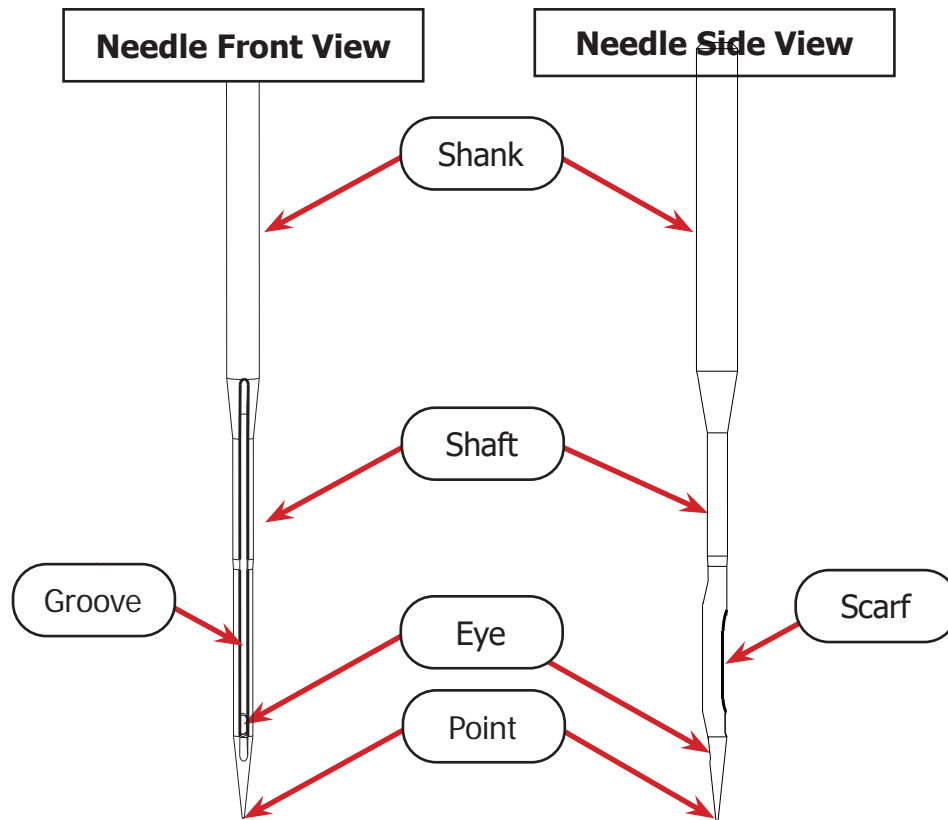

- **Shank:** Where the needle bar grasps the needle.
- **Shaft:** The long, narrow part of the needle. Needle size is based upon the diameter of the needle shaft.
- **Groove:** Reaching from the top to the bottom of the needle shaft, the groove allows thread to pass through the fabric more easily and without getting damaged.
- **Eye:** Hole near needle point where the needle is threaded.
- **Scarf:** A cut-away on the back of the needle that allows the needle to fit smoothly within the hook assembly when quilting.
- **Point:** The sharp end of the needle. Choose the type of needle point to fit your project, and always replace your needle once the point is dull.

## Choosing Your Thread

Choosing the best thread for your project is just as important as choosing the correct needle. Good thread is strong and can pass the “Yank Test” (see “Threading the Machine” on page 33). It holds its color well over time (colorfastness), and uses long fibers (extra-long staple) that resist pilling or creating lint.

Thread type and size determines not only which needle size to choose and what the thread tension must be set to on your machine, but also how visible the thread is on the project.

### For best results:

- Use a cone-style thread unless you have the thread spool accessory for your machine.
- Test the strength of thread before use with the “yank test” (see “Threading the Machine” on page 33).
- Practice using new thread on spare quilting materials to find the ideal thread tension. Write this information down and store it with your thread for later reference.
- Keep thread out of sunlight to prevent fading, and do not store near extreme temperatures.
- Select thread that is ideal for the fabric you’re using (see the chart below).
- Avoid using different thread type for the top thread than you’re using for the bottom thread.

### Thread Type Guide

Threads can be multiple strands, called plies, spun together, or it can be a single ply. The fibers that make up the ply can come from many sources, but the most common threads used in quilting are made from cotton, polyester, and silk. The unique properties of each material make some threads better suited for use on some fabrics than others.

Thread Type	Ideal Fabric
Cotton	<ul style="list-style-type: none"> <li>• Cotton</li> <li>• Linen</li> <li>• Rayon</li> </ul>
Polyester	<ul style="list-style-type: none"> <li>• Knit or Stretch</li> <li>• Woven synthetic</li> </ul>
Silk	<ul style="list-style-type: none"> <li>• Silk</li> <li>• Wool</li> <li>• Basting thread for all fabrics</li> </ul>

## Thread Size

The thickness of the thread is called the weight (wt.). This number is usually stamped on the edge of the top or bottom of the thread cone. Notice that as the thread becomes heavier and thicker, the weight decreases:

- 60 weight: Very thin, fine thread that will blend in to the fabric.
- 40 weight: Thicker thread that will show up on the fabric.

**Note:** choose matching weight and thread type when picking top and bottom (bobbin) threads.

**Tip:** Not all manufacturers will have the same sizing method for their thread. Threads can be measured by weight, tex, denier, or scaling that is unique to its brand. Take the time to understand how the sizing works for a brand you're considering, and keep a few common sewing rules in mind:

- The thicker the thread, the larger the needle required. A needle that is too thin can shred thread.
- The thinner the thread, the smaller the needle should be. A needle that is too large will cause uneven stitching and can leave holes in the fabric.

## Thread Processing

Sometimes thread is processed to change its properties. The chart below lists the processes common to cotton and polyester. No extra processing or treatments are typical for silk.

Thread Type	Processing
<b>Cotton</b>	<ul style="list-style-type: none"> <li>• <b>Mercerized:</b> Treated to improve strength and colorfastness.</li> <li>• <b>Glazed:</b> Waxed or coated to give a polished appearance. The coating may rub off and build up in machine.</li> <li>• <b>Gassed:</b> Exposed briefly to a gas flame to burn away fuzz and lint, giving a smooth appearance.</li> </ul>
<b>Polyester</b>	<ul style="list-style-type: none"> <li>• <b>Lubricated:</b> Treated with lubricant to reduce friction. Avoid thread that is oily to the touch.</li> <li>• <b>Bonded:</b> Treated with resin to increase strength. This is typically used for heavy-duty applications, such as upholstery.</li> </ul>

## Choosing Your Thread (Continued)

### Our Recommended Thread

Finesse thread is specially-designed for quilting by the Grace Company. It can be used with domestic (sewing) and quilting machines, and comes in 60 colors.

- 100% Polyester, 3-ply thread
- 1,500 yards mini-cone
- 50 wt.
- 110/18 or 100/16 quilting machine needle
- Topstitch 90/14 sewing machine needle

3283 Snow White	3293 Charcoal	2979 Rainbow	2989 Prism	2999 Cherry Blossom	3009 Deep Forest Green
3284 Pearl White	3294 Midnight Blue	2980 Sunny Spring Day	2990 Tropical Sunset	3000 Candy Apple	3010 Vintage Turquoise
3285 Light Wool	3295 Obsidian	2981 Strawberry Lemonade	2991 Aurora Lights	3001 Pomegranate	3011 Seaside Teal
3286 Ice Blue	3296 Marigold	2982 Pastels	2992 Mango Salad	3002 Dusk Rose	3012 Ocean Wave
3287 Pink Rose	3297 Leafy Green	2983 Raspberry Ice	2993 Camp Fire	3003 Cotton Candy	3013 Bright Blue Sky
3288 Lilac	3298 Blue Sapphire	2984 Circus Tent	2994 Mountain Jungle	3004 Tangerine Punch	3014 Lavender Blossom
3289 Light Sand	3299 Magenta	2985 Twilight Pink	2995 Desert Flower	3005 Grapefruit	3015 Amethyst
3290 Thicket Brown	3300 Amber	2986 Mauve Orchid	2996 Primary School	3006 Lemon Zest	3016 Mountain Mist
3291 Desert Tan	3301 Royal Purple	2987 Blueberries	2997 Mojito	3007 Light Spearmint	3017 Riverbed Slate
3292 Smokey Quartz	3302 Ruby Red	2988 King of Atlantis	2998 Florence	3008 Green Tea	3018 Canyon Shale

## Choosing Your Fabric and Batting

### **Fabric**

Some fabrics are not recommended for use with the quilting machine. Thick fabrics, such as denim or leather, have a lot of resistance that can bend or snap a needle, and misalign or break internal machinery. When quilting, avoid any fabrics that are difficult to pierce, and take care that the fabric layers of the quilt are well balanced .

### **Batting**

To choose the best batting for your project, consider the look and feel of the quilt that you're going for. Batting thickness is measured by its loft. A low loft batting is thinner and lighter, ideal for a quilt with a flatter appearance. High loft batting should be used if a fluffy, full quilt is the goal.

Typically, wool batting is the thickest batting while bamboo is the lightest. Wool provides the most warmth, followed by polyester, and then cotton.



## Troubleshooting Guide

Issue	Cause(s)	Solution
<b>Machine won't turn on.</b>	Loose cables	Check that all cables are securely plugged in (page 25).
	Machine is not turned on	Check power button is pressed down on right side (page 25).
	If problem persists, please contact a Grace Company support technician. Call <b>(800) 264-0644</b> .	
<b>Stitches are skipped.</b>	Damaged needle	Check needle (page 60).
	Machine improperly threaded	Check that all tensioners and guides were threaded correctly (page 33).
	Bobbin wound or threaded incorrectly	Check that the bobbin was inserted the correct direction in the case (page 31).
	Incorrect thread tension	Adjust top thread tension (page 50). Adjust bottom thread tension (page 31).
	Hopping foot incorrect distance from needle plate	Check hopping foot height distance with height tool (page 63).
	If problem persists, please contact a Grace Company support technician. Call <b>(800) 264-0644</b> .	
<b>Thread is breaking.</b>	Damaged needle	Check needle (page 60).
	Incorrect thread tension	Adjust top thread tension (page 50). Adjust bottom thread tension (page 31).
	Machine improperly threaded	Check guides and tensioners for accidental double-wrapping (page 33).
	Stitching in place too long	Keep machine moving to avoid stitch build-up in one place, or switch to regulated precise quilting mode (page 41).

Issue	Cause(s)	Solution
Thread is breaking.	Bobbin inserted incorrectly	Check bobbin is the correct direction in the case and inserted firmly (clicked) into the machine (page 31).
	Debris on tension discs	Clean the machine (page 57).
	Burred bobbin	Check bobbin for sharp edges. Contact your dealer to replace if needed.
	Needle plate is rubbing needle	Check that needle plate is centered and does not hit needle (page 68).
	If problem persists, please contact a Grace Company support technician. Call <b>(800) 264-0644</b> .	
Machine is running loud.	Machine and/or hook assembly needs oiling	Oil the machine and hook assembly (page 57).
	Bobbin winder is on	Check that bobbin cam is off (away from bobbin stand).
	If problem persists, please contact a Grace Company support technician. Call <b>(800) 264-0644</b> .	
Thread is bunching up in hook assembly (bobbin case area).	Bobbin wound or threaded incorrectly	Check that the bobbin was threaded correctly and inserted the correct direction in the case (page 31).
	Machine improperly threaded	Check that all tensioners and guides were threaded (page 33).
	Incorrect thread tension	Adjust top thread tension (page 50). Adjust bottom thread tension (page 31).
	Bobbin case has damaged or missing spring	Check inside bobbin case to see spring. Contact your dealer to replace if needed.
	If problem persists, please contact a Grace Company support technician. Call <b>(800) 264-0644</b> .	

## Index

## Index

## Symbols

2.5 mm T-handle Allen wrench.....	21, 23, 72
2 mm T-handle Allen wrench.....	78
3 mm T-handle Allen wrench.....	63, 75
4 mm T-handle Allen wrench	13, 16, 17, 20, 21, 23, 72
5 inch touch display.....	19

## A

assembly.....	12
---------------	----

## B

basting.....	45
batting.....	88
bobbin.....	29, 31
bobbin cam.....	30, 62
bobbin cam adjustment.....	62
bobbin case.....	31
bobbin level indicator.....	49
bobbin tension.....	32
bottle.....	57
bottom carriage.....	23
bottom thread tension.....	32

## C

cleaning.....	57
controls.....	28, 40
cruise quilting mode.....	43

## D

defaults.....	27
dimensions.....	5
display.....	19
display cable port.....	8, 19
display clip port.....	8, 19

## E

electrical.....	2, 5, 25
encoder.....	21, 23, 72
encoder port.....	8, 22, 24

encoder spring.....	72
---------------------	----

## F

fabric.....	88
features.....	5
firmware.....	71
flat-head screwdriver.....	68, 75, 78

## G

grounding instructions.....	3
guide loops.....	30, 35

## H

handlebar adjustment.....	17
handlebar assembly.....	17
handlebar controls.....	28, 40
hand wheel.....	6
hook assembly.....	7, 75, 78
hook holder.....	75
hopping foot.....	63
hopping foot height tool.....	63
hours run.....	54

## I

included parts and tools.....	9
-------------------------------	---

## L

lamp.....	7
large thread tensioner.....	50
layout.....	6
left-handed.....	28
leg cover.....	16
lint brush.....	57
long encoder cable.....	

## M

machine dimensions.....	5
machine layout.....	6
machine settings.....	27
machine specifications.....	5
maintaining the machine.....	55

# Appendix

## Index (Continued)

- measurements ..... 52
- metric ..... 28
- N**
- needle ..... 60, 83
- needle diagram ..... 84
- needle groove ..... 84
- needle magnet ..... 60
- needle plate ..... 68
- needle scarf ..... 84
- needle size ..... 83
- O**
- oiling ..... 56, 57
- out-of-the-box ..... 12
- P**
- parts ..... 9
- parts of machine ..... 6
- plastic base ..... 16
- power cable ..... 25
- power cable retainer ..... 25
- power port ..... 8, 25
- power switch ..... 8, 25
- precise sewing mode ..... 41
- preferences ..... 27
- processed threads ..... 86
- Q**
- Quilt Motion tablet port ..... 8
- R**
- right-handed ..... 28
- S**
- safety instructions ..... 2
- SBHCS screw M6 x 14 mm ..... 16, 20
- SBHCS screw M6 x 20 mm ..... 13
- screen installation ..... 19
- screwdriver ..... 68, 75, 78
- Settings menu ..... 27
- sewing mode: basting ..... 45
- sewing mode: cruise ..... 43
- sewing mode: precise ..... 41
- shoulder bolt M6 ..... 13
- specifications ..... 5
- stitch count ..... 54
- stitches per centimeter ..... 28
- stitches per inch ..... 28
- stitches per minute ..... 47
- support ..... 12, 89
- System Information screen ..... 28
- T**
- thread ..... 29, 33, 85
- thread cutter ..... 30
- threading the machine ..... 33
- thread size ..... 86
- thread stand ..... 20, 30, 35
- thread strength ..... 33
- thread tension ..... 32, 50
- timing machine ..... 78
- timing spacer ..... 78
- total hours ..... 54
- total stitches ..... 54
- track run time ..... 54
- track stitch count ..... 54
- troubleshooting guide ..... 89
- U**
- units ..... 28
- USB connector port ..... 8
- W**
- wheel covers ..... 16
- wheels ..... 13
- wheel support assembly ..... 13
- winding a bobbin ..... 29
- winding cam ..... 30, 62
- Y**
- yank test ..... 33
- Z**
- zip tie .....  
zip tie mount .....

**The Grace Company**  
**2225 South 3200 West**  
**Salt Lake City, UT 84119**  
**Phone: 1-800-264-0644**  
**Fax: 801-908-8888**  
**[www.graceframe.com](http://www.graceframe.com)**

