

“Select & Sew” Power Placement

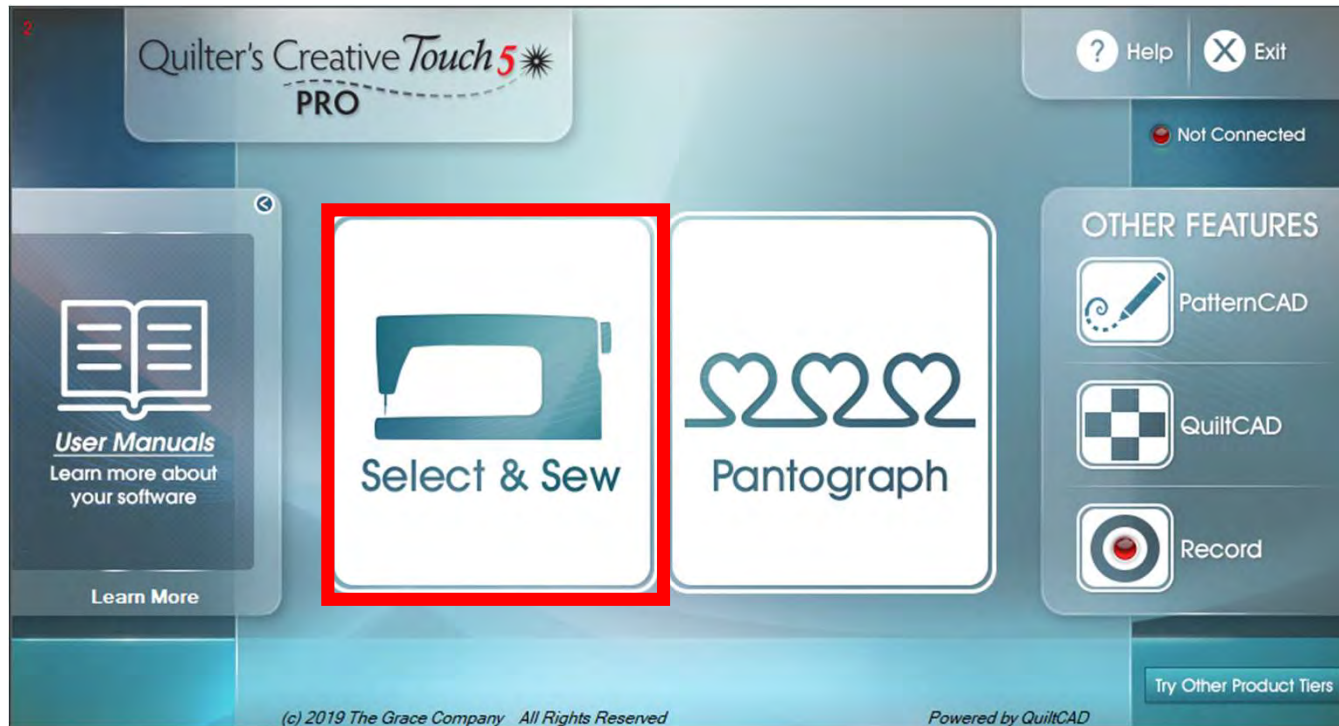

“Select & Sew” opens “Power Placement” where you can customize your quilting for each quilt block or pieced shape on your quilt. Use the different placement methods to accurately place designs to create a one-of-a-kind customized quilt.

“Select & Sew” Power Placement continued. . .

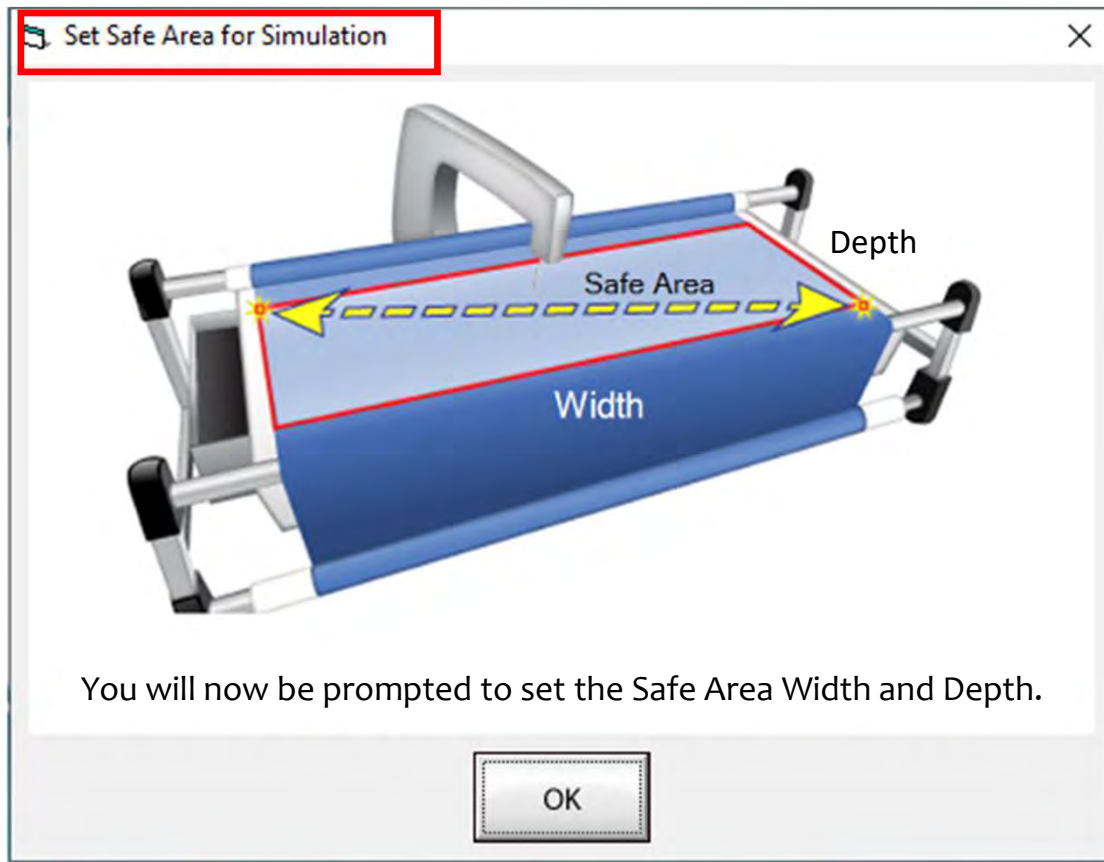

Whenever you open up QuiltMotion/QCT5 you are asked to set your “Safe Area” when you open in simulation mode, (simulation mode machine is not hooked up to tablet) the safe area is preset. Click on OK and continue in simulation mode.

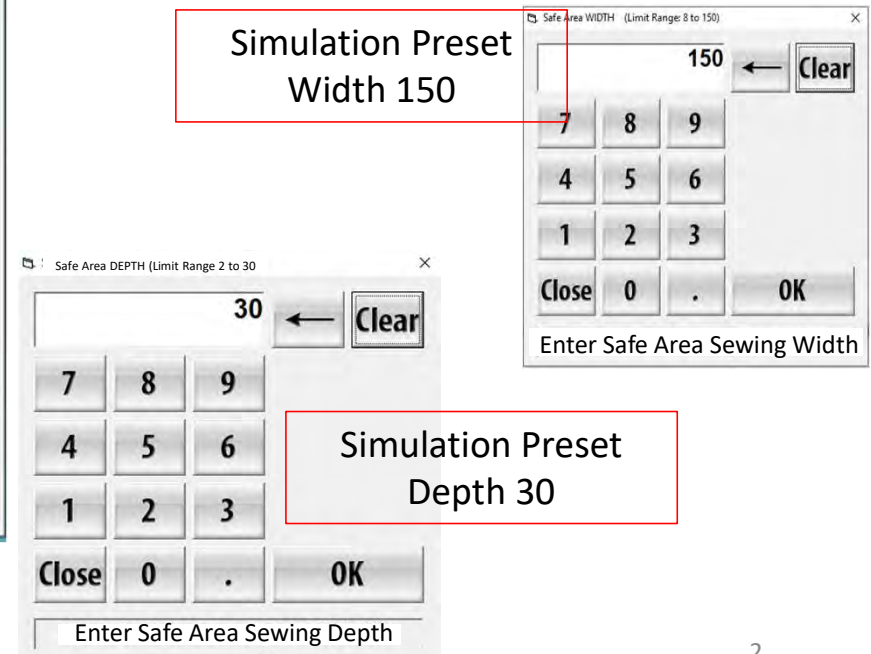

“Select & Sew” Power Placement continued. . .

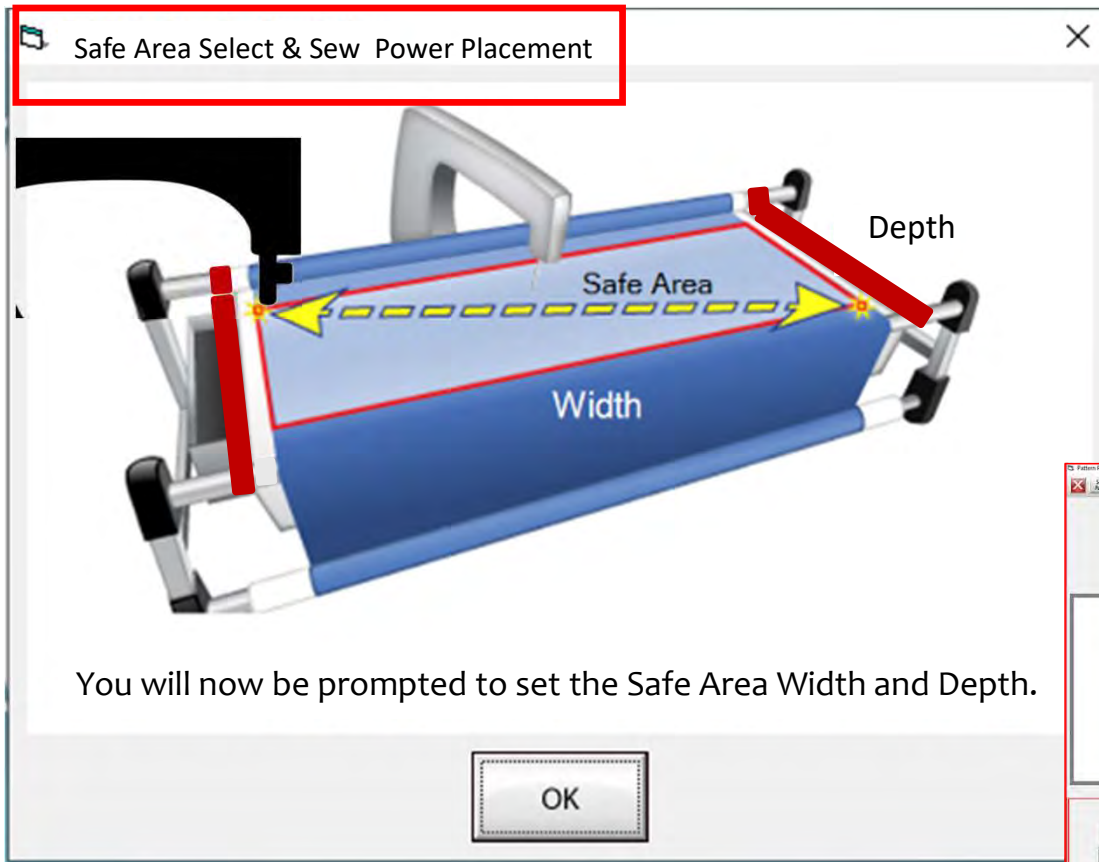

The “Safe Area” is your “quiltable,” quilting area on your quilt top. Move your machine to the “TOP LEFT of your Quilt Top corner (edge) and tap on the screen in the “Click to Set the Safe Area.” You have now set your “Safe Area” WIDTH.

*Note: Select & Sew Power Placement Width (the width of your “Quilt Top” if you are putting the size in manually.

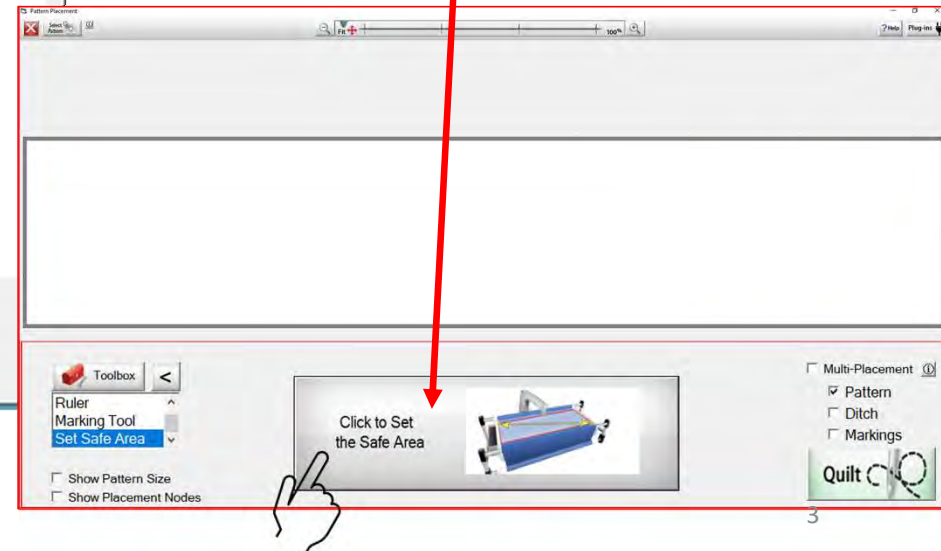

“Select & Sew” Power Placement continued. . .

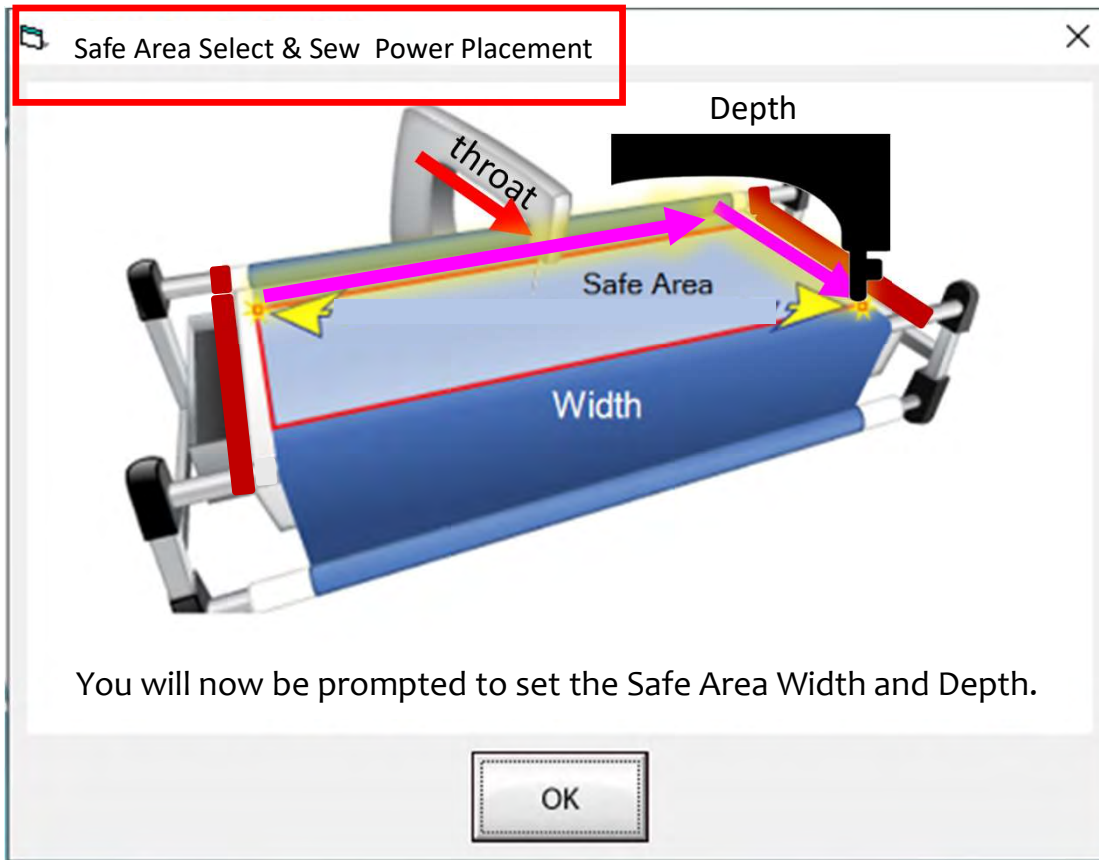

*Note: Select & Sew Power Placement Depth (the Depth of your “Machine Throat” if you are putting the size in manually.

“Safe Area” “DEPTH” is your “quiltable,” quilting area determined by the arm (throat length) of your machine. Move your machine the width of the quilt top to the right edge, then move the machine as far forward as you can towards the front of the frame as far forward as the machine will extend to the “BOTTOM RIGHT” of your Quilt Top (edge) and tap on “Click to Set the Safe Area” on the screen.

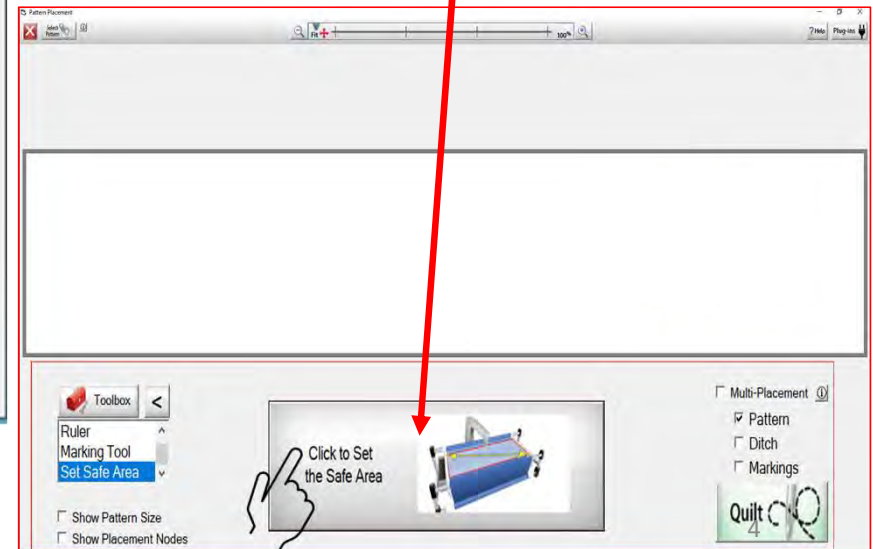

“Select & Sew” Power Placement

“Select & Sew” opens “Power Placement” which helps you customize your quilting for each quilt block or pieced shape on your quilt. Use the different placement methods to accurately place designs to create a one-of-a-kind customized quilt.

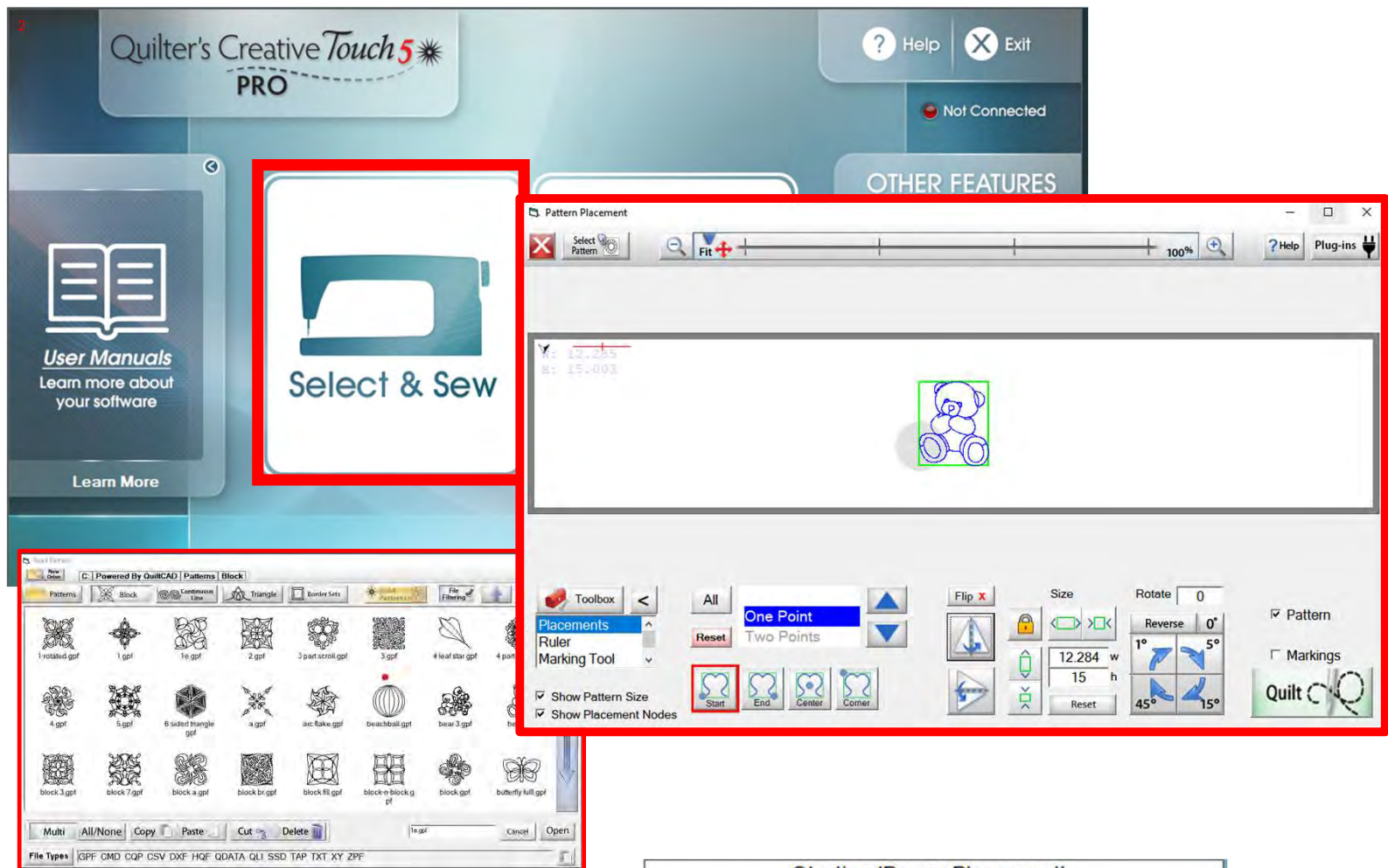

“Select & Sew” Power Placement Screen

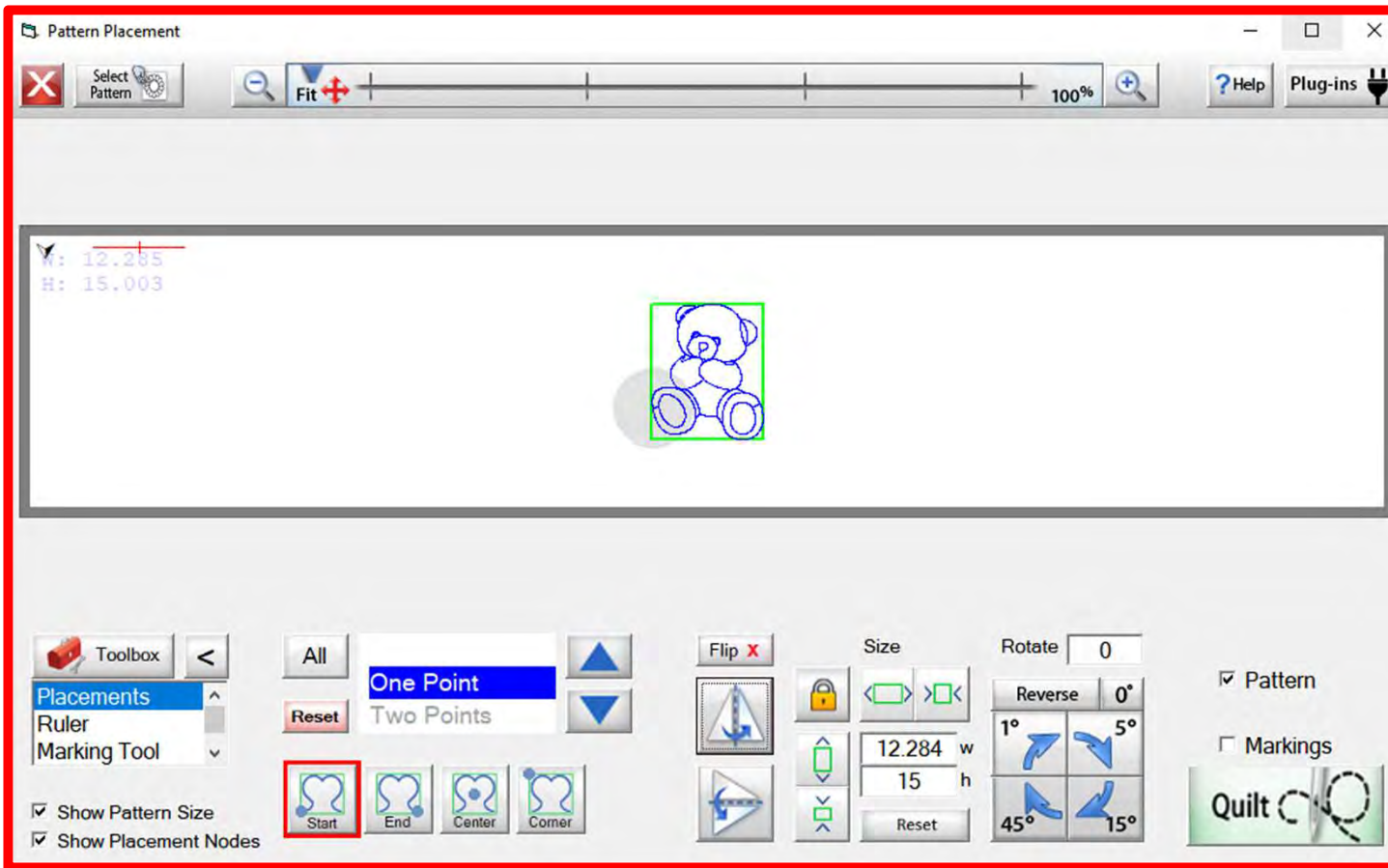

Starting 'Power Placement'..

This section is all about the “Select & Sew” power placement screen and the features of the screen. We will also show you the different power placement methods and how and when you would use them to create a one-of-a-kind quilt.

“Select & Sew” Select Pattern

“Select Pattern” from Block patterns/designs, Continuous Line, Triangles, and Borders there are several choices to choose from.

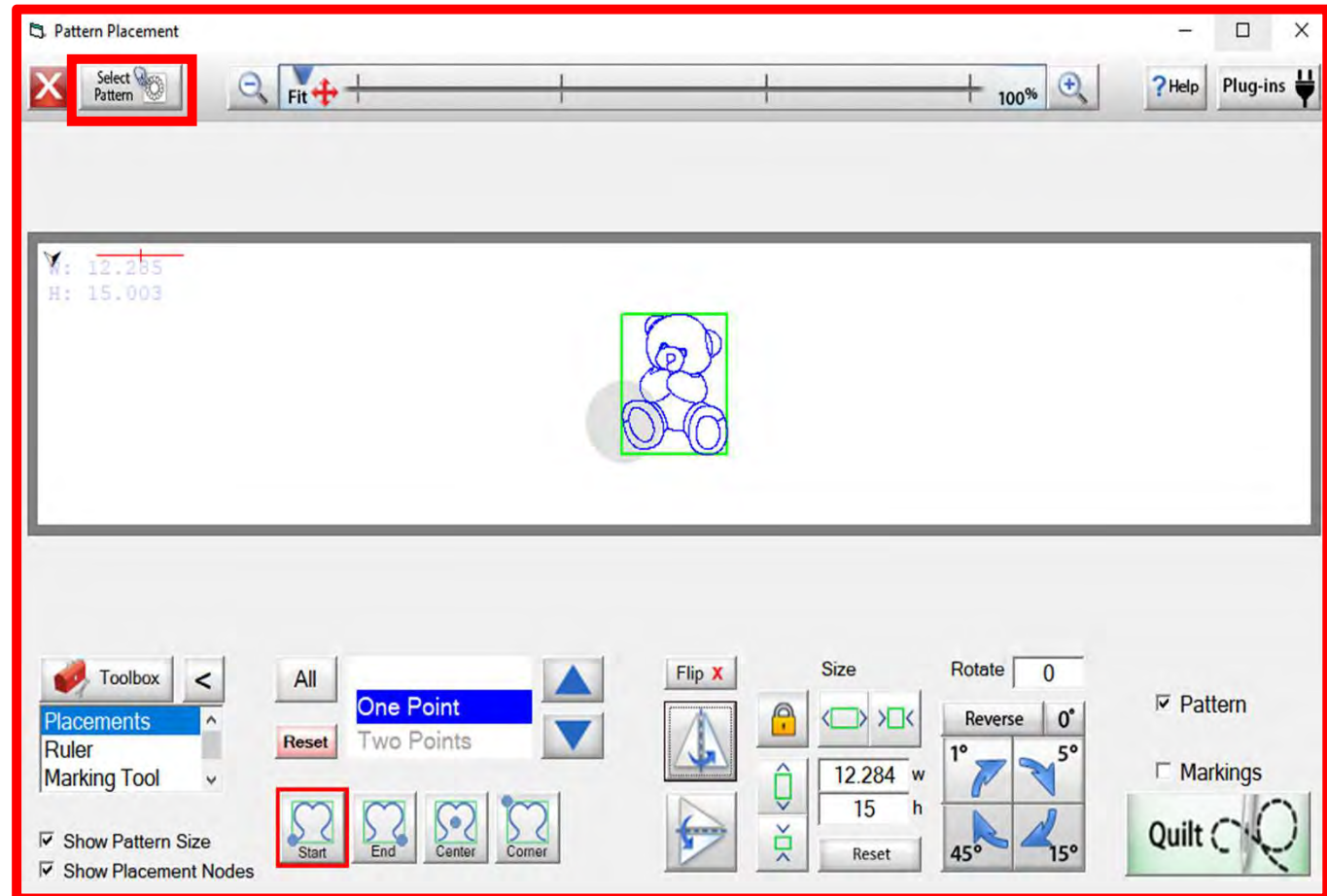

Block Line Patterns/Designs

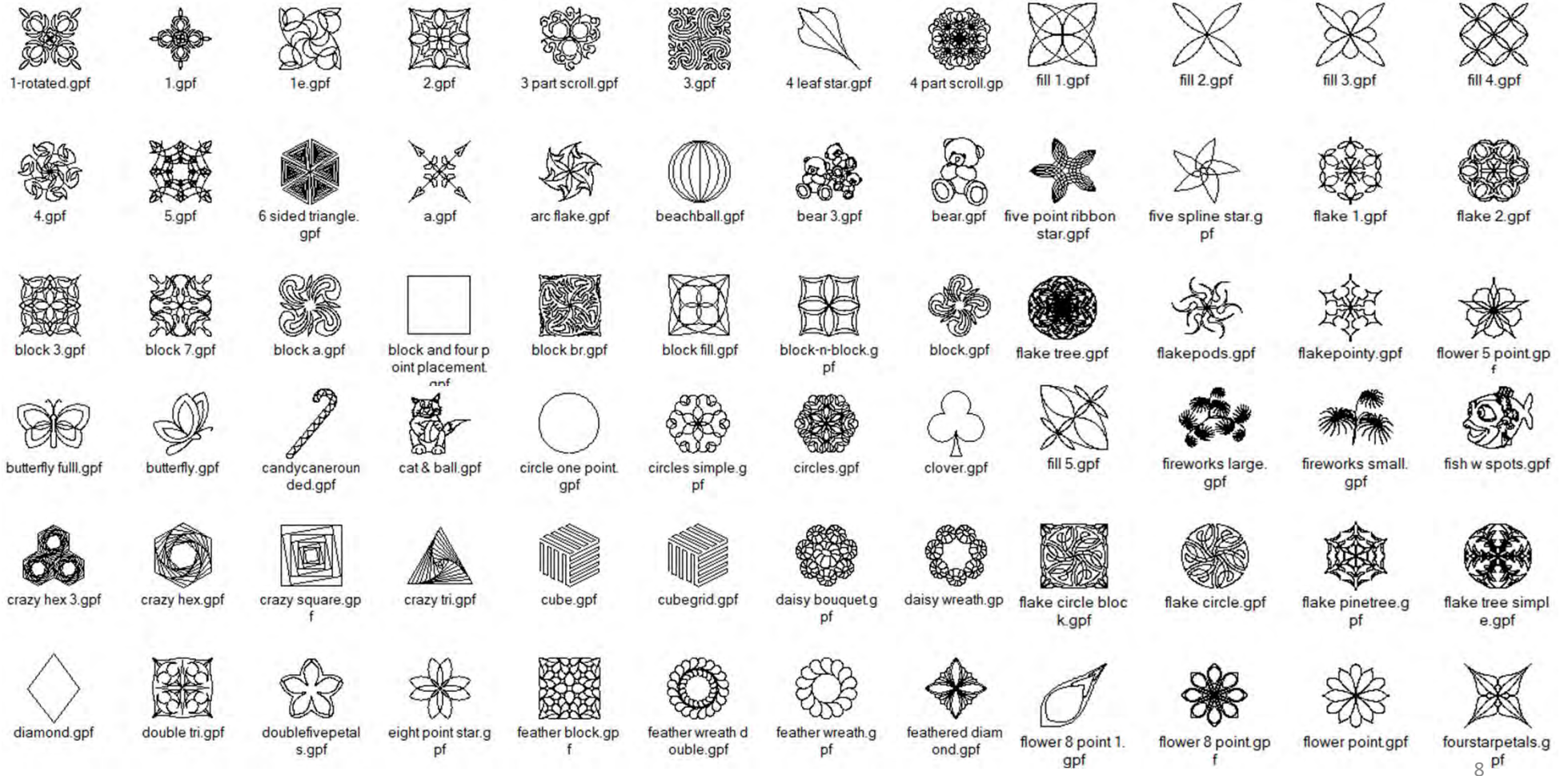

Block Line Patterns/Designs

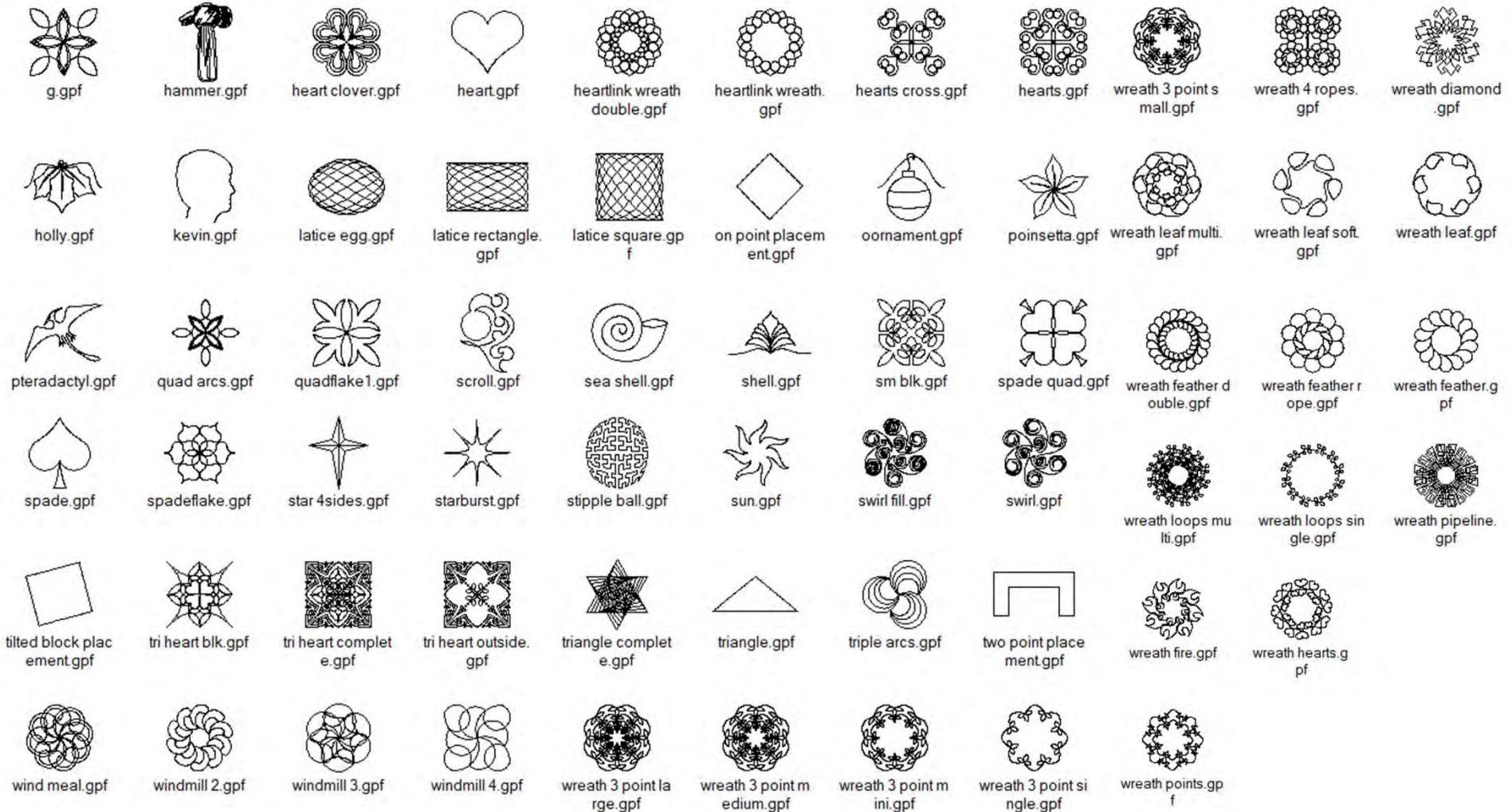

Continuous Line Patterns/Designs

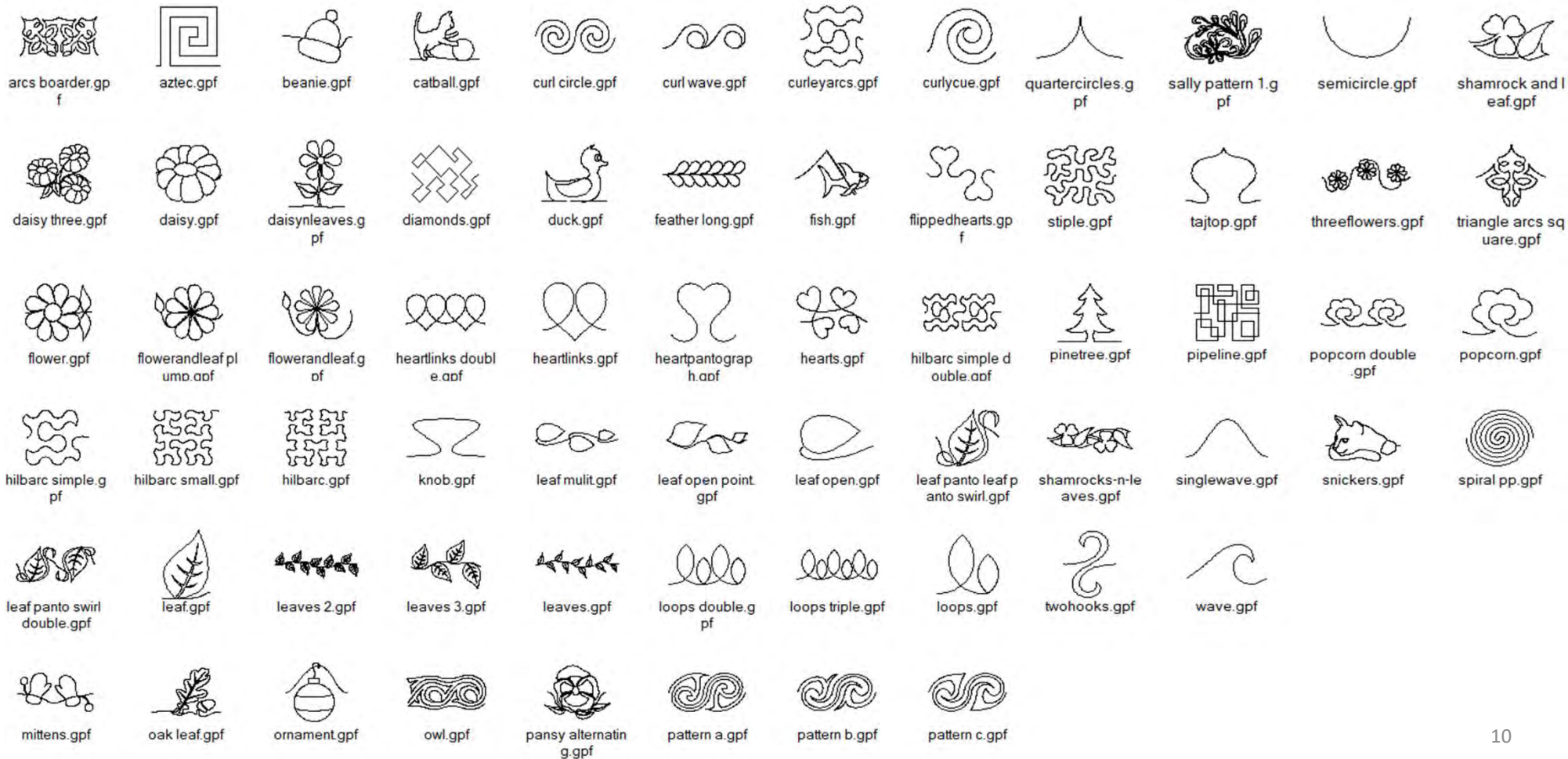

Triangle Patterns/Designs



1.gpf



10.gpf



11.gpf

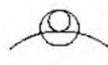

13.gpf

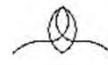

14.gpf



15.gpf

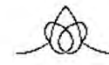

1a2.gpf



2.gpf



3.gpf



3a1.gpf



4.gpf



5.gpf



8.gpf



9.gpf

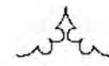

arc1.gpf



arc4.gpf



arcs.gpf



bubbles.gpf



feather triangle.gpf



fern.gpf

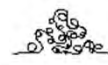

fish bubbles.gpf



full.gpf



hearts.gpf



leaf triangle.gpf



seaweed.gpf



shell.gpf



splines1.gpf



splines2.gpf



splines5.gpf



tri feather.gpf



triangle 1.gpf



triangle 10.gpf



triangle 2.gpf

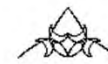

triangle 3.gpf



triangle 4.gpf



triangle 5.gpf



triangle 6.gpf



triangle 7 simple.gpf



triangle 7.gpf



triangle 8.gpf



triangle 9.gpf

Border Sets Patterns/Designs



curlycue.gpf



curlycuecorner.
gpf



duck corner.gpf



duck.gpf



fishfishing.gpf



fishfishingcorner
.gpf



heartborder.gpf



heartcorner.gpf

Power Placement Screen

Pattern Placement

Select Pattern

Fit + 100%

Help Plug-ins

You can reposition your design by moving the machine slightly and re-tapping on the nodes to reposition.

W: 15
H: 15

Pattern/design size

Node

Move machine to upper point of triangle block and tap on node.

Node

Move machine to bottom left of triangle and tap on the node.

Node

Move machine to bottom right point of triangle and tap on the node.

Toolbox

Tilted Block
Triangle
On Point

Flip X

Margins
0 H
0 V
Reset

Stretch Fit

Pattern
Ditch
Markings

Quilt

Show Pattern Size
 Show Placement Nodes

Power Placement Screen

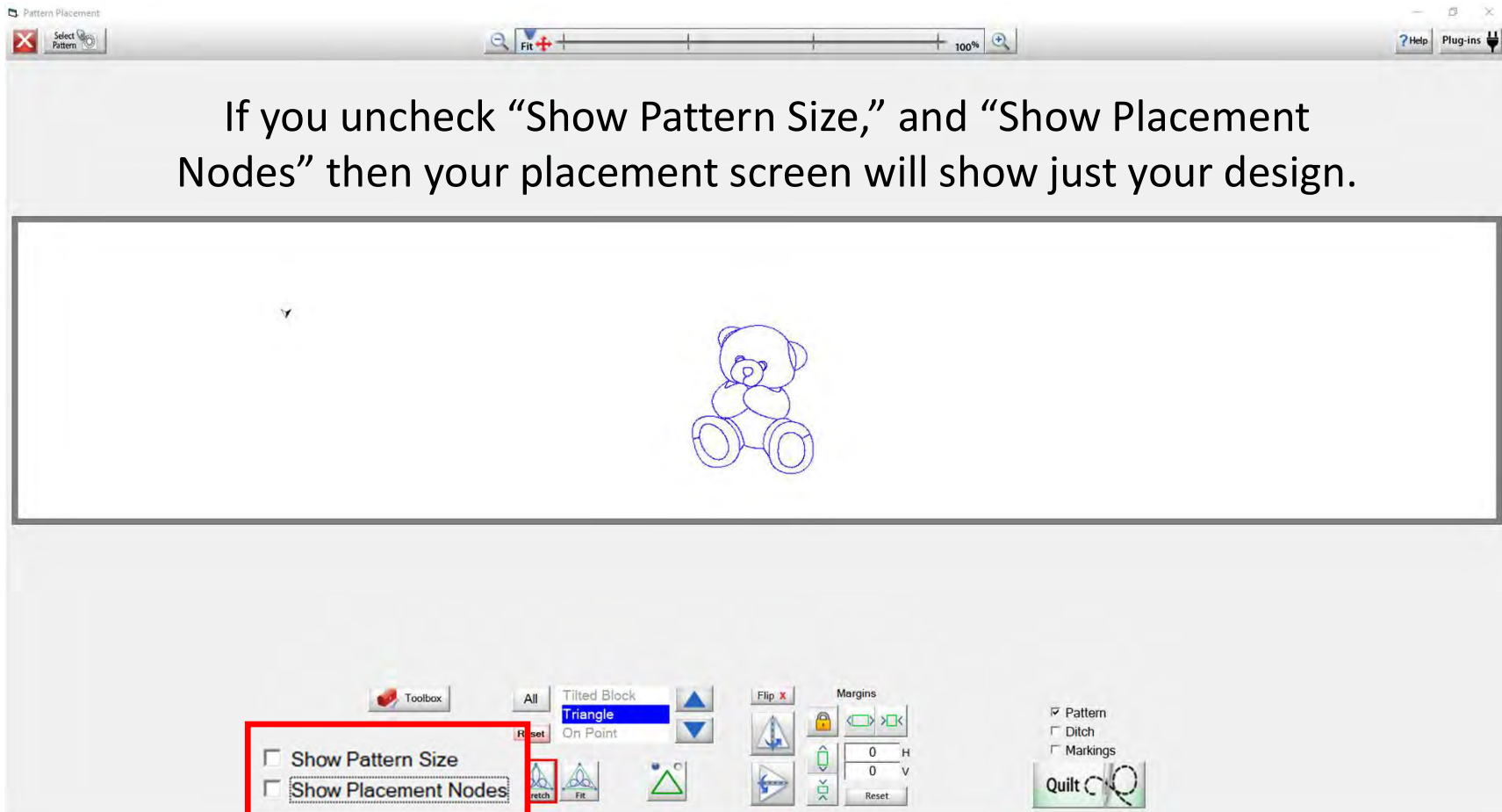

Zoom In & Zoom Out

At the top of your placement screen is your

zOOM OUT

zOOM IN

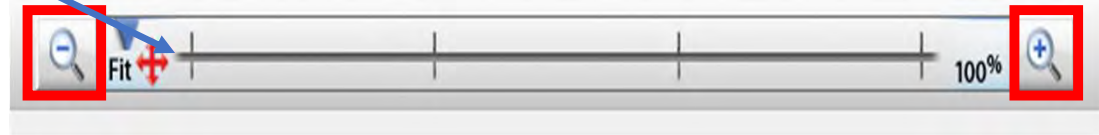
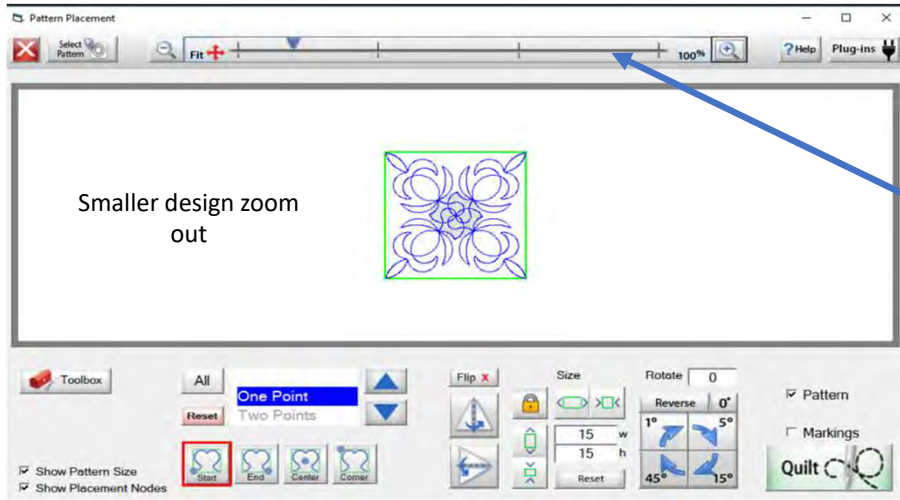

Using the + or – you can zoom in for a closer look at your design or zoom out to look at the area surrounding your pattern/design. Clicking on the (+) will zoom in for a closer look. Clicking on the (-) will zoom out.

Clicking on “FIT” will change your pattern/design back to the original size to fit your tablet screen.

For an accurate placement of your pattern/design inside your block use the marking tool, which is our next feature, along with the zoom out.

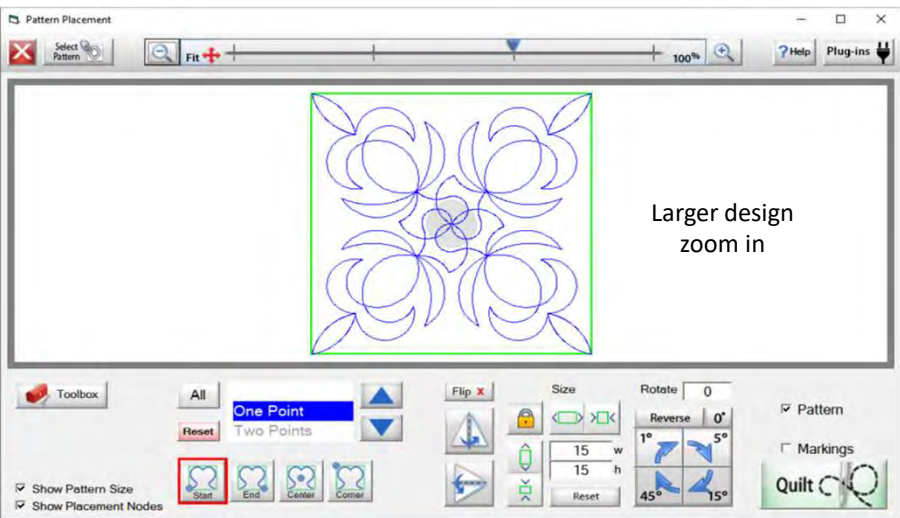

“Select & Sew” Select Pattern

“Help” opens help files you can read and print off.

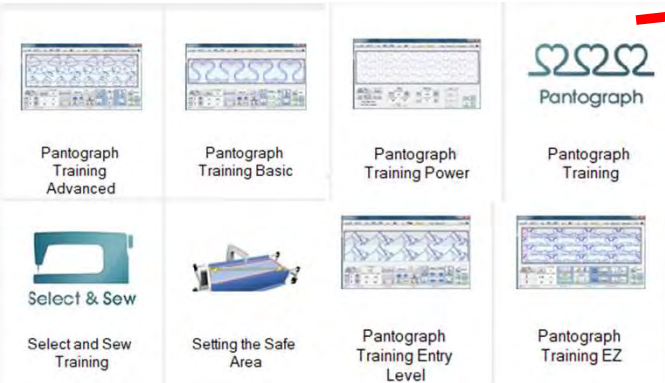
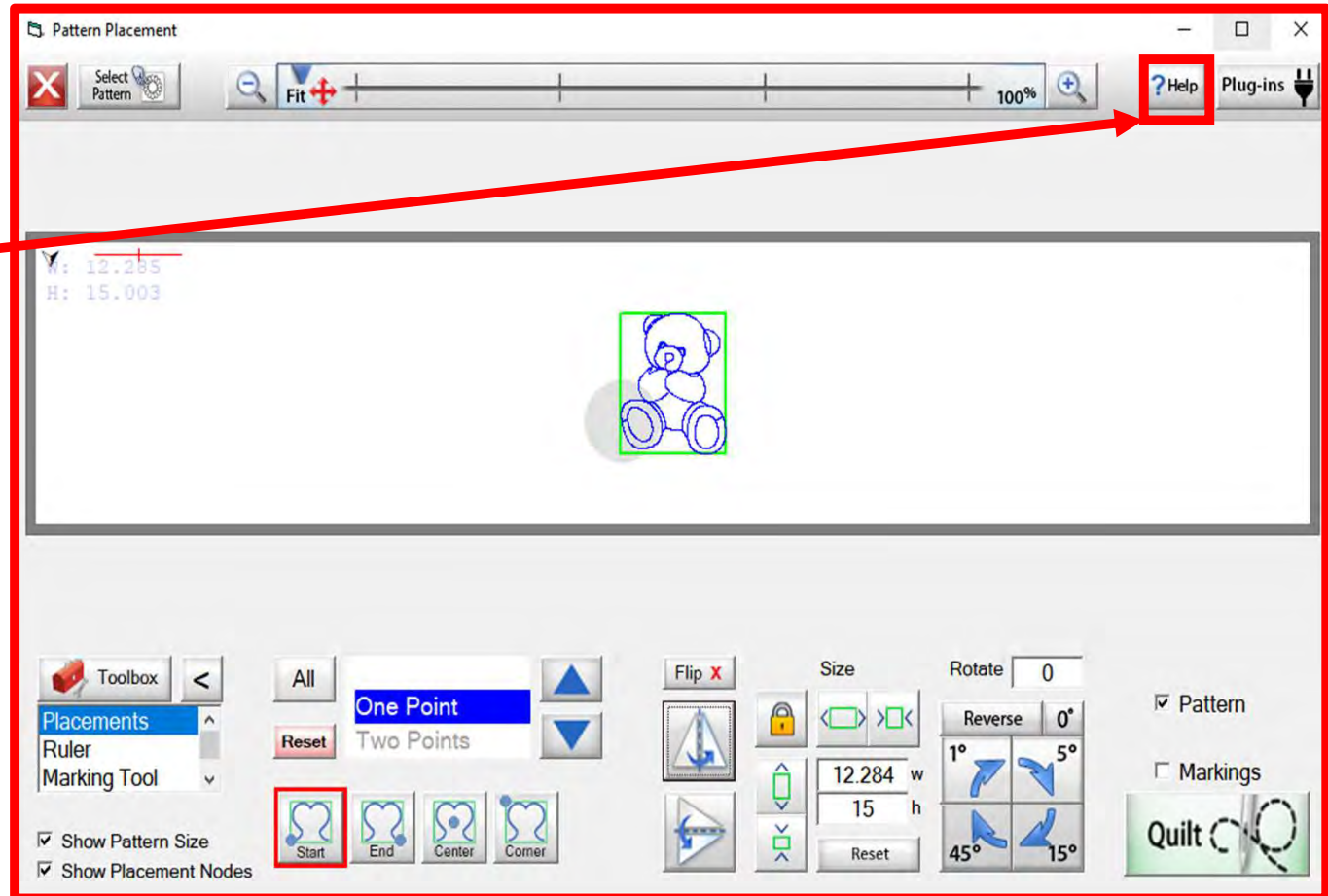

More coming...

“Select & Sew” Select Pattern

“Plug-Ins” have “Batch Import” which will allow you to import purchased designs. The “Marking Tool” helps you place designs with accuracy. Marking tool will be discussed when we go over the Toolbox features.

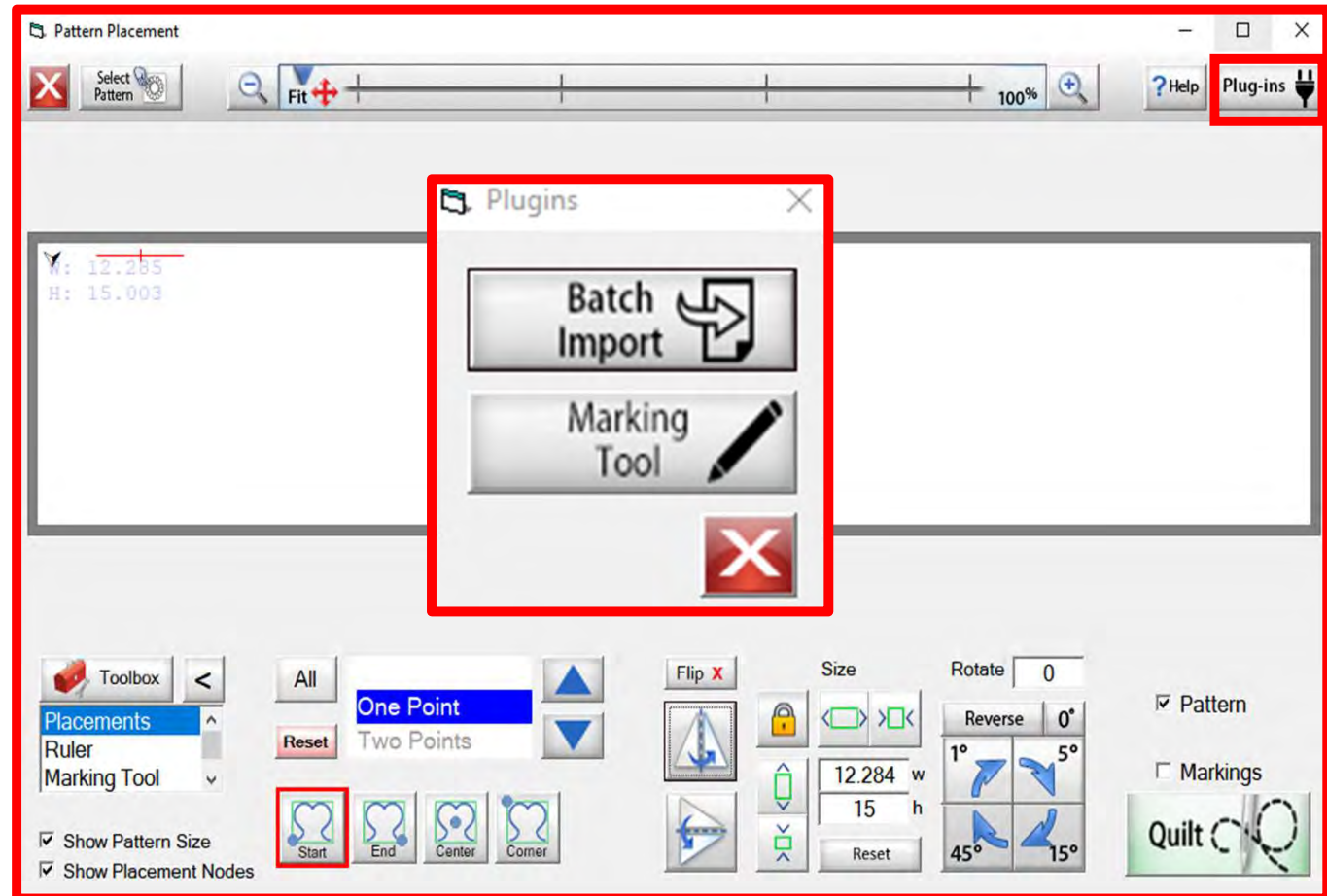

Plug-Ins Batch Import

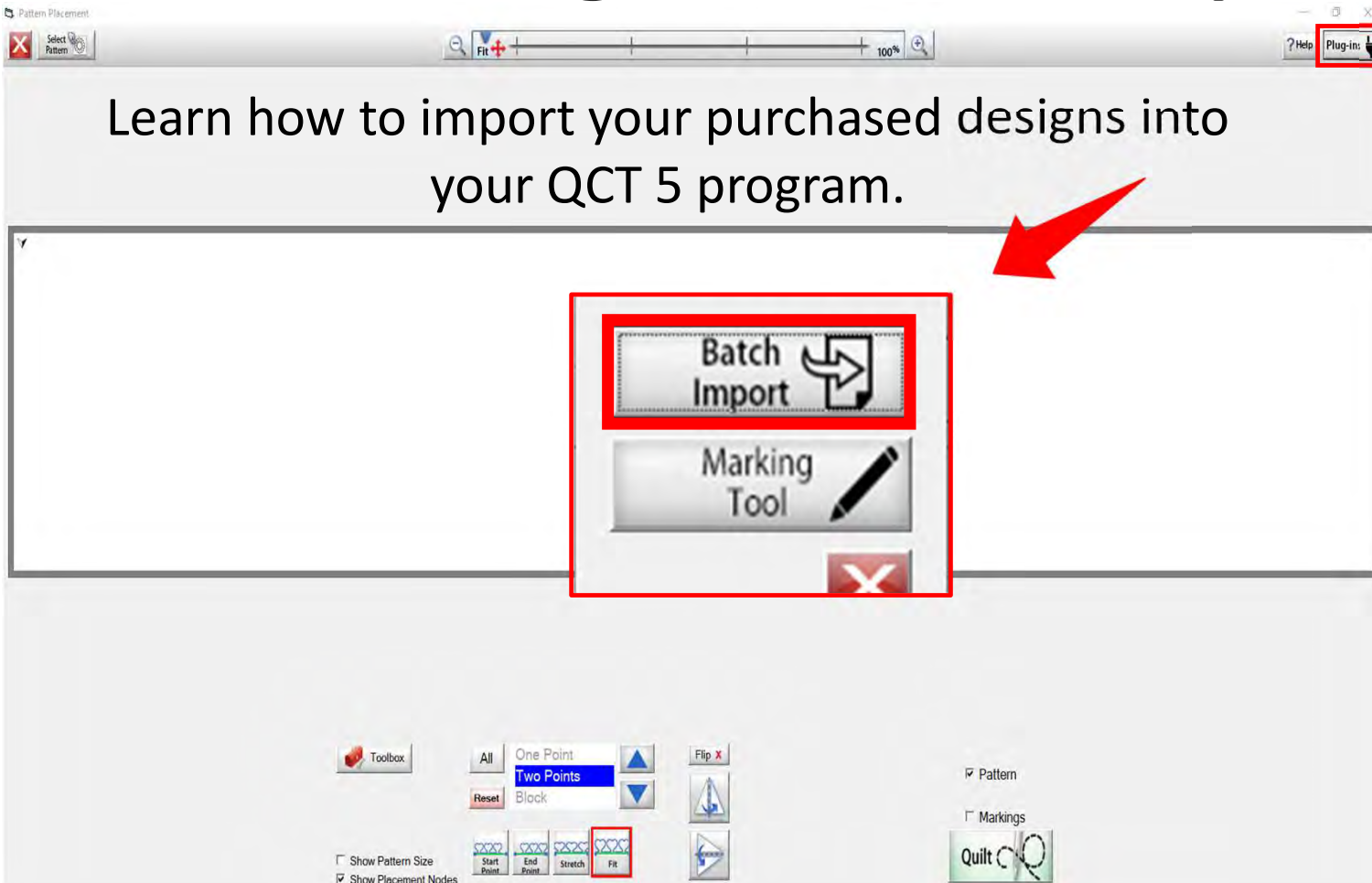

Click

What quilter doesn't like to shop? We like to shop for fabrics, quilt patterns, quilting accessories (rulers etc.) and now we can shop for digital quilting designs. These are purchased designs we can use to enhance your already beautiful top into a spectacular one-of-a-kind QUILT.

Plug-Ins Batch Import continued. . .

Websites for Digitized Patterns

Intelligent Quilting	www.intelligentquilting.com
Anne Bright Designs	www.annebright.com
Wasatch Quilting	www.digitizedquiltingpatterns.com
Urban Elementz	www.urbanelementz.com
My Creative Stitches	www.mycreativestitches.com
Karlee Porter	www.karleeporter.com
Quilts Complete	www.quiltscomplete.com
Legacy Quilting	www.legacyquilting.com
The Quilter's Quilter	www.thequiltersquilter.com.au/store/index.html
Munnich Design's LLC, Quilt Recipes	www.quiltrecipes.com
Designs By Vickie	www.designsbyvickie.com
House of Creations, Sharon Perry	www.houseofcreations.biz
Quilter's Niche	www.quiltersniche.com
Willow Leaf	www.willowleafstudio.com

Supported File Formats:

CMD **CQP** CSV DXF HQF QDATA **QLI** SSD TAP TXT XY...**QLI** or **CQP** suggested purchase format.

Plug-Ins Batch Import continued. . .

Once purchased, you can download the design(s) directly from the website onto your computer.
example

When you click on the (“Design Name Here”) under the download, that design is now in your downloads file on your computer.

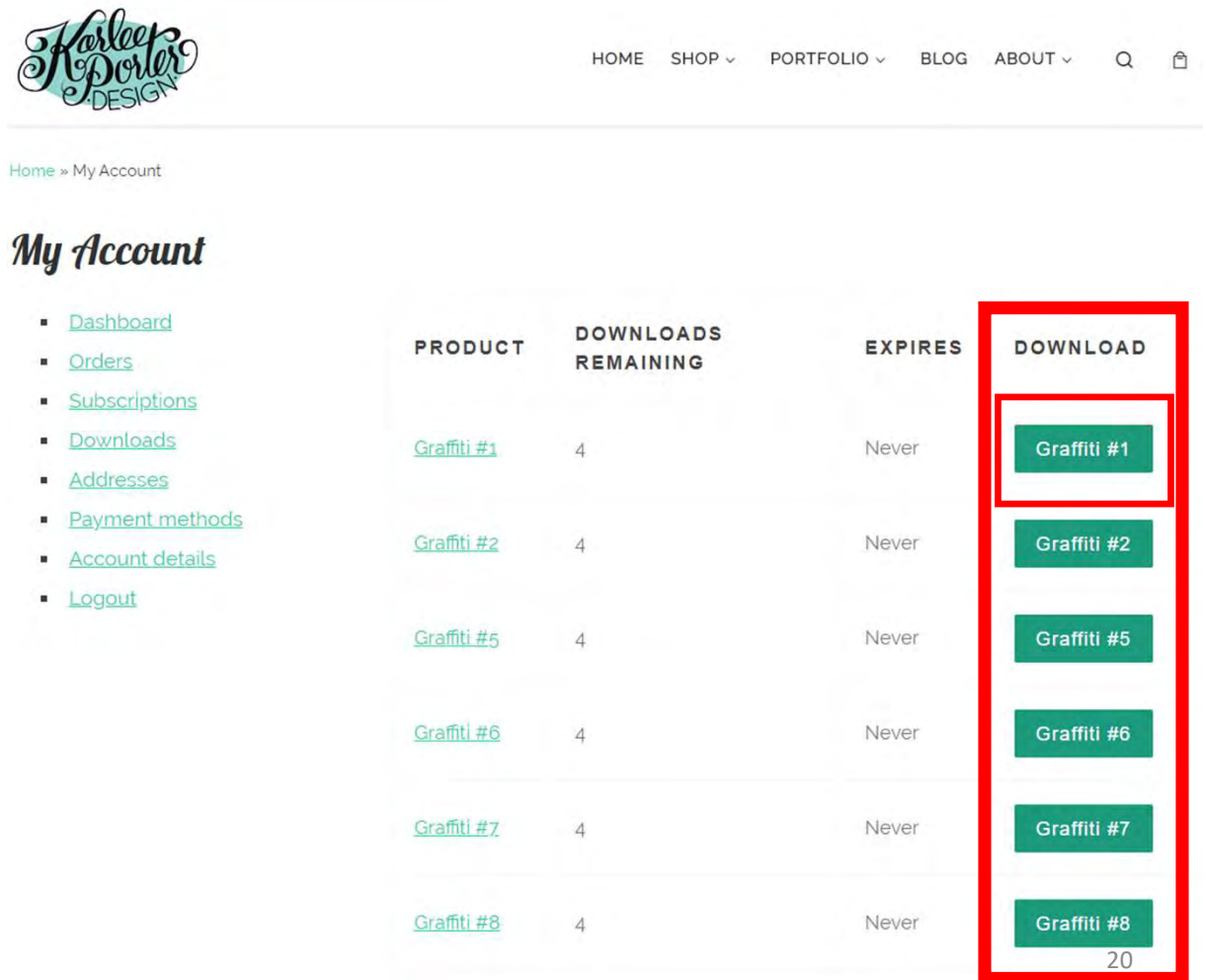

The screenshot shows the 'My Account' page for Karlee Porter Design. The page features a navigation menu with links for HOME, SHOP, PORTFOLIO, BLOG, and ABOUT. Below the navigation, there is a breadcrumb trail: Home » My Account. The main heading is 'My Account', followed by a list of account management links: Dashboard, Orders, Subscriptions, Downloads, Addresses, Payment methods, Account details, and Logout. The central part of the page displays a table of purchased products. The table has four columns: PRODUCT, DOWNLOADS REMAINING, EXPIRES, and DOWNLOAD. The products listed are Graffiti #1 through #8, each with 4 downloads remaining and an expiration of 'Never'. The 'DOWNLOAD' column contains green buttons labeled with the product names. A red rectangular box highlights the entire table area, and a smaller red box highlights the 'Graffiti #1' download button.

PRODUCT	DOWNLOADS REMAINING	EXPIRES	DOWNLOAD
Graffiti #1	4	Never	Graffiti #1
Graffiti #2	4	Never	Graffiti #2
Graffiti #5	4	Never	Graffiti #5
Graffiti #6	4	Never	Graffiti #6
Graffiti #7	4	Never	Graffiti #7
Graffiti #8	4	Never	Graffiti #8

20

Plug-Ins Batch Import continued. . .

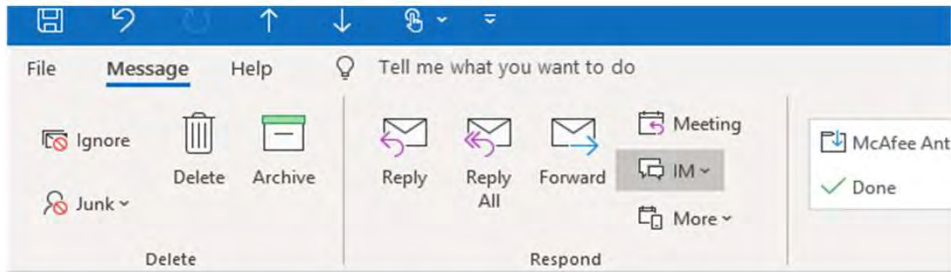

Your Karlee Porter order has been received!



KarleePorter.com <info@karleeporter.com>

If there are problems with how this message is displayed, click here to view it in a web browser.

Just to let you know — we've received your order #25292, and it is now being processed!

Downloads

Product	Expires	Download
Bethlehem Wedding Ring	Never	KP Bethlehem Wedding Ring
Bethany	Never	KP Bethany

Another way to download your purchased design(s) is through your email. An email receipt is sent to you, open the email, your designs can be downloaded from the email.

When you click on (“**design name here**”) that design is now in your download file on your computer.

Plug-Ins Batch Import continued. . .

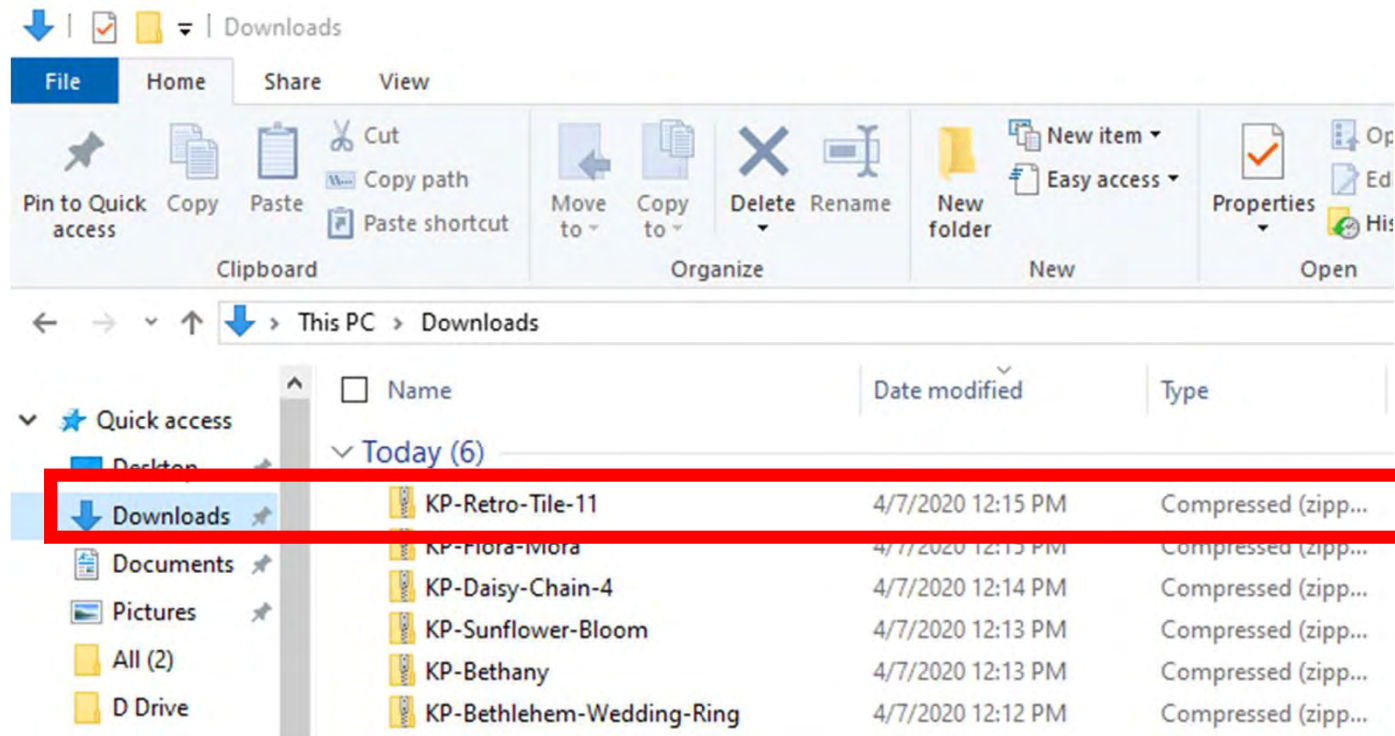

You have found your **“DOWNLOADS”** and the design you want to import. Notice it is a compressed file, this means there are several different file formats CMD CQP CSV DXF HQF QDATA QLI SSD TAP TXT XY of the design included in you purchase. Some websites will have you pick your favored file format before you purchase, other like this site will have the design in several different formats.

Plug-Ins Batch Import continued. . .

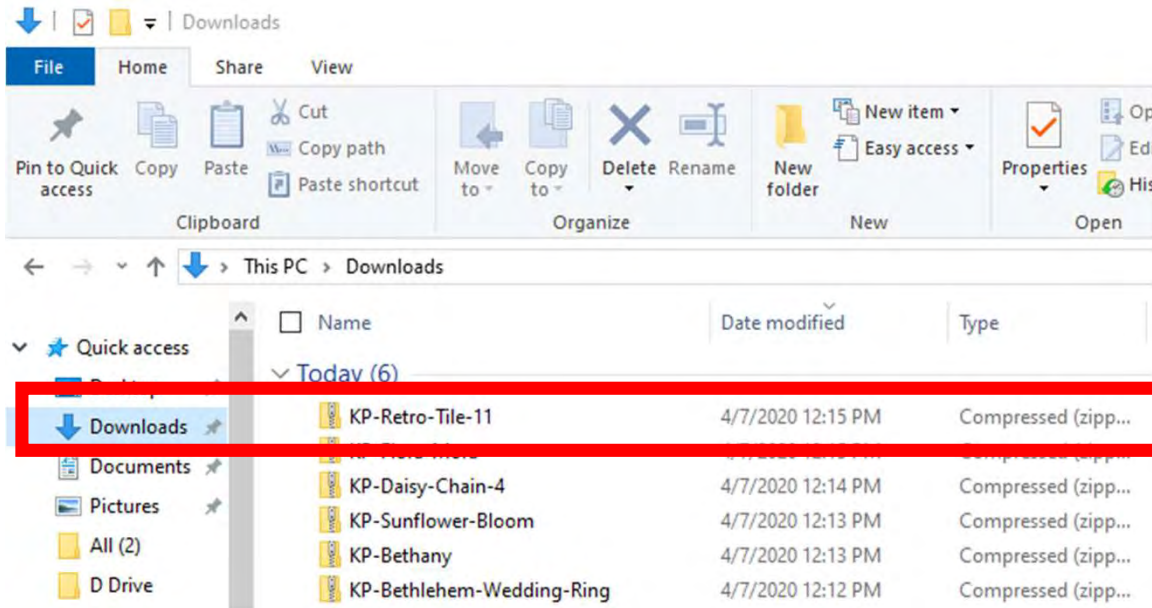

“Right click” on design file the then click on “Extract All”

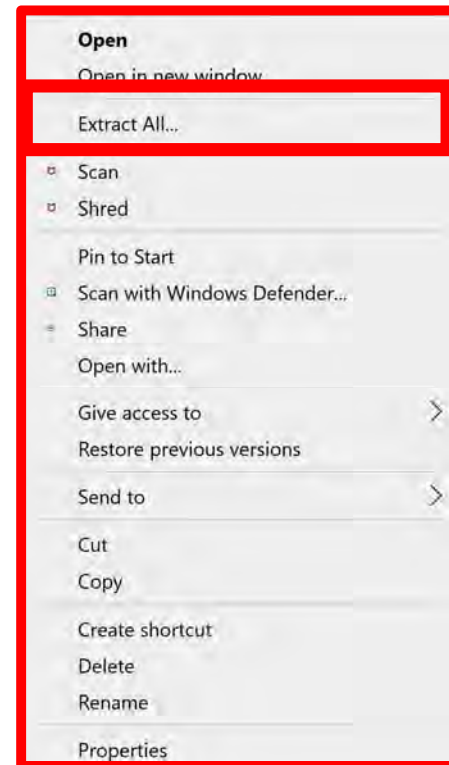

You have found your “**DOWNLOADS**” and the design you want to import. Notice it is a compressed file, this means there are several different file formats **CMD CQP CSV DXF HQF QDATA QLI SSD TAP TXT XY** of the design included in you purchase. Some websites will have you pick your favored file format before you purchase, other like this site will have the design in several different formats.

Plug-Ins Batch Import continued. . .

Click on
“Extract All”

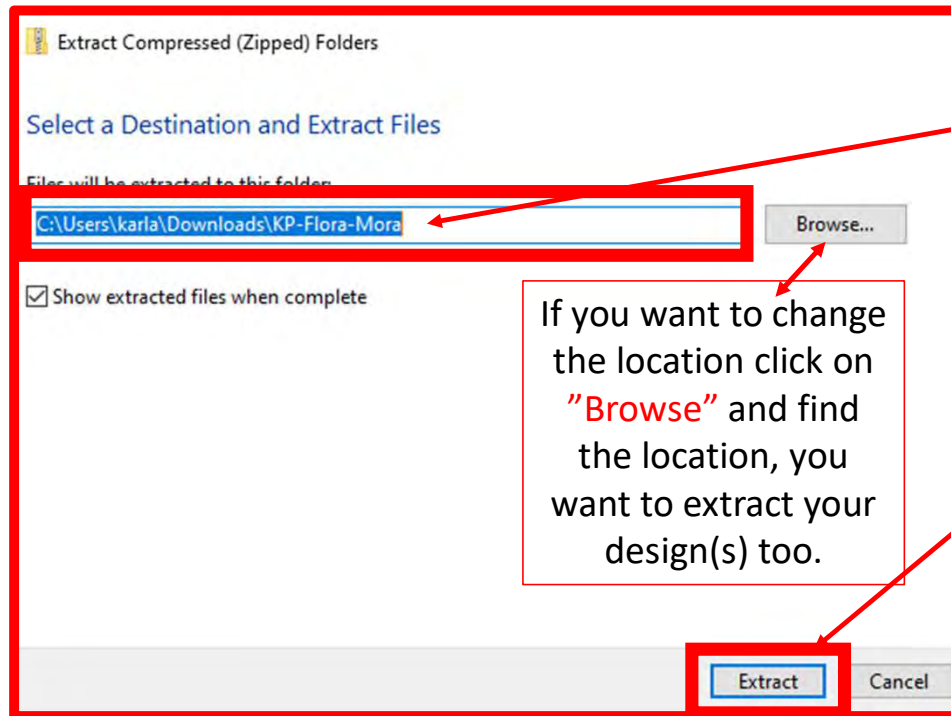

If you want to change the location click on “Browse” and find the location, you want to extract your design(s) too.

A new popup will show you where your design will be extracted too **C:\Users\karla\Downloads\KP-Flora-Mora**. Then click on **Extract** the bottom of the popup.

Repeat this same process until all your purchased designs are extracted.

Plug-Ins Batch Import continued...

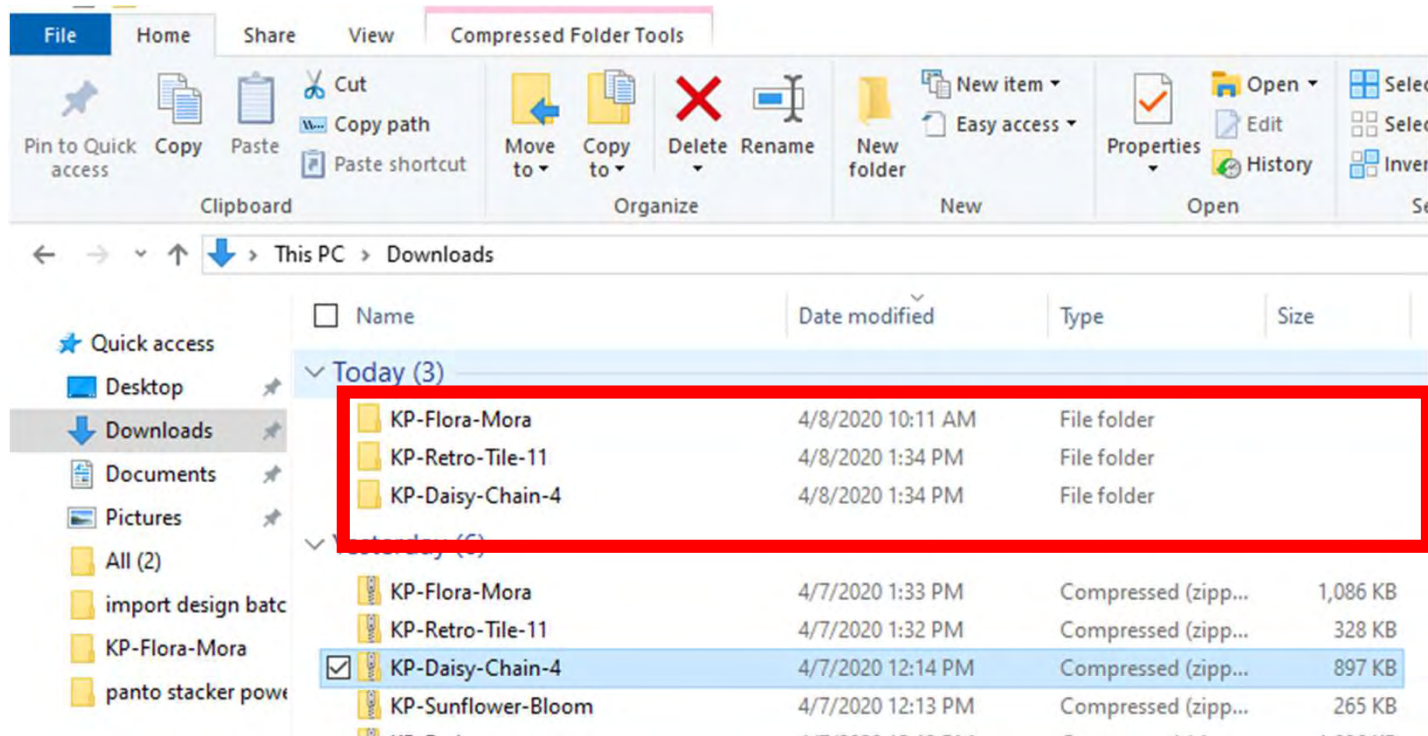

Since our files are no longer compressed, we are ready to save our design to our USB thumb drive in the desired format.

Before we save to our USB Thumb drive lets make a file folder so we can find them easily.

Plug-Ins Batch Import continued. . .

Before we copy our design(s) to our flash drive to import onto our tablet into QCT 5, we need to make a file folder and name it.

You can decide how you want to file (arrange) your designs, by designer or design type, style etc. There are several ways to arrange your designs, pick one and stick with it. **(This is a very important step and if you stick with your design filing system you won't double purchase designs or have a hard time finding one.)** This will also keep your designs separate to identify which folder it is in to import.

Plug USB Flash Drive into computer.



Find and select USB Drive (D:)

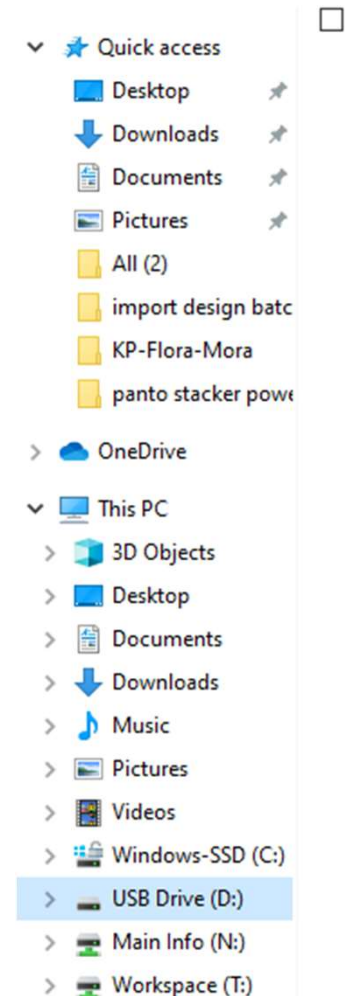

Plug-Ins Batch Import continued...

The image shows a Windows File Explorer window with the following elements:

- Navigation pane:** Shows 'USB Drive (D:)' selected and highlighted with a red box.
- Address bar:** Shows 'This PC > USB Drive (D:)'.
- File list:** Contains a table with columns for name, date, and type. A 'New folder' entry is highlighted with a red box.
- Context menu:** A right-click menu is open over the 'New folder' entry, with the 'Rename' option highlighted with a red box.
- Command bar:** The 'New folder' icon is highlighted with a red box.

1. Find and select USB Drive (D:) by selecting the D: drive we are adding a new folder to correct location

2. Click on "New Folder" this will add a new folder to your USB Drive (D:) you will see a new file folder that is named "New folder."

3. Right click on the new file folder and a popup screen will appear. Click on "Rename," we are going to rename that new folder.

Plug-Ins Batch Import continued...

The image shows a Windows File Explorer window with the 'Drive Tools' ribbon tab active. The 'New folder' button is highlighted with a red box. Below the ribbon, a file list on a USB Drive (D:) is shown. A folder named 'New folder' is selected and highlighted with a red box. A text box with the instruction '1. Now we can rename the folder.' is overlaid on the image. To the right, another File Explorer window shows the same USB drive with a folder named 'april 4 2020 kite quilt design' selected and highlighted with a red box. A text box with the instruction '2. Renamed file folder' is overlaid on this image. The 'Rename' option in the context menu of the first window is also highlighted with a red box.

1. Now we can rename the folder.

2. Renamed file folder

We are now ready to save our designs to our USB flash drive. Find your folder where you saved your extracted design.

Plug-Ins Batch Import continued...

The image shows a Windows 'Extract Compressed (Zipped) Folders' dialog box and a File Explorer window. The dialog box has a text field for the destination folder containing 'C:\Users\karia\Downloads\KP-Flora-Mora' and a checked checkbox labeled 'Show extracted files when complete'. The File Explorer window shows a list of files in the 'KP-Flora-Mora' folder, including various file formats like .ans, .cqp, .dxf, .hqf, .iqp, .pat, .plt, .ssd, .wmf, and .pdf. A red box highlights the 'Type' column in the file list.

Name	Date modified	Type	Size
KP Flora Mora.ans	4/8/2020 9:26 AM	ANS File	27 KB
KP Flora Mora.cqp	4/8/2020 9:26 AM	CQP File	56 KB
KP Flora Mora.dxf	4/8/2020 9:26 AM	DXF File	29 KB
KP Flora Mora.hqf	4/8/2020 9:26 AM	HQF File	92 KB
KP Flora Mora.iqp	4/8/2020 9:26 AM	IQP File	28 KB
KP Flora Mora	4/8/2020 9:26 AM	JPG File	236 KB
KP Flora Mora.pat	4/8/2020 9:26 AM	PAT File	5 KB
KP Flora Mora	4/8/2020 9:26 AM	Adobe Acrobat D...	246 KB
KP Flora Mora.plt	4/8/2020 9:26 AM	PLT File	50 KB
KP Flora Mora.ssd	4/8/2020 9:26 AM	SSD File	52 KB
KP Flora Mora	4/8/2020 9:26 AM	Text Document	48 KB
KP Flora Mora	4/8/2020 9:26 AM	WMF File	14 KB
KP Flora Mora2	4/8/2020 9:26 AM	JPG File	250 KB
KP Flora Mora2	4/8/2020 9:26 AM	Adobe Acrobat D...	259 KB

This box when checked will open and show all the extracted files.

Notice all the different file formats, if you import all the formats onto your tablet it will take up space, so decide on which format you prefer, select that format "QLI or CQP" the formats I prefer.

Plug-Ins Batch Import continued. . .

Name	Date modified	Type	Size
KP Flora Mora.ans	4/8/2020 9:26 AM	ANS File	27 KB
KP Flora Mora.cqp	4/8/2020 9:26 AM	CQP File	56 KB
KP Flora Mora.dxf	4/8/2020 9:26 AM	DXF File	29 KB
KP Flora Mora.hqf	4/8/2020 9:26 AM	HQF File	92 KB
KP Flora Mora.iqp	4/8/2020 9:26 AM	IQP File	28 KB
KP Flora Mora	4/8/2020 9:26 AM	JPG File	236 KB
KP Flora Mora.pat	4/8/2020 9:26 AM	PAT File	5 KB
KP Flora Mora	4/8/2020 9:26 AM	Adobe Acrobat D...	246 KB
KP Flora Mora.plt	4/8/2020 9:26 AM	PLT File	50 KB
<input checked="" type="checkbox"/> KP Flora Mora.qli	6/23/2015 6:14 PM	QLI File	4 KB
KP Flora Mora.ssd	4/8/2020 9:26 AM	SSD File	52 KB
KP Flora Mora	4/8/2020 9:26 AM	Text Document	48 KB
KP Flora Mora	4/8/2020 9:26 AM	HQF File	92 KB
KP Flora Mora	4/8/2020 9:26 AM	IQP File	28 KB
KP Flora Mora	4/8/2020 9:26 AM	JPG File	236 KB
KP Flora Mora	4/8/2020 9:26 AM	PAT File	5 KB
KP Flora Mora	4/8/2020 9:26 AM	Adobe Acrobat D...	246 KB
KP Flora Mora	4/8/2020 9:26 AM	PLT File	50 KB
<input checked="" type="checkbox"/> KP Flora Mora.qli	6/23/2015 6:14 PM	QLI File	4 KB
KP Flora Mora.ssd	4/8/2020 9:26 AM	SSD File	52 KB
KP Flora Mora	4/8/2020 9:26 AM	Text Document	48 KB

Notice all the different file formats, if you import all the formats onto your tablet it will take up space, so decide on which format you prefer, select that format. **“QLI or CQP”** are the file formats I prefer.

By clicking on that design format you are selecting it notice the Checkmark to the right

Plug-Ins Batch Import continued. . .

1. Now that you have selected the file format, right click on design file format. “Right Click”

<input type="checkbox"/>	KP Flora Mora.iqr	4/8/2020 9:26 AM	IQR File	92 KB
<input type="checkbox"/>	KP Flora Mora.iqp	4/8/2020 9:26 AM	IQP File	28 KB
<input checked="" type="checkbox"/>	KP Flora Mora	4/8/2020 9:26 AM	JPG File	236 KB
<input type="checkbox"/>	KP Flora Mora.pat	4/8/2020 9:26 AM	PAT File	5 KB
<input type="checkbox"/>	KP Flora Mora	4/8/2020 9:26 AM	Adobe Acrobat D...	246 KB
<input type="checkbox"/>	KP Flora Mora.plt	4/8/2020 9:26 AM	PLT File	50 KB
<input checked="" type="checkbox"/>	KP Flora Mora.qli	6/23/2015 6:14 PM	QLI File	4 KB
<input type="checkbox"/>	KP Flora Mora.ssd	4/8/2020 9:26 AM	SSD File	52 KB
<input type="checkbox"/>	KP Flora Mora	4/8/2020 9:26 AM	Text Document	48 KB

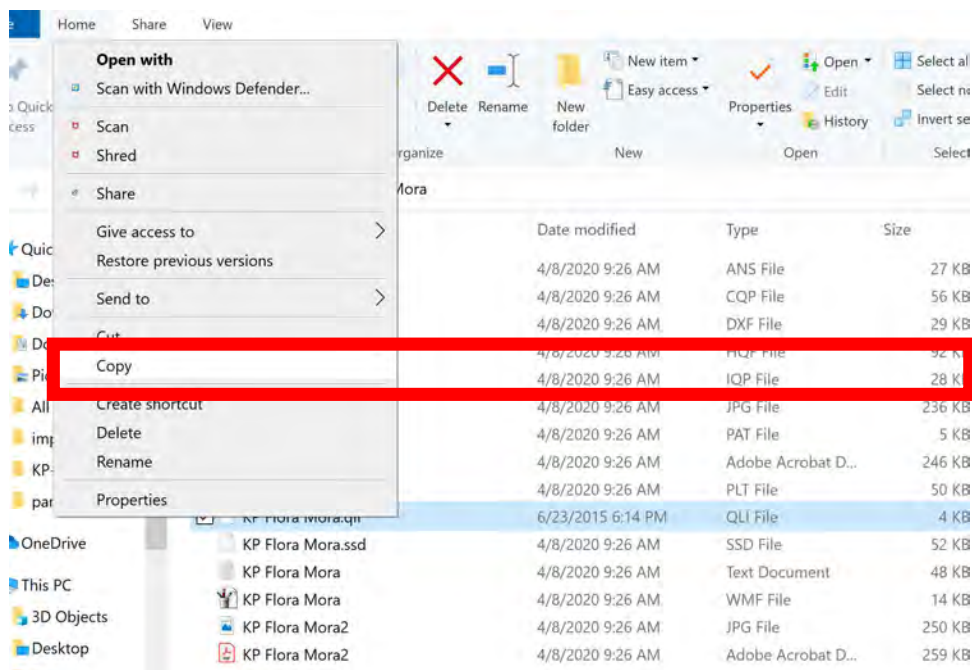

After you have “Right Clicked” click on **COPY**. We want to copy not remove incase something happens to your tablet you have a back up.

Plug-Ins Batch Import continued. . .

Windows-SSD (C:)	import design batch	4/7/2020 1:29 PM	File folder
USB Drive (D:)	ice dreams tri 2 p2p ALL QUILT FORM...	2/5/2020 10:06 AM	File folder
Main Info (N:)	ds tall feather tri p2p qnf	2/5/2020 10:06 AM	File folder
Workspace (T:)	<input checked="" type="checkbox"/> april 4 2020 kite quilt design	4/8/2020 12:35 PM	File folder

Click on folder to
open.

Plug-Ins Batch Import continued. . .

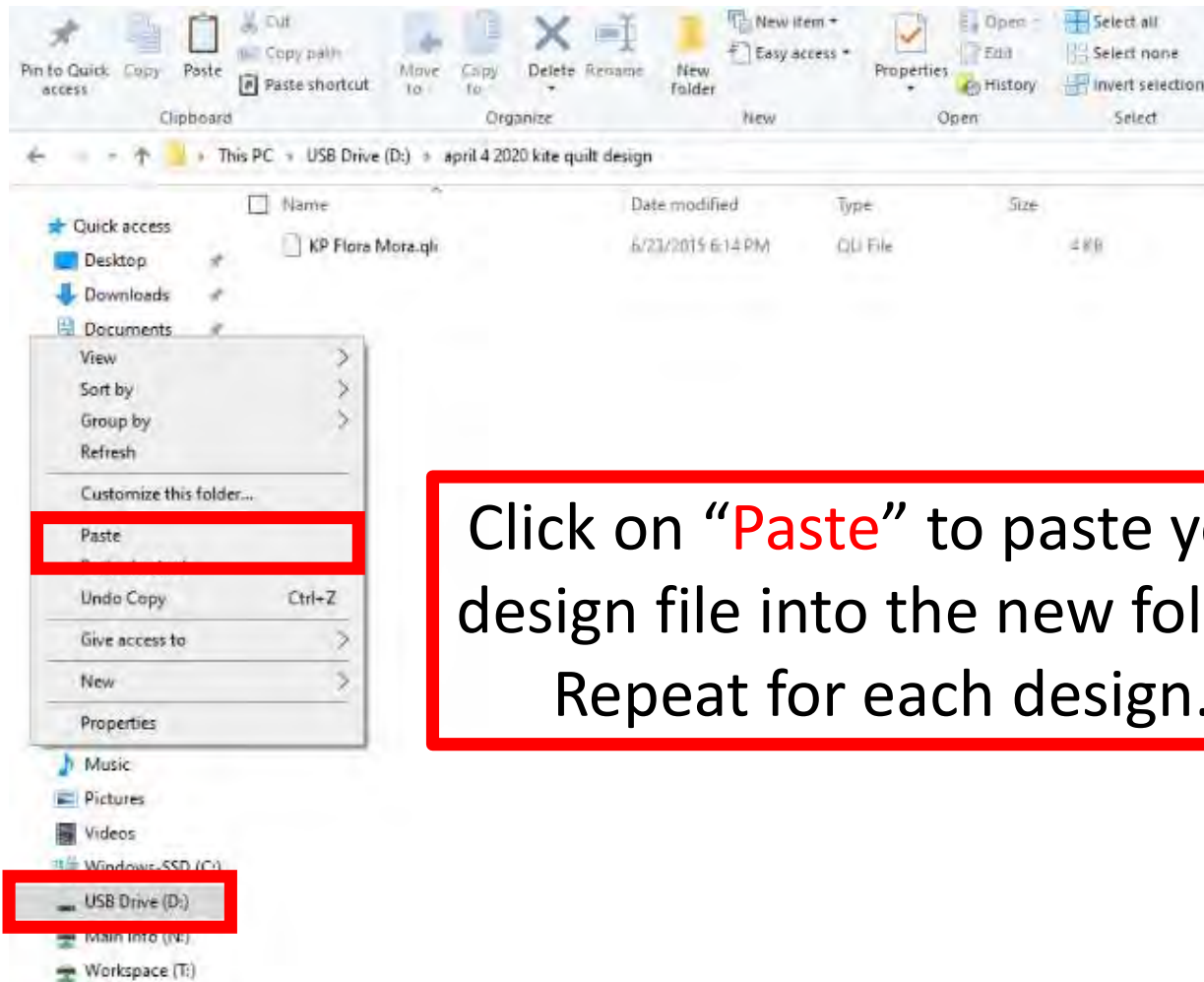

Click on folder to open.

Click on “**Paste**” to paste your design file into the new folder.
Repeat for each design.

Plug-Ins Batch Import continued...

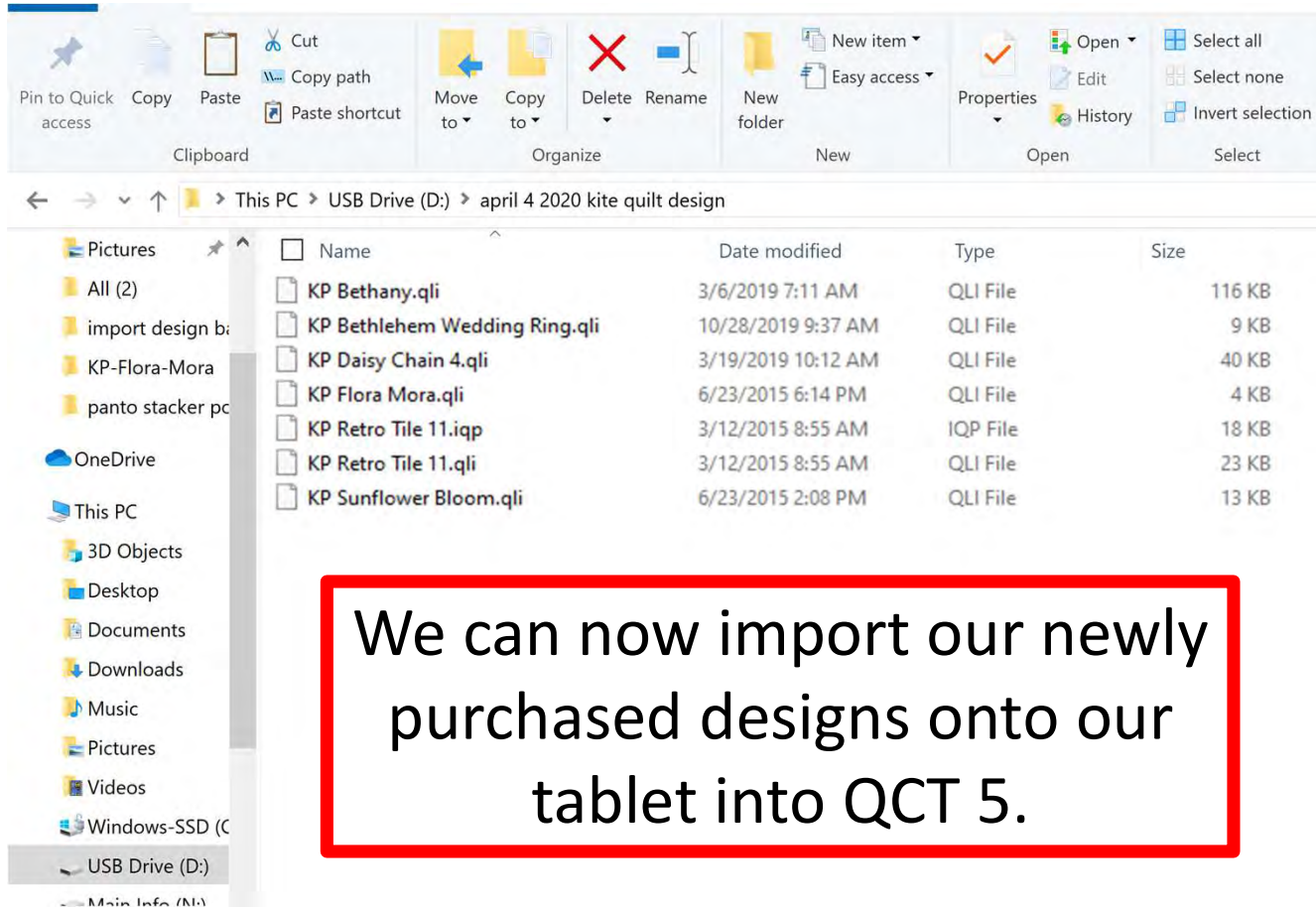

Plug-Ins Batch Import continued. . .



USB Flash Drive



With your designs downloaded onto your USB flash drive, take the flash drive and put it into your tablet USB port.



Newer tablets may require an USB-C to USB Adapter. If your tablet does not have a USB port, if your tablet does not it will require this adapter.

Plug-Ins Batch Import continued. . .



USB Flash Drive

Turn on your tablet in
open your QCT 5 in
“Simulation Mode.”

You can open and import from several
different places with QCT 5.

“Select & Sew”
“Pantograph”
“PatternCAD”
“QuiltCAD”

We will choose “Select & Sew.”

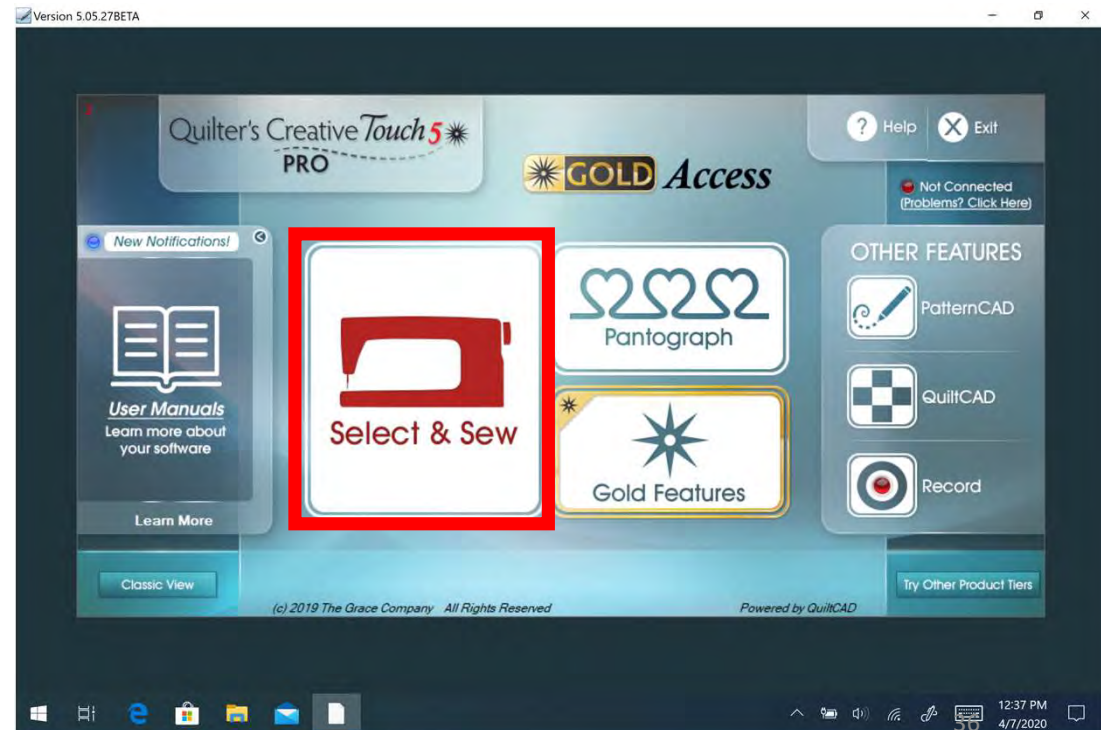

Plug Ins Batch Import continued. . .

“Select & Sew”
placement screen,
click on “Plug-Ins”

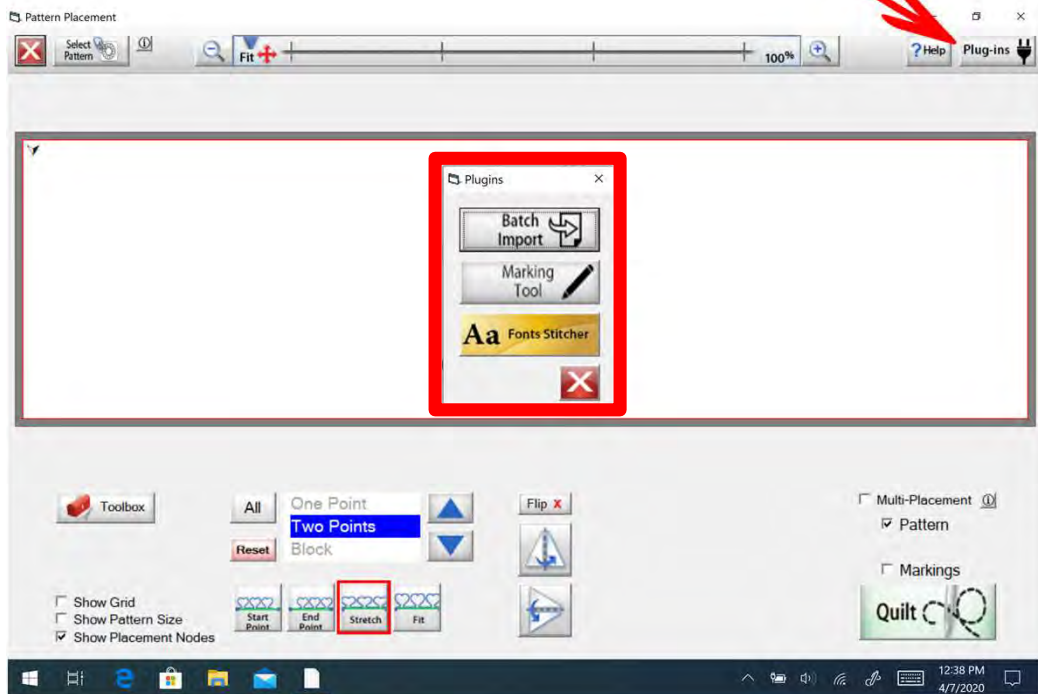

Click on “Batch Import.”

Plug-Ins Batch Import continued. . .

“Batch Import”
screen will open
select “New Drive”
we are looking to find
our USB Flash Drive.

Multi All/None Copy Paste Cut Delete

File Types CMD CQP CSV DXF HQF QDATA QLI SSD TAP TXT XY

Plug-Ins Batch Import continued...

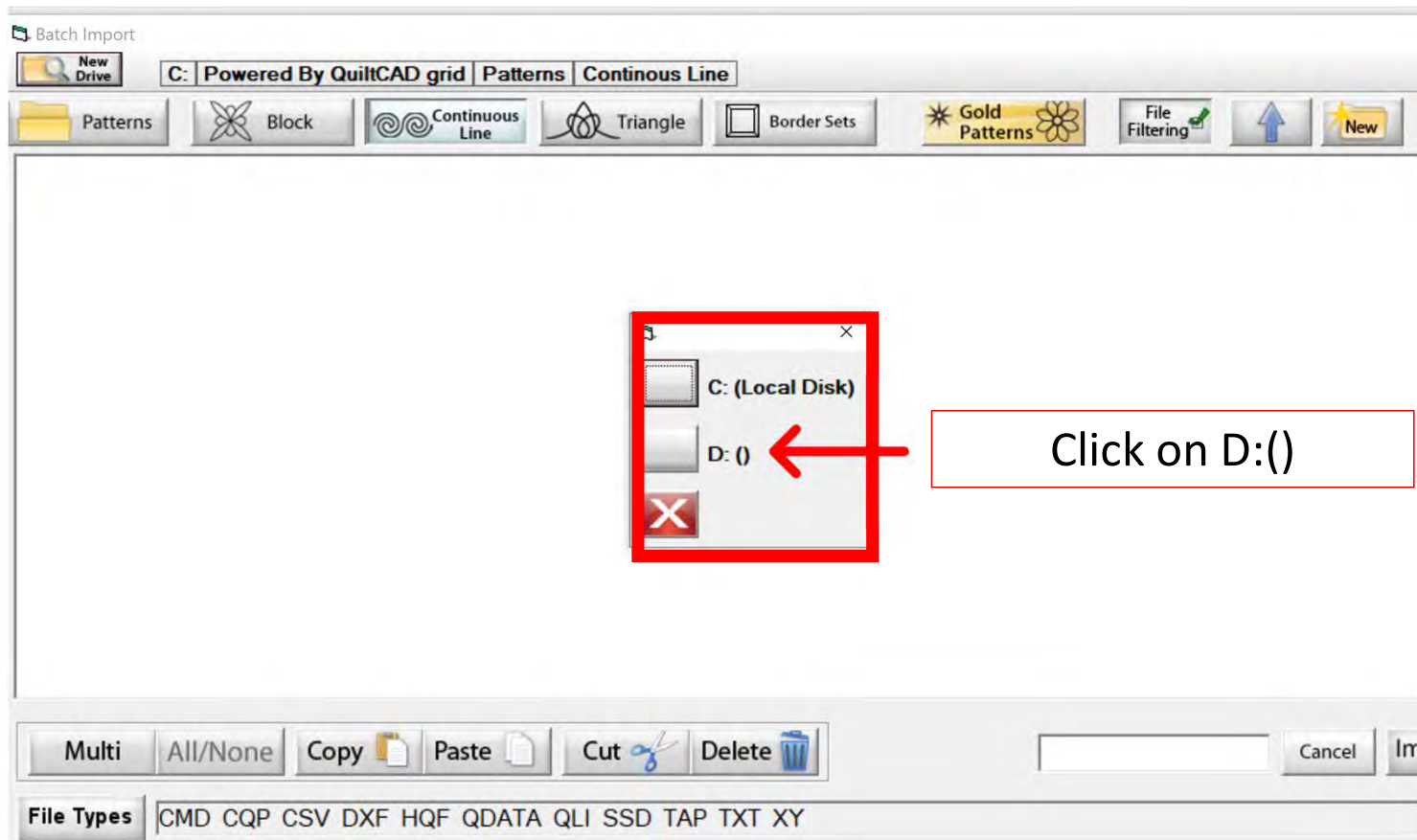

Plug-Ins Batch Import continued...

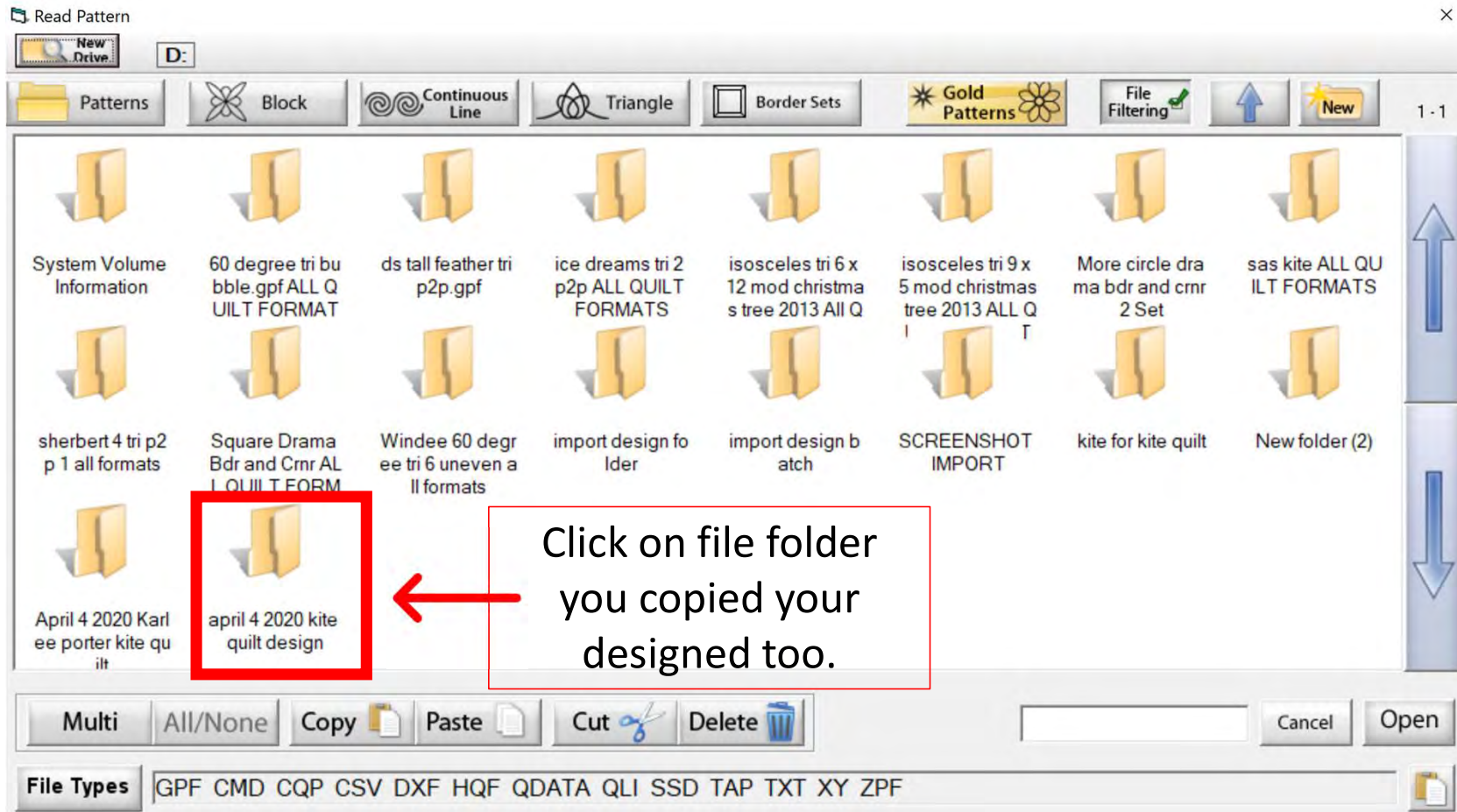

Plug-Ins Batch Import continued...

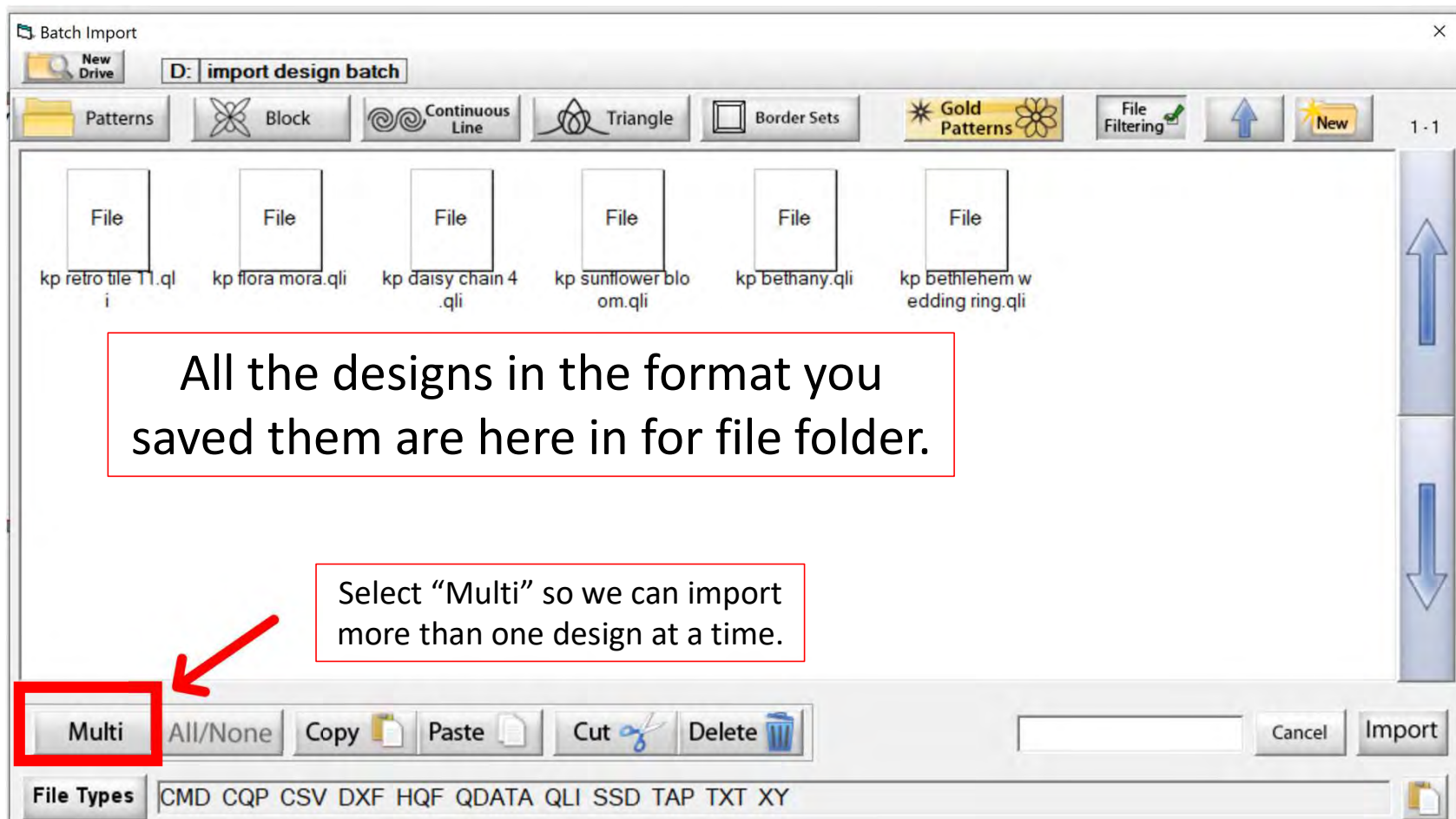

Plug-Ins Batch Import continued...

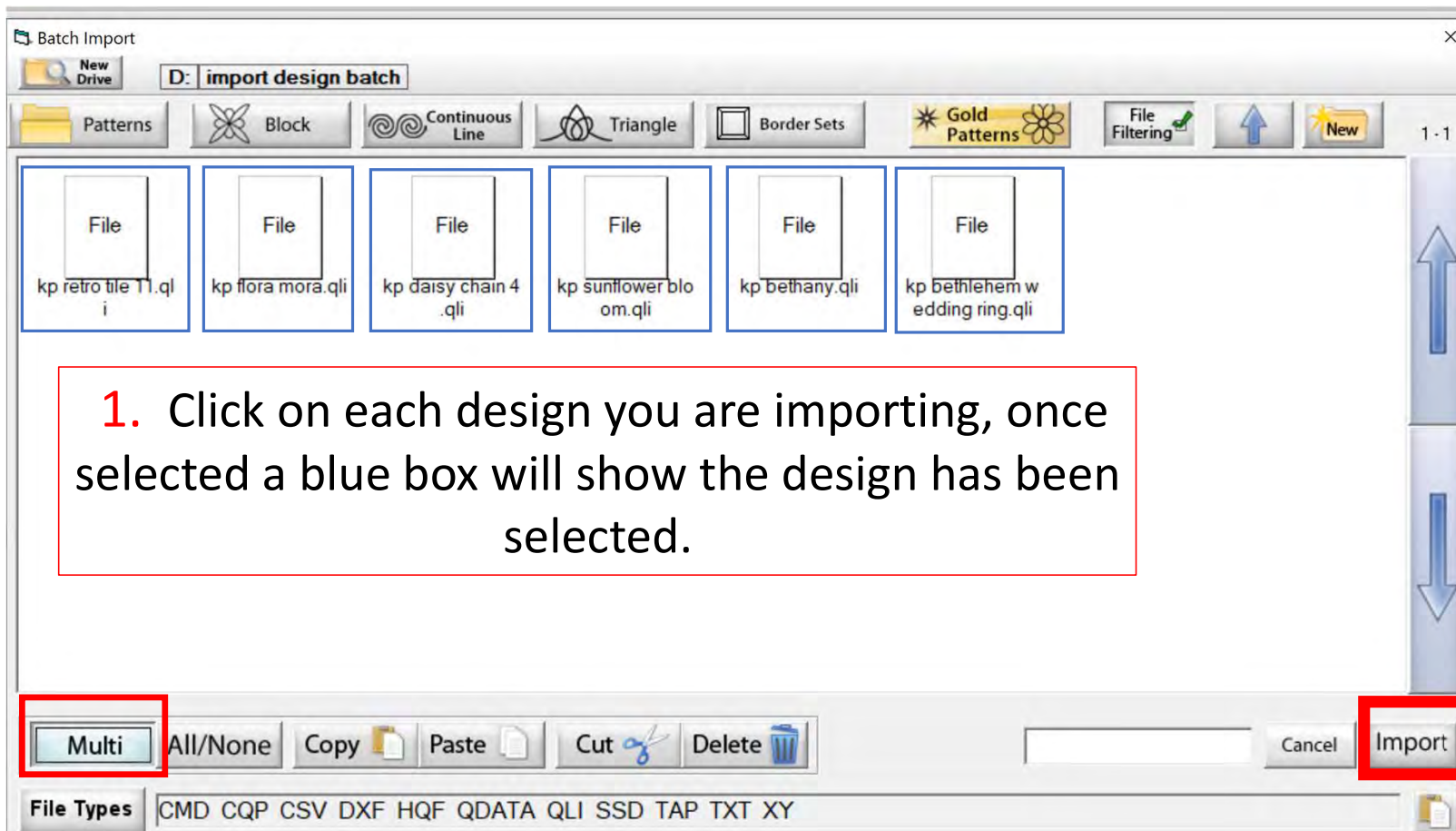

1. Click on each design you are importing, once selected a blue box will show the design has been selected.

2. Click on "Import" to import your designs.

Plug-Ins Batch Import continued. . .

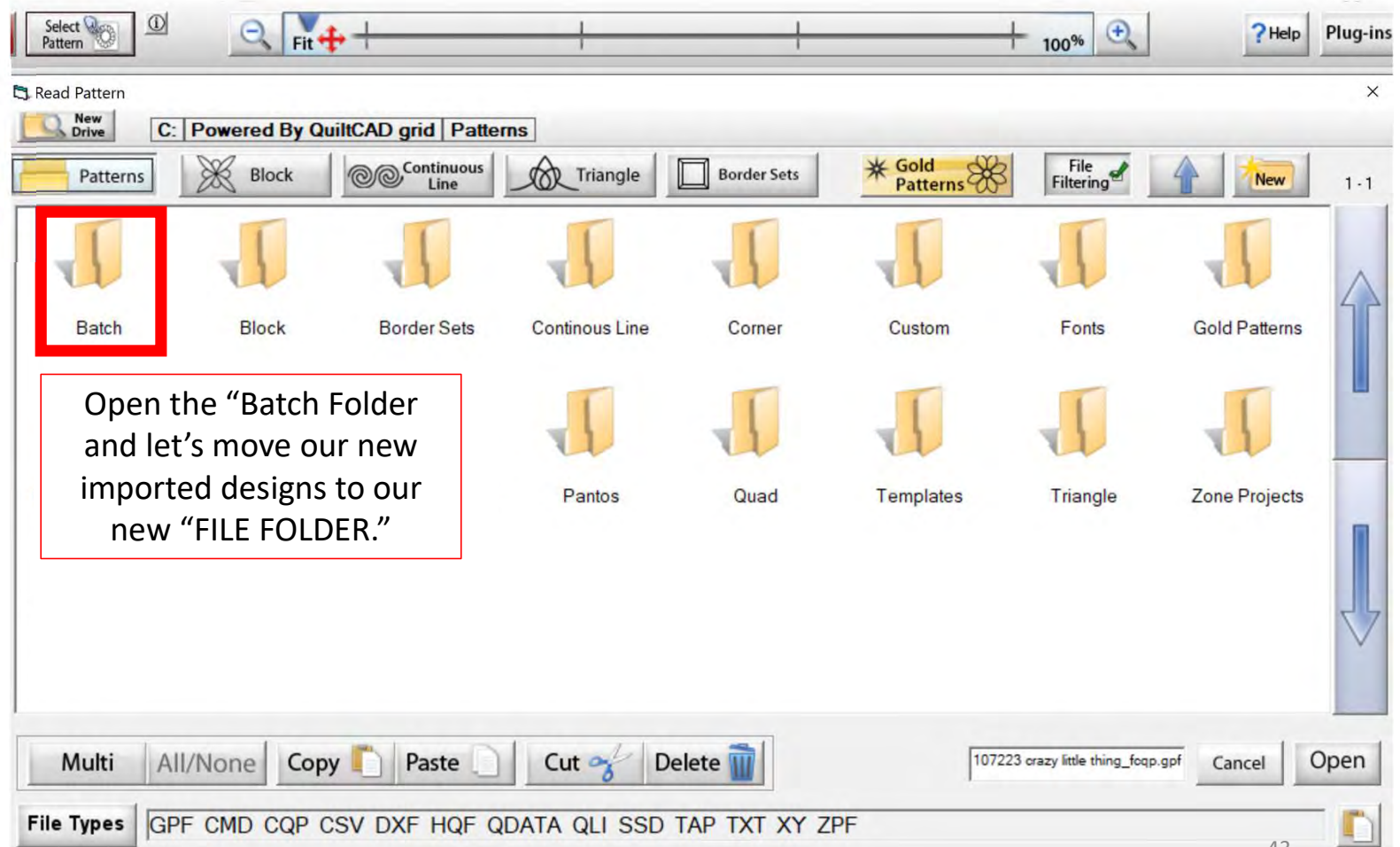

Plug-Ins Batch Import continued. . .

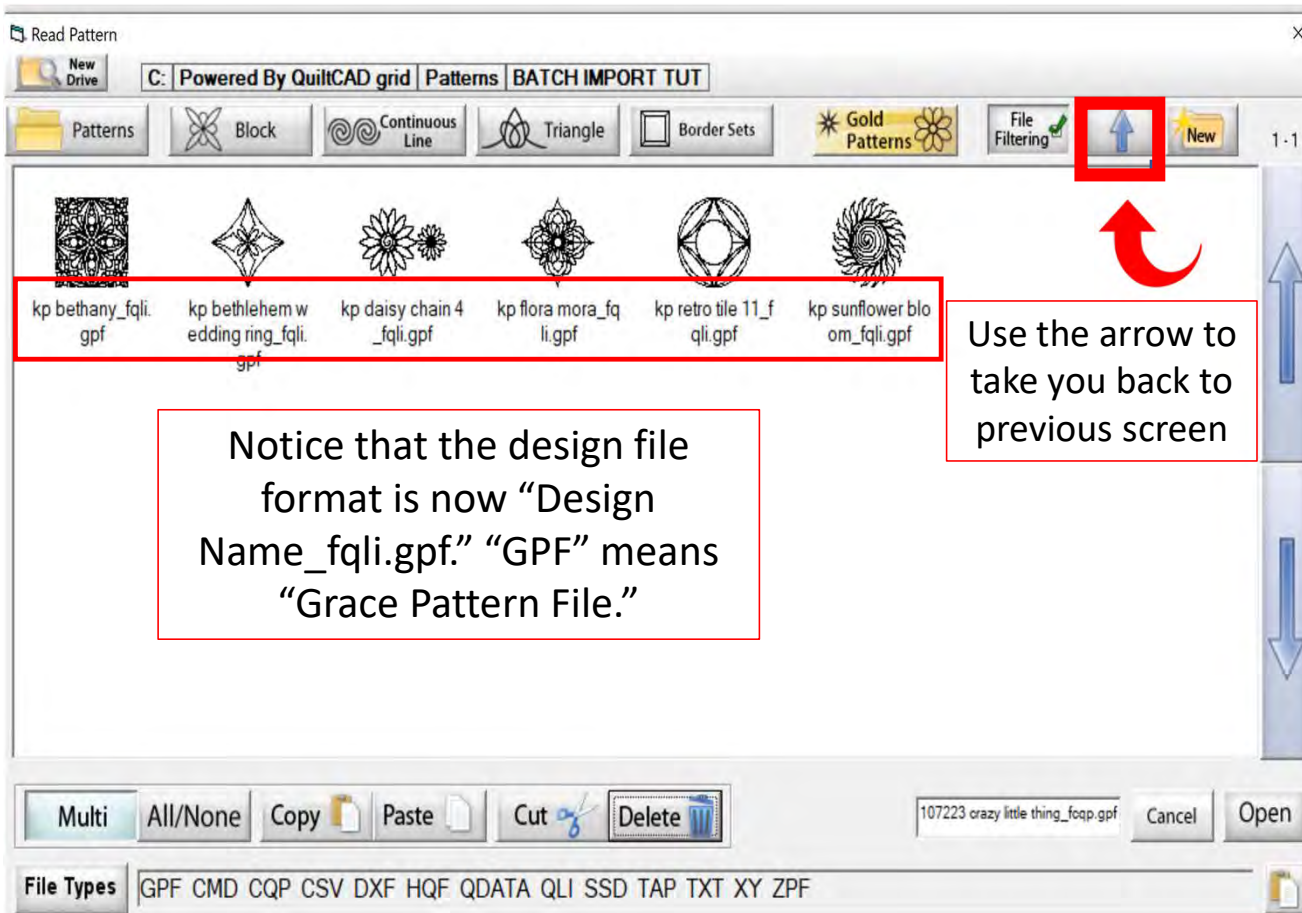

Your open **"Batch"** folder will show you your newly imported design(s). Let's move our design(s) to our new filing folder.

First "Create a new "Filing Folder" to move your design(s) too. Click on the "Back Arrow" top right corner. Now you are back where your filer folders are, and we can now create a new folder.

Plug-Ins Batch Import continued...

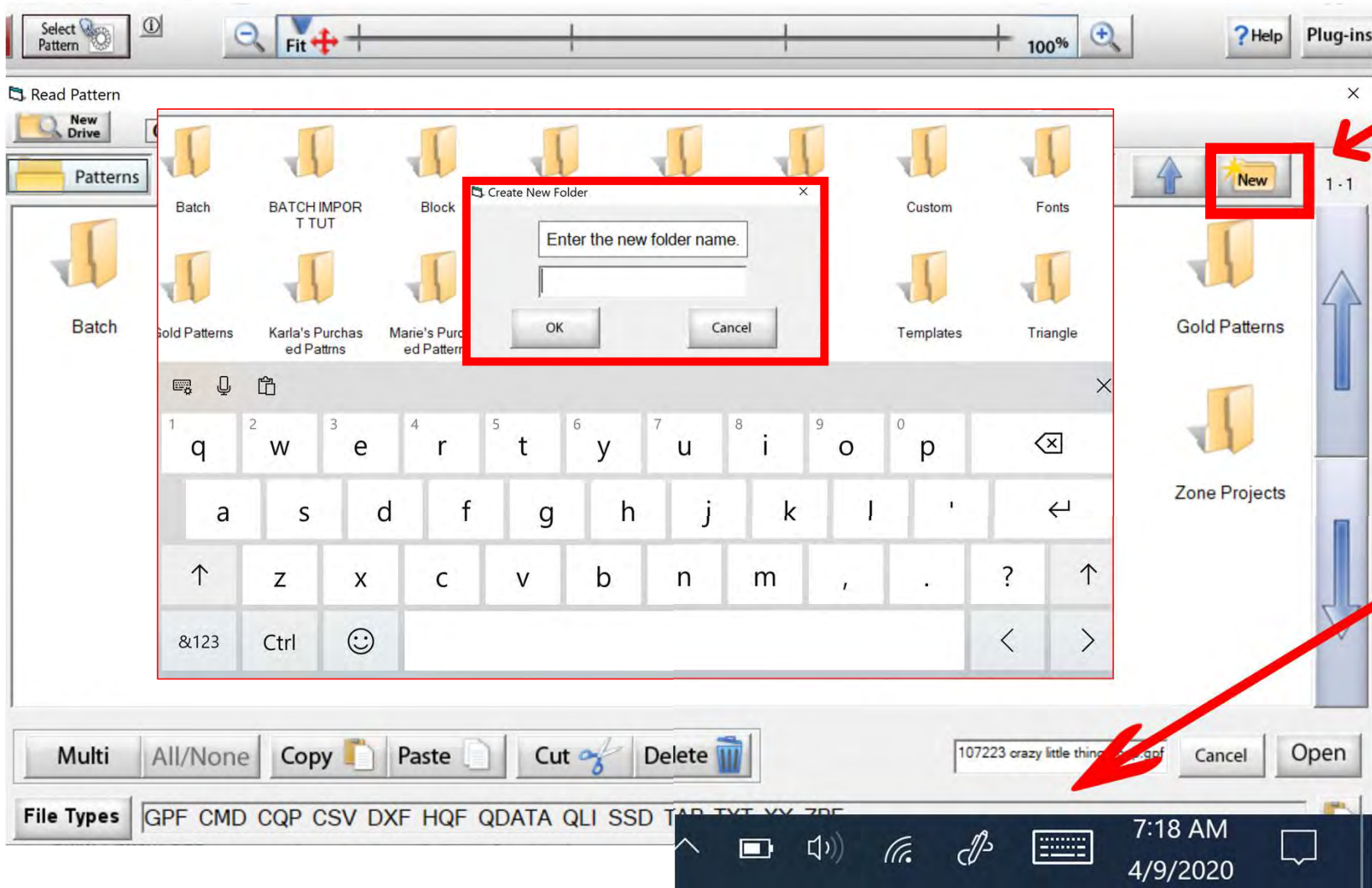

Click on “New” with the file folder icon will popup. To enter the folder name, find your keyboard, lower left of tablet screen. Click on it and your keyboard will appear to type the file folder name.

Plug-Ins Batch Import continued...

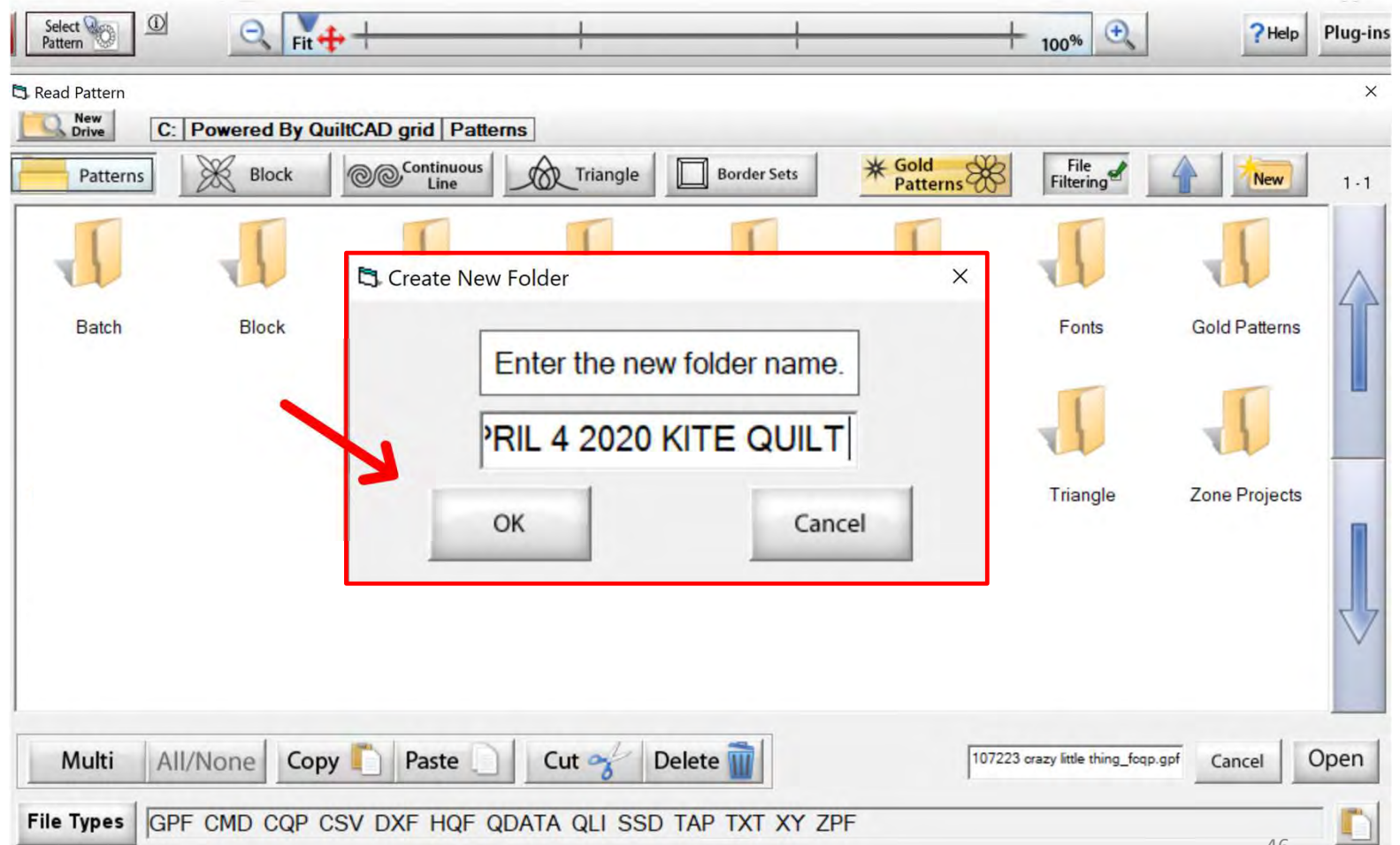

Plug-Ins Batch Import continued. . .

Your new file folder is now ready for you to put your new purchased design(s) into. Click on the back arrow, (top right) to find your batch folder and design(s). We will cut them out of our “Batch Folder” and paste them into our new file folder.

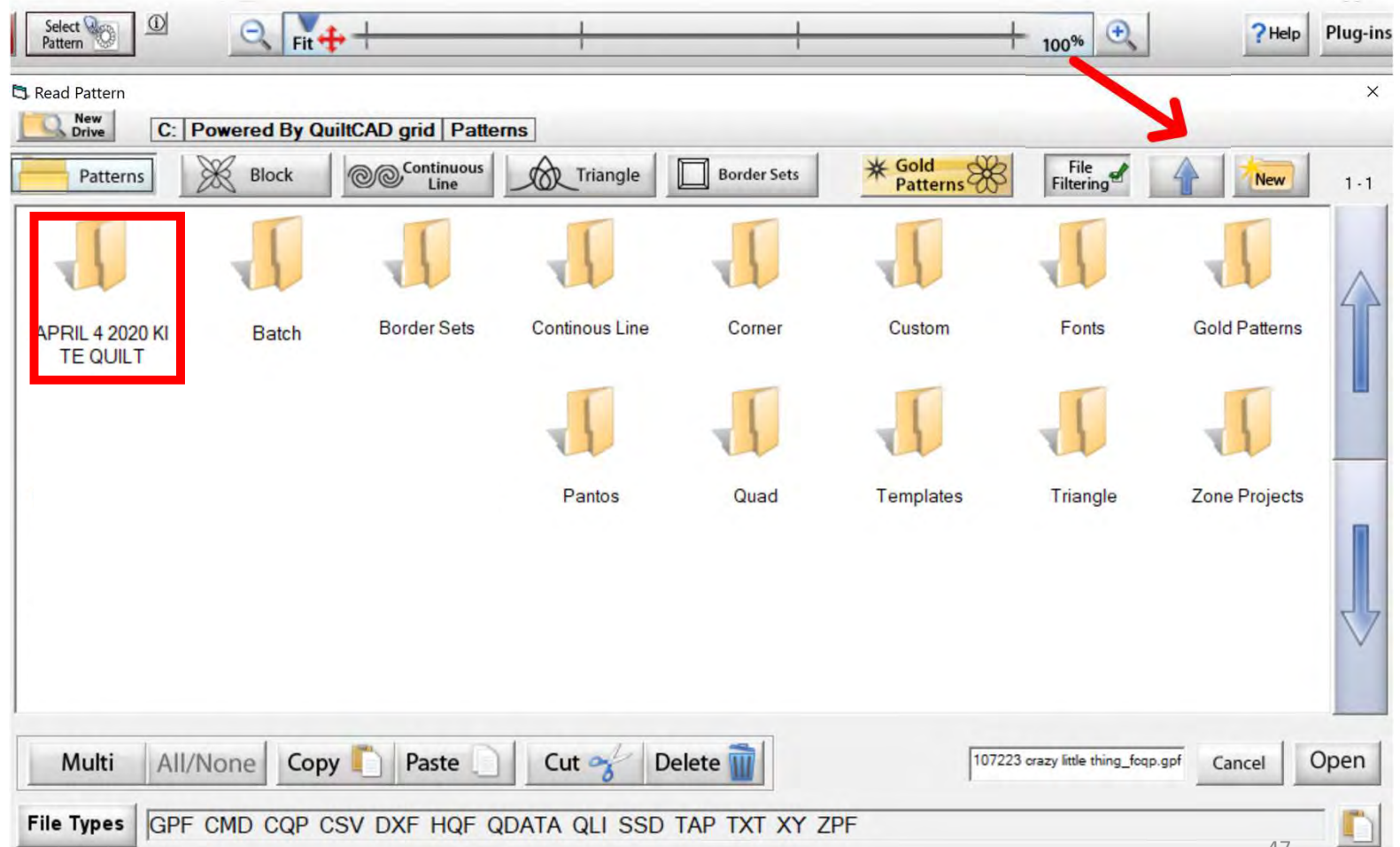

Plug-Ins Batch Import continued. . .

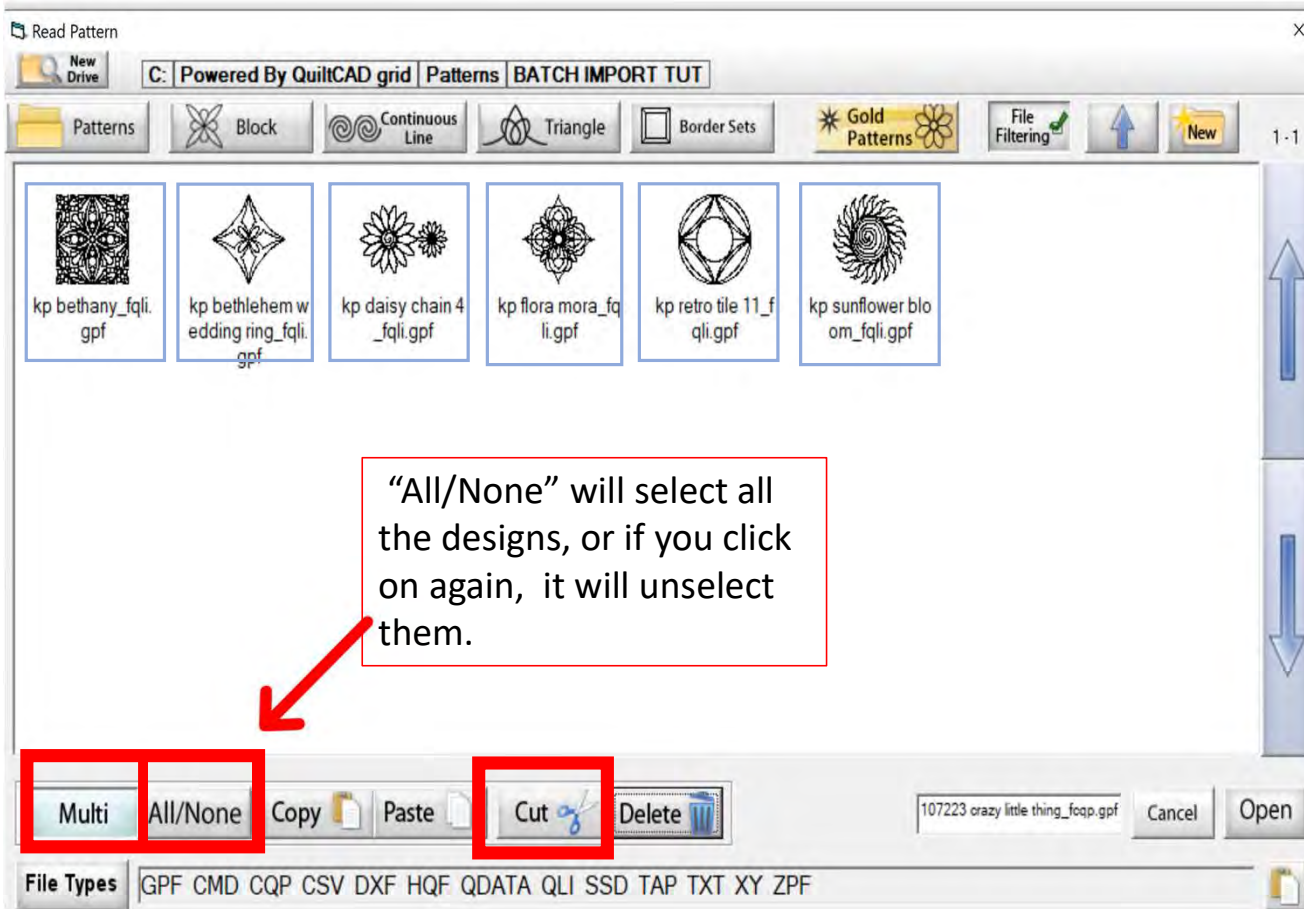

“All/None” will select all the designs, or if you click on again, it will unselect them.

Click on “Multi” and “All/None” this allows you to select all the designs so we can cut and paste them all at the same time.

After selecting the design(s) you want in your new folder click on “Cut.” You will see the design(s) disappear off the screen. Click on your back arrow, remember top right.

Plug-Ins Batch Import continued. . .

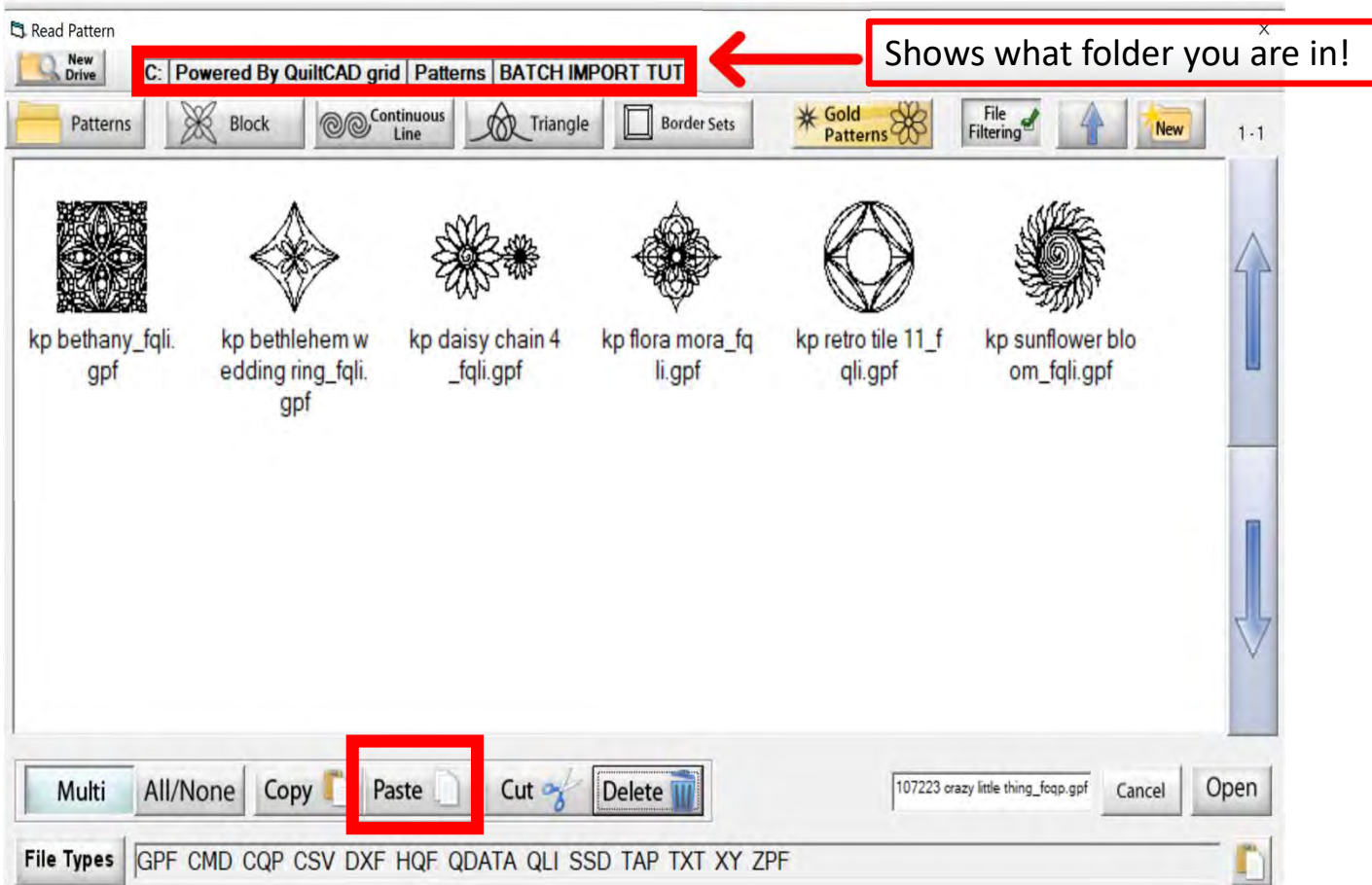

When you are in your “New File Folder,” click on “Paste.” This will paste your design(s) into your new folder.

Now you are ready to start quilting that quilt top you purchased the design(s) for.

Plug-Ins Batch Import continued. . .

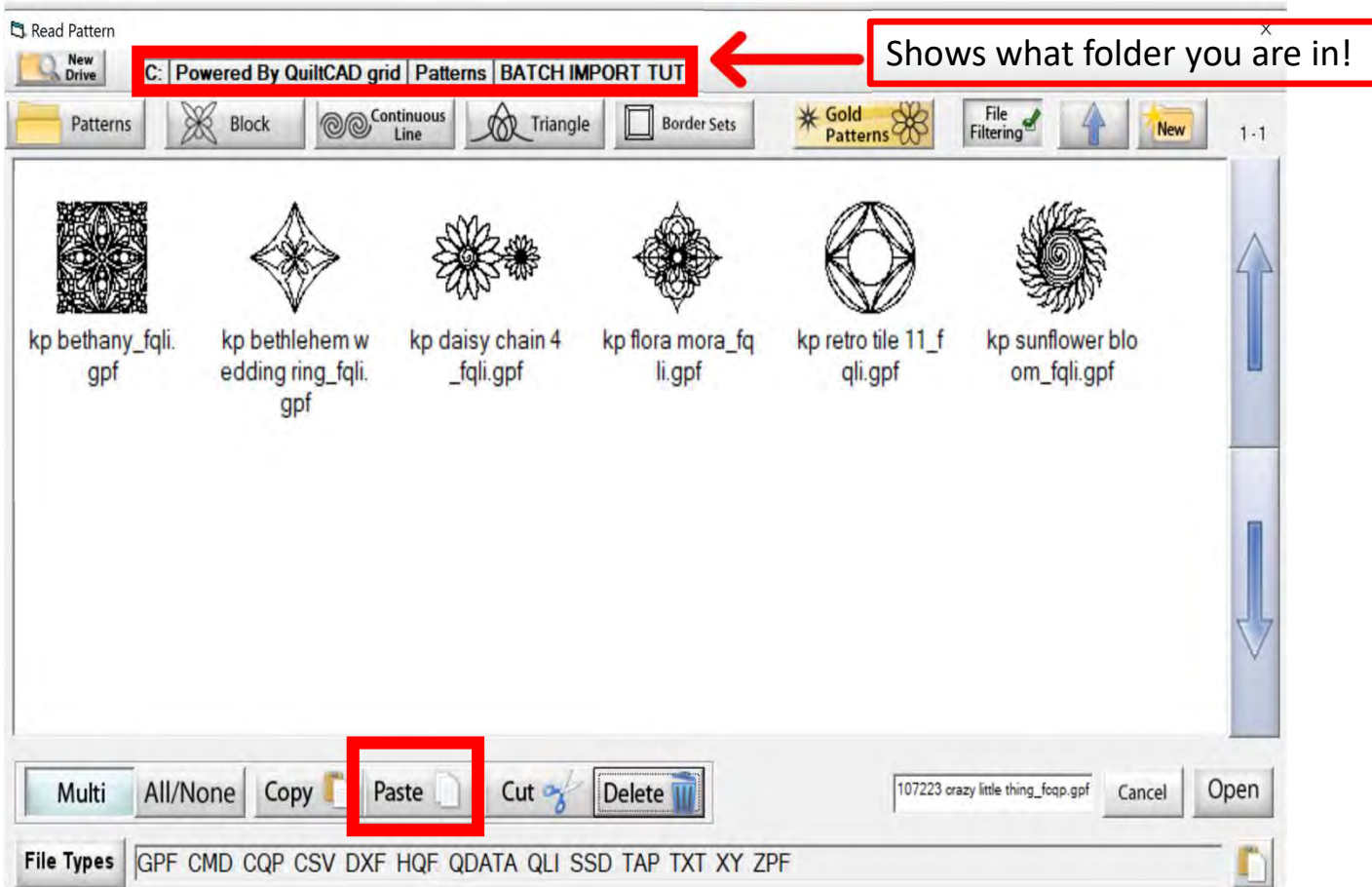

Shows what folder you are in!

If you have a GPF (Grace Pattern File) file, you won't be able to import them. Just Copy them from your thumb drive or where you purchased them and paste them into the folder.

TOOLBOX

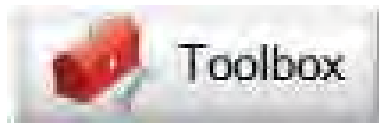

PLACEMENT METHODS

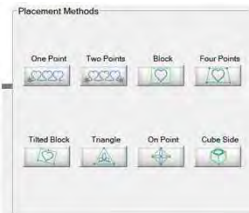

METHODS USED TO PLACE A PATTERN/DESIGN ON A PIECED BLOCK OR QUILT

RULER

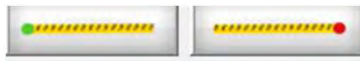

MEASURES DISTANCES ON YOUR QUILT, OR THE SIZE OF A BLOCK OR PANTOGRAPH

MARKING TOOL



ADD MARKINGS AROUND YOUR PATTERN/DESIGN TO PLACE WITH ACCURACY

SET SAFE AREA

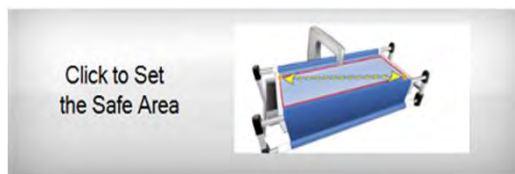

RESET YOUR QUILTING AREA, WHICH IS DETERMINED BY THE LENGTH (THROAT) OF YOU MACHINE AND YOUR QUILT TOP WIDTH

Marking tool

You can find this awesome feature a couple of places on your screen.

1. The Plug-ins button/icon is at the top right corner of your screen.
2. Inside our Toolbox you will also find the marking tool by scrolling through.

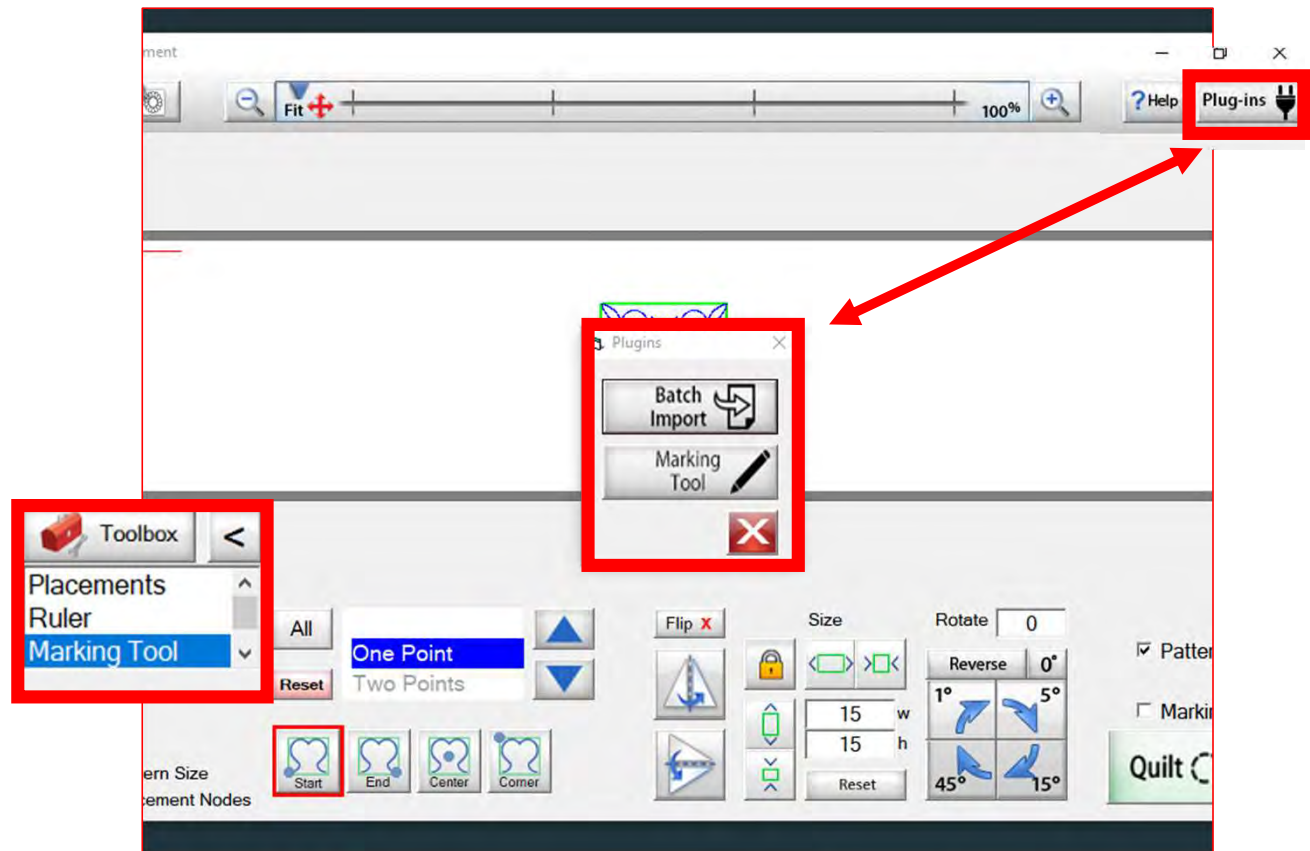

Explore how the marking tool will help you place your design precisely inside your block using the marking tool.

Marking tool continued. . .

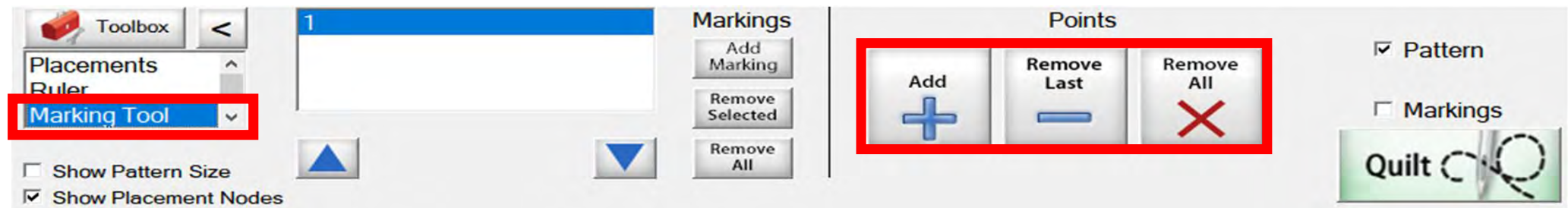

Quilt block with design placement outside of block.

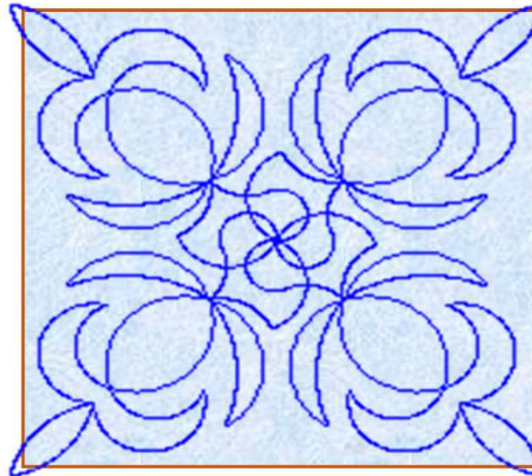

Quilt block with new placement of design inside the block.

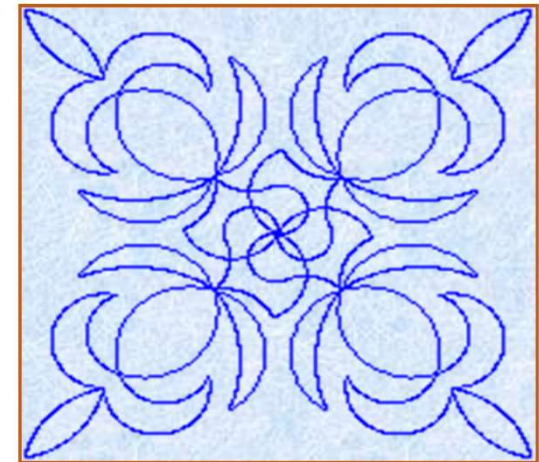

Marking tool helps you draw around your block so you can see on your tablet screen how well you placed your design on your block.

Marking tool continued...

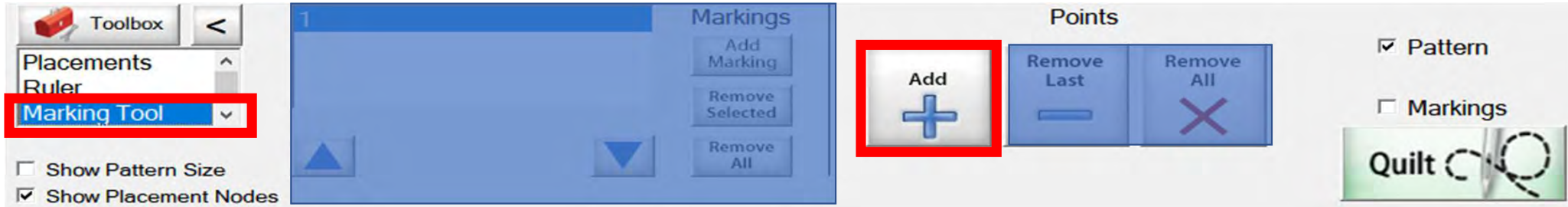

Quilt Block

Move machine to first marking point and Click "Add +" button

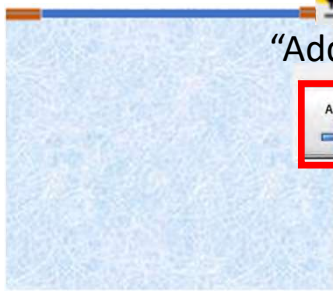

"Add +"

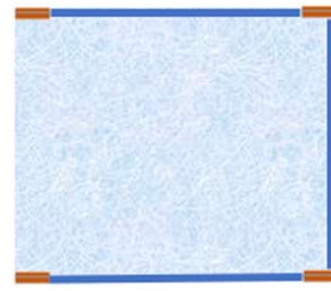

"Add +"

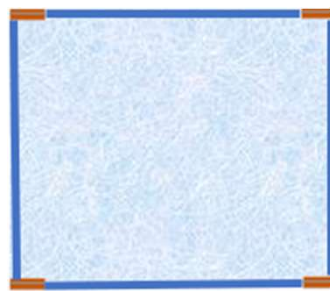

Move machine to next marking point click on "Add +" button

Marking tool continued...

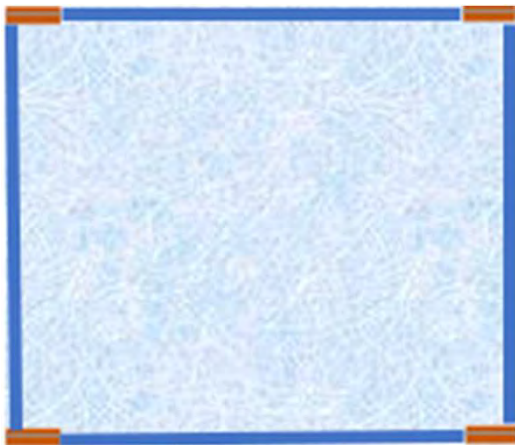

“Remove Last”
removes
previous mark

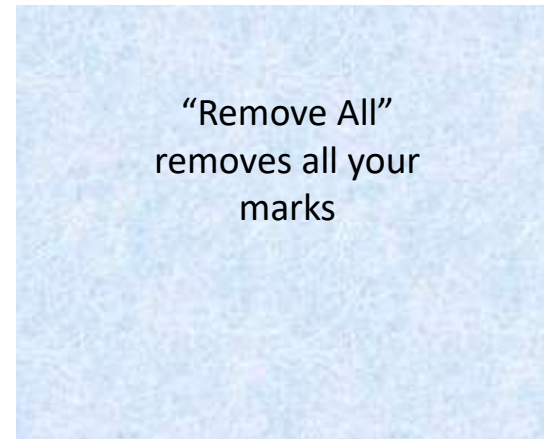

“Remove All”
removes all your
marks

Marking tool continued. . .

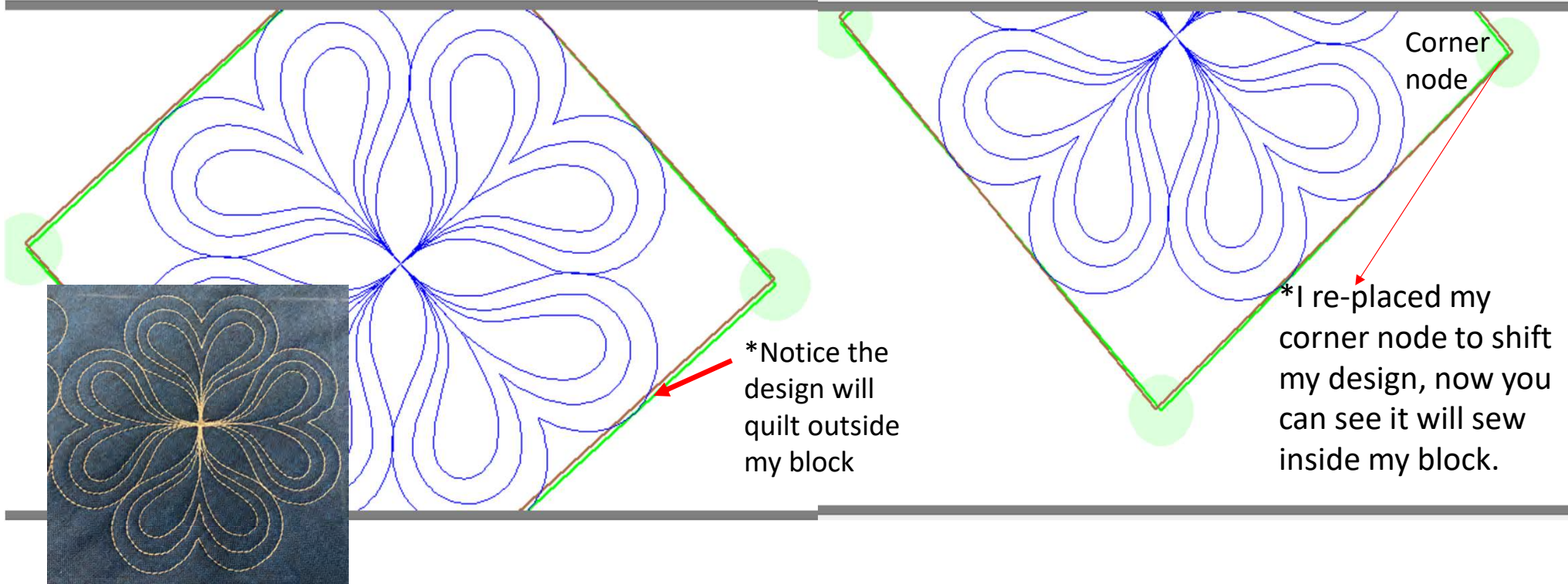

Screen shot of “Marking Tool” to place your design inside the block so it won’t sew outside your block seams boundary.

Marking tool continued...

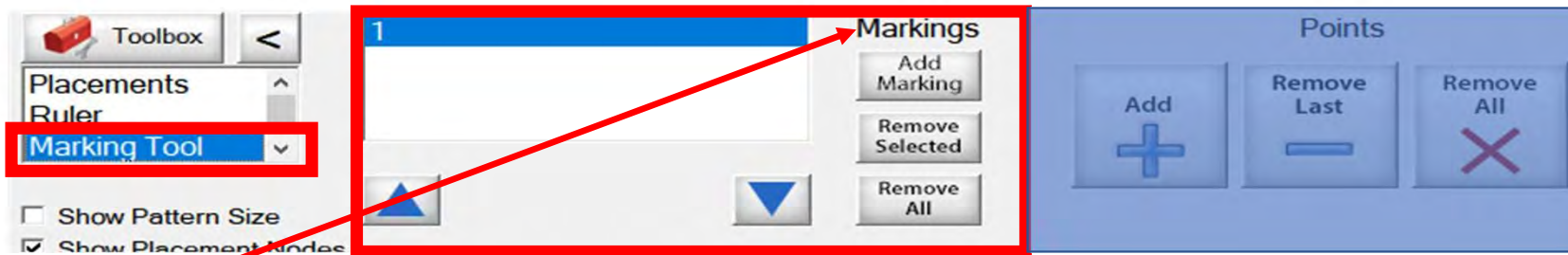

“Markings” will place “Marks” not lines around your block (—)

Quilt Block

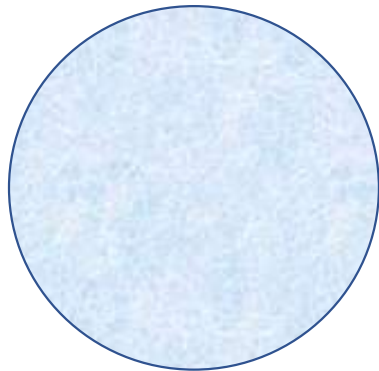

Decide how many placement marks you would like around your block for demonstration I have chosen 8

Marking tool continued. . . Add mark (—) markings around your block

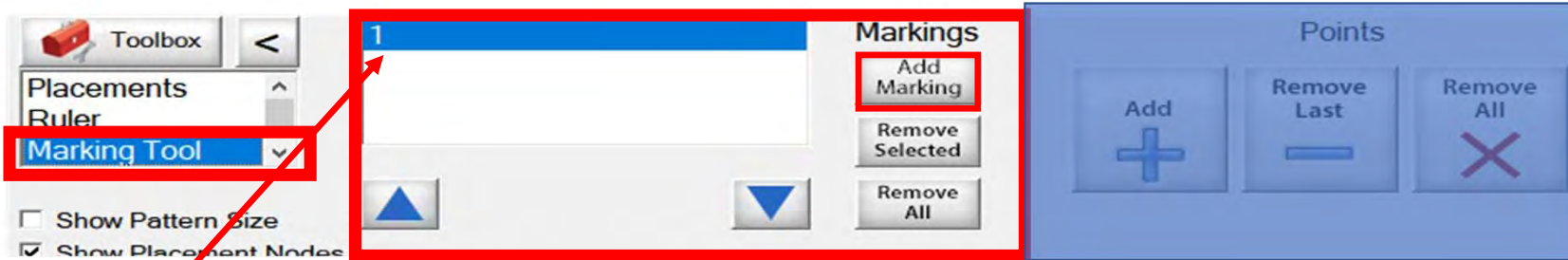

One (1) is preset

“Add Marking”
Position



Add mark 2 and so on click on “Add Marking” button the “Touch Keypad” will appear, type the number 2 and select enter.

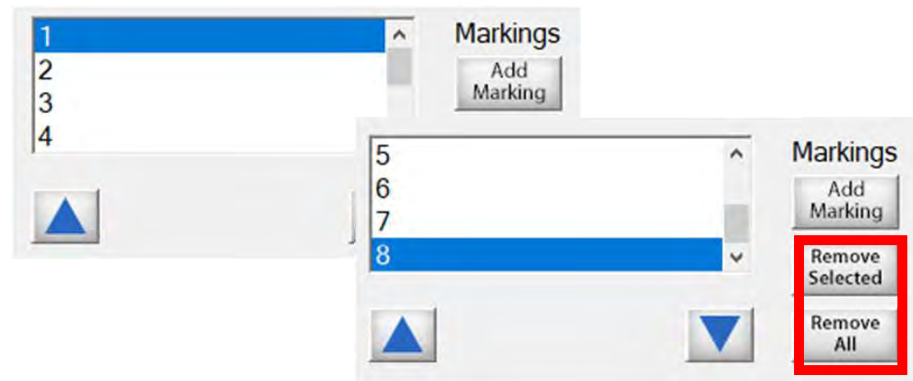

“Remove Selected”
or
“Remove All”

Continue until you have all your placement marking positions added. (remember I chose 8 positions.)

Marking tool continued. . . Add mark (—) markings around your block

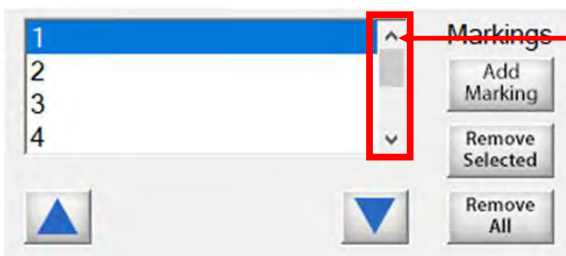
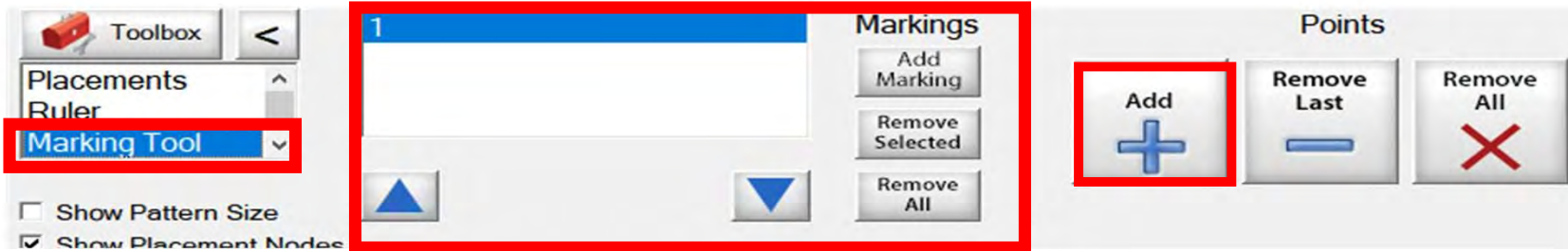

1. Use the arrows to find current position you want to mark.
2. Move your machine to that position on your block.
3. Click on "Add +" button to add marks.

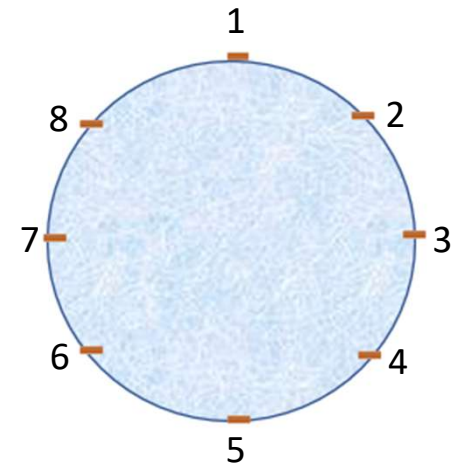

Let's place some marks around our block!

Marking tool continued. . . Add mark (—) markings around your block

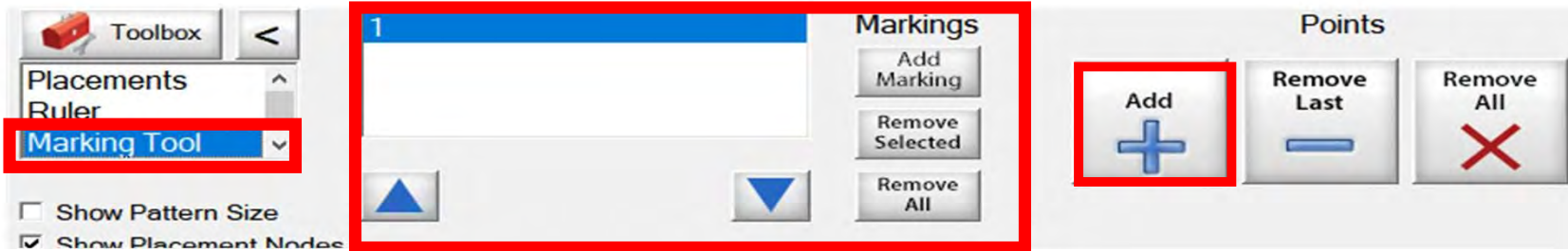

1. "Markings"
Position 1 first mark, use arrow tabs or tap on each position.

2. Move machine to position 1 on your block.
You must be on what ever position you are placing in the placement marking screen.

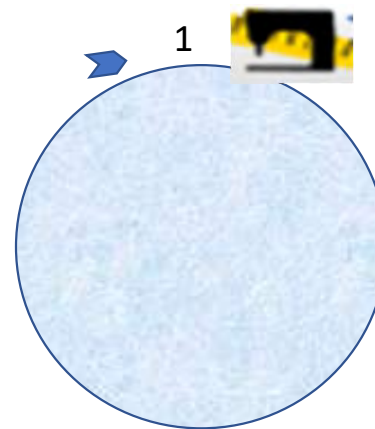

3. Click on "Add +" button to add mark.

Marking tool continued. . . Add mark (—) markings around your block

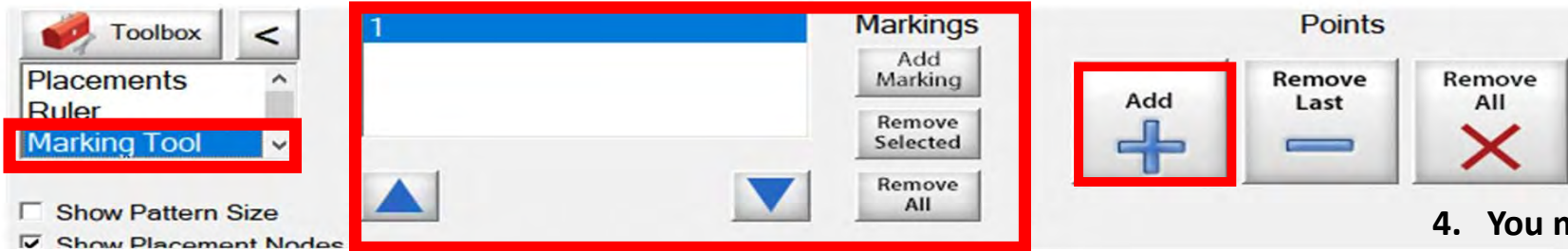

4. You must change the marking position to (3) before you can move machine and click "Add +" to place the next mark and sew fourth.

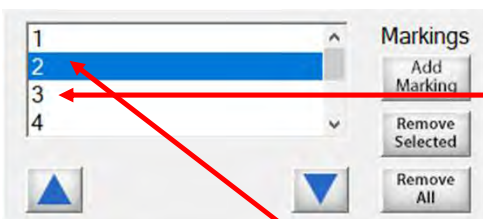

1. Tap on position (2) or scroll down using arrow to move to the new marking position on the screen.

2. Move machine to position 2 on your quilt block.

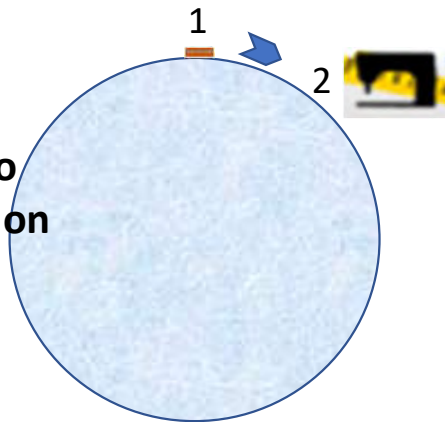

3. Click on "Add +" button to add mark.

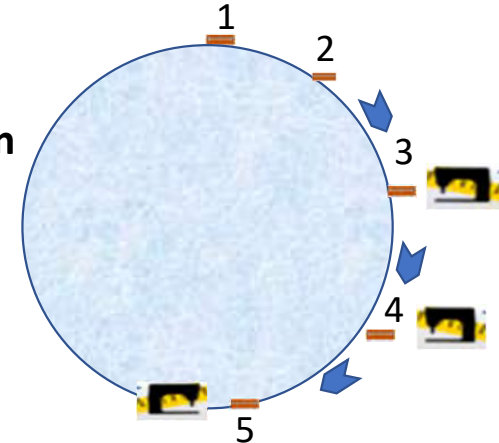

Marking tool continued. . . Add mark (—) markings around your block

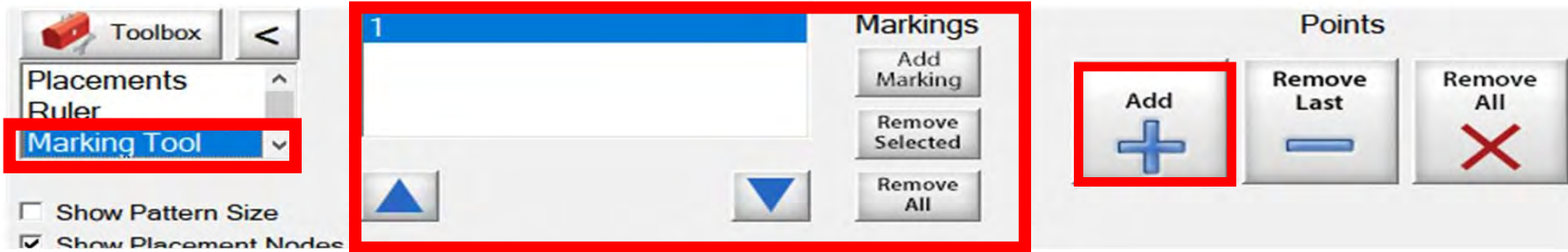

Quilting block with design placement outside the block

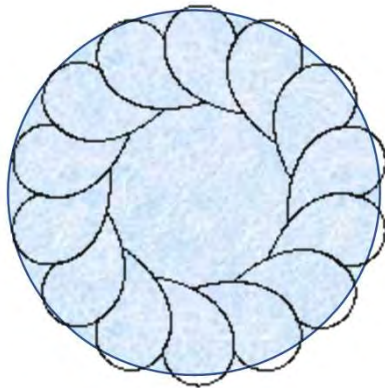

Quilt block reposition with markings design is now placed inside the block.

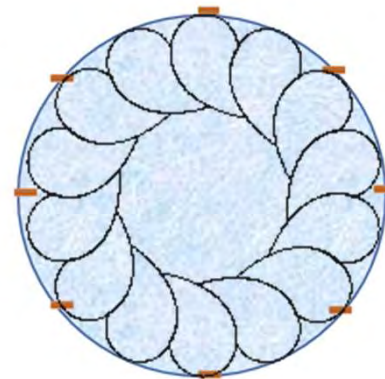

Marking tool continued. . . Add mark () markings around your block

*I moved my machine to center of my block tapped on the center node of design to place design inside my (8) marks around my block.

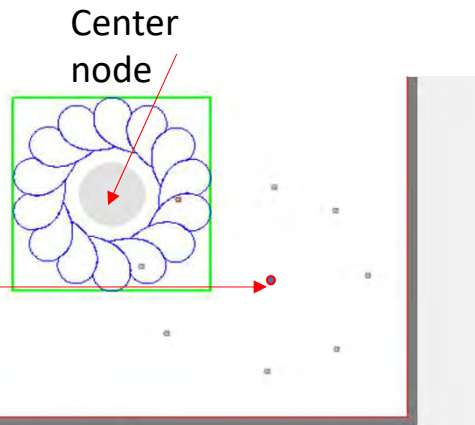

*Notice the design will quilt outside my block

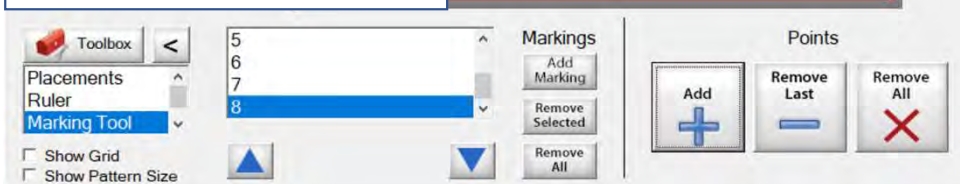
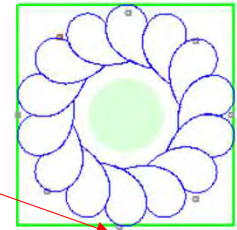

Screen shot of “Markings” to place your design inside the block, so it won’t sew outside your block seams boundary. . .

Marking tool continued. . . Add mark (—) markings around your block

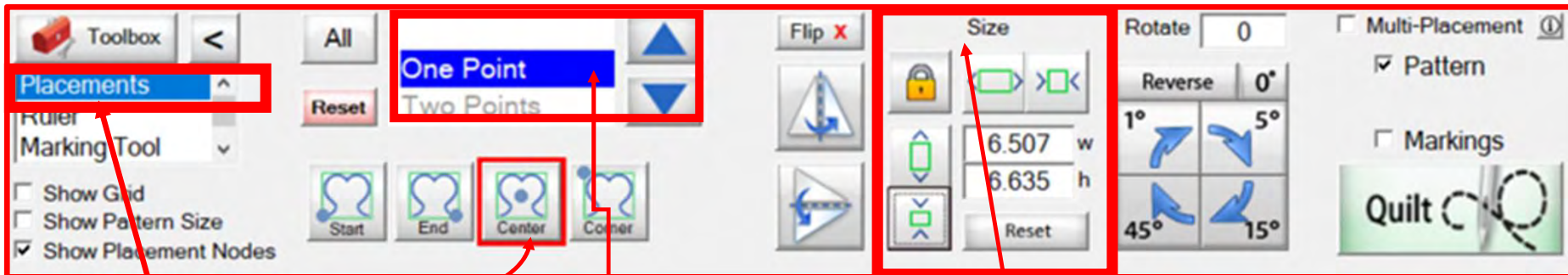

Change from
"Marking Tool" in
Toolbox to
"Placement"

Change to
"One Point"
"Center" placement

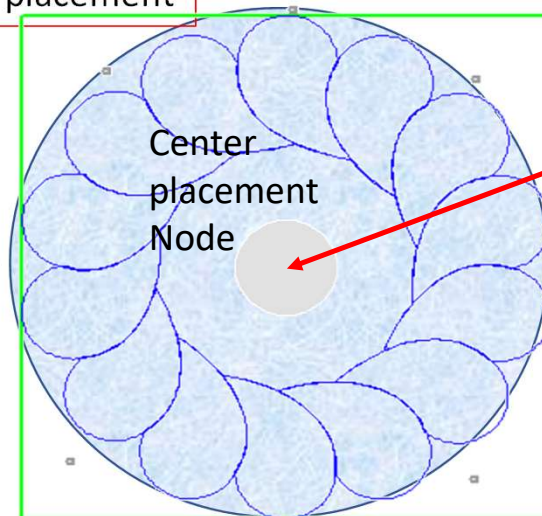

Place design in the center of your block using the placement node. Notice it is just outside the block, use the "Center Placement Node" along with the "Size". You will want to keep it locked to have it size in proportion. Size it in if to large or size it out if to small. Make the adjustments to get the right size and fit.

Marking tool continued. • • Add mark () markings around your block

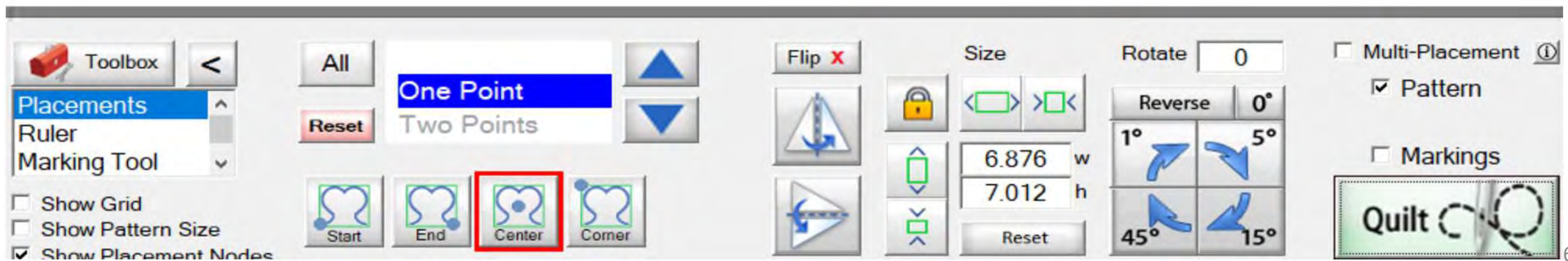
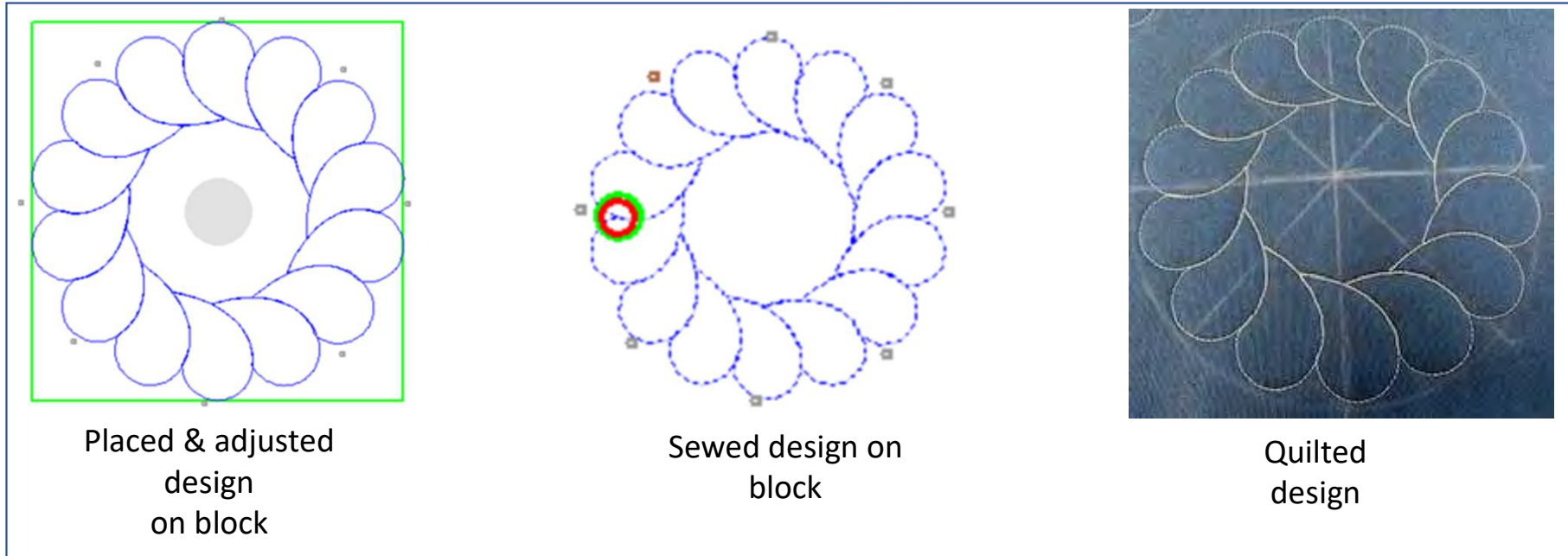

Ruler

The ruler enables you to measure blocks sizes and distances on your quilt. You can measure borders, sashing's, or block lengths, widths and find the center on those measurements. The measurements can be used to size your quilt top or block, to precisely place and quilt a design or pantograph.

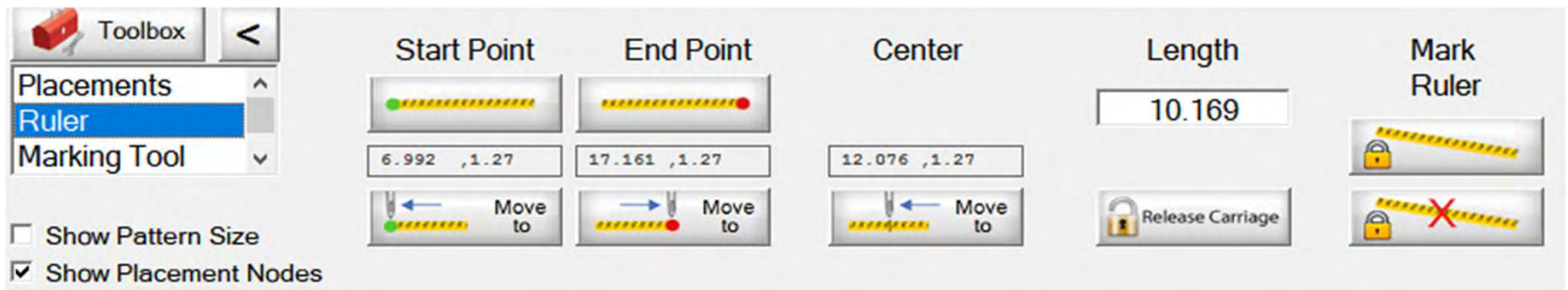

Discover the many uses of the Ruler . . .

Ruler continued...

The screenshot shows the Ruler tool interface. On the left is a 'Toolbox' with 'Placements', 'Ruler', and 'Marking Tool' options. Below it are checkboxes for 'Show Pattern Size' (unchecked) and 'Show Placement Nodes' (checked). The main interface has five columns: 'Start Point', 'End Point', 'Center', 'Length', and 'Mark Ruler'. Each column contains a ruler icon, a coordinate input field, and a 'Move to' button. The 'Length' column has a 'Release Carriage' button. A small dialog box titled 'Ruler Length' is open, showing a numeric keypad and a 'Clear' button, with the text 'Manually input length' pointing to it.

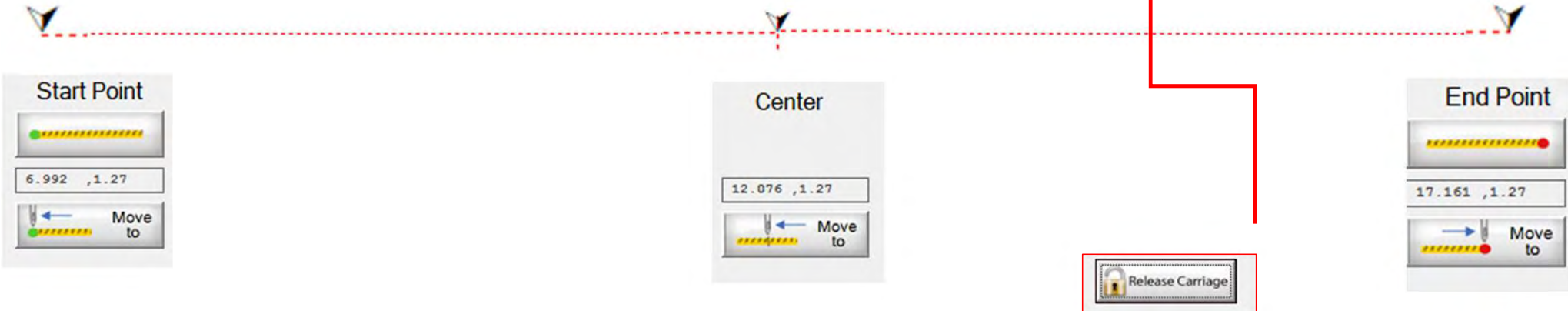

Click on "Release Carriage" then click on "Move To" either "Start Point", "Center Point" or "End Point" your machine will move to the desired point.

Ruler continued. . .

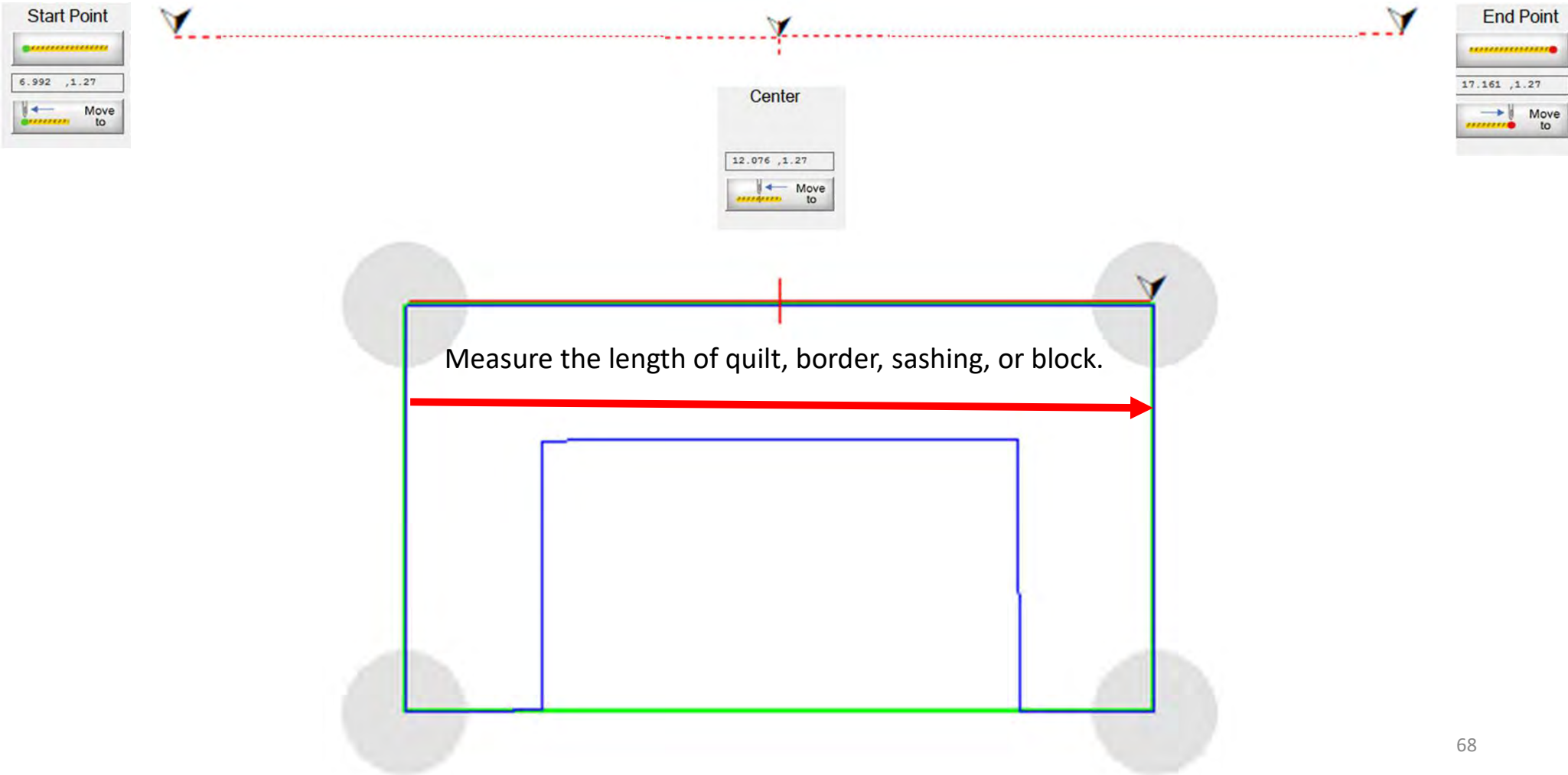

Ruler continued. . .

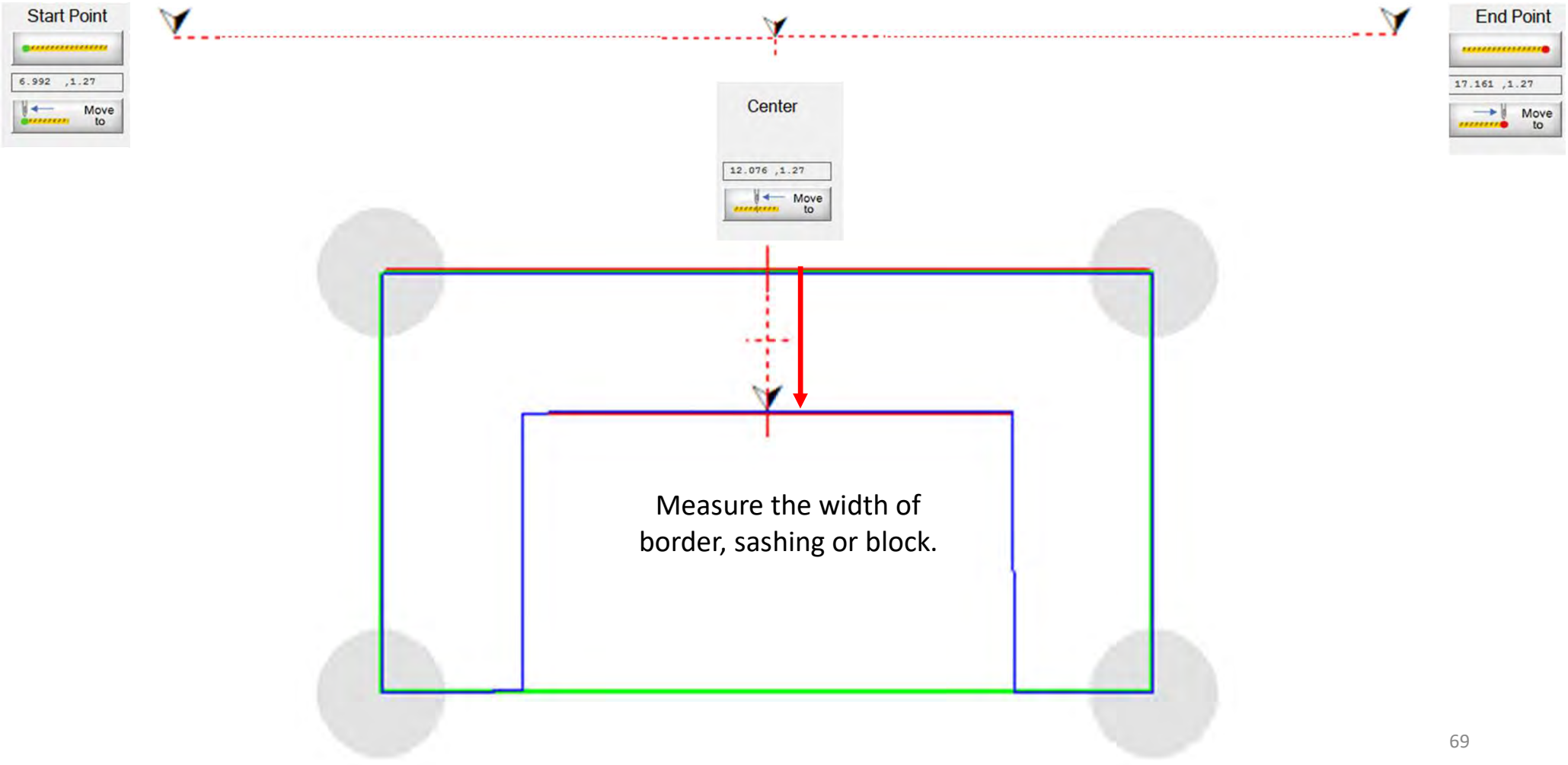

Ruler continued. . .

Start Point

6.992 ,1.27

Move to

Center

12.076 ,1.27

Move to

End Point

17.161 ,1.27

Move to

center

Use the mark ruler to apply measurements, to help your find exact center of border, sashing or block.

Ruler continued. . .

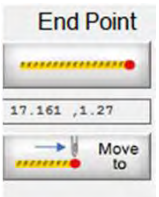
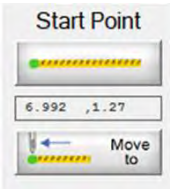

Mark ruler will let you apply several different measurements. Here are a few ways to use it to find your center of your block and now your can place your design using “One Point” placement “Center” fill.

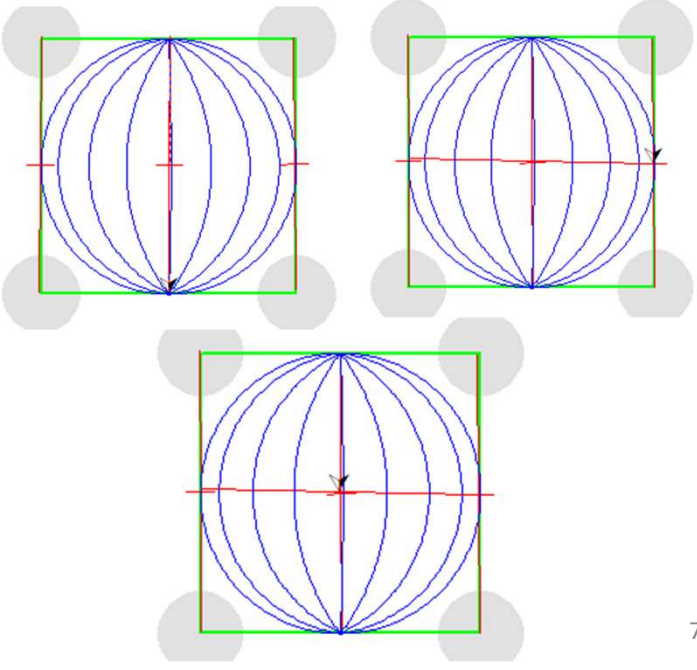
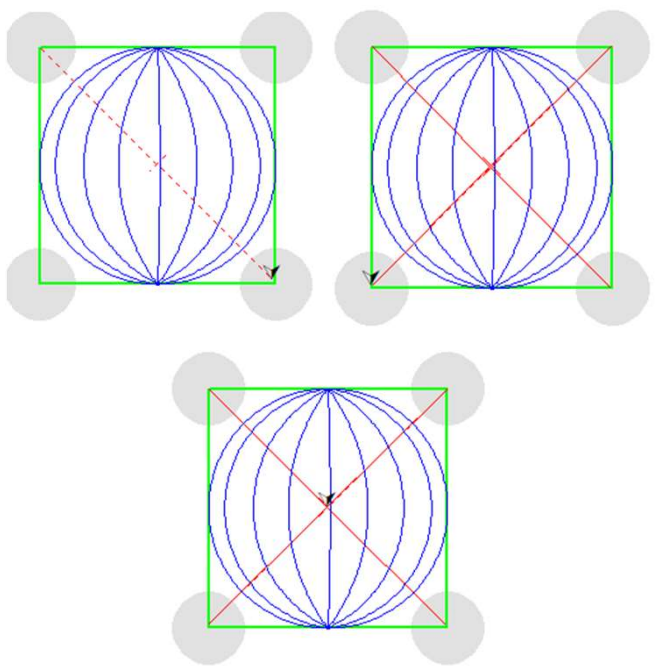

TOOLBOX

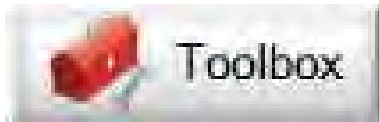

SET SAFE AREA

Click to Set
the Safe Area

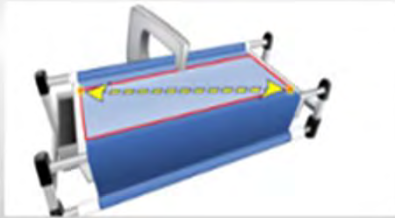

Safe Area WIDTH (Limit Range: 8 to 150)

150 ← Clear

7	8	9	
4	5	6	
1	2	3	
Close	0	.	OK

Enter the frame's sewing area WIDTH

Safe Area HEIGHT (Limit Range: 2 to 30)

30 ← Clear

7	8	9	
4	5	6	
1	2	3	
Close	0	.	OK

Enter the frame's sewing area HEIGHT

RESET YOUR QUILTING AREA, WHICH IS DETERMINED BY WIDTH OF YOUR QUILT TOP AND THE DEPTH/THORAT OF YOUR MACHINE.

“Select & Sew” Power Placement continued. . .

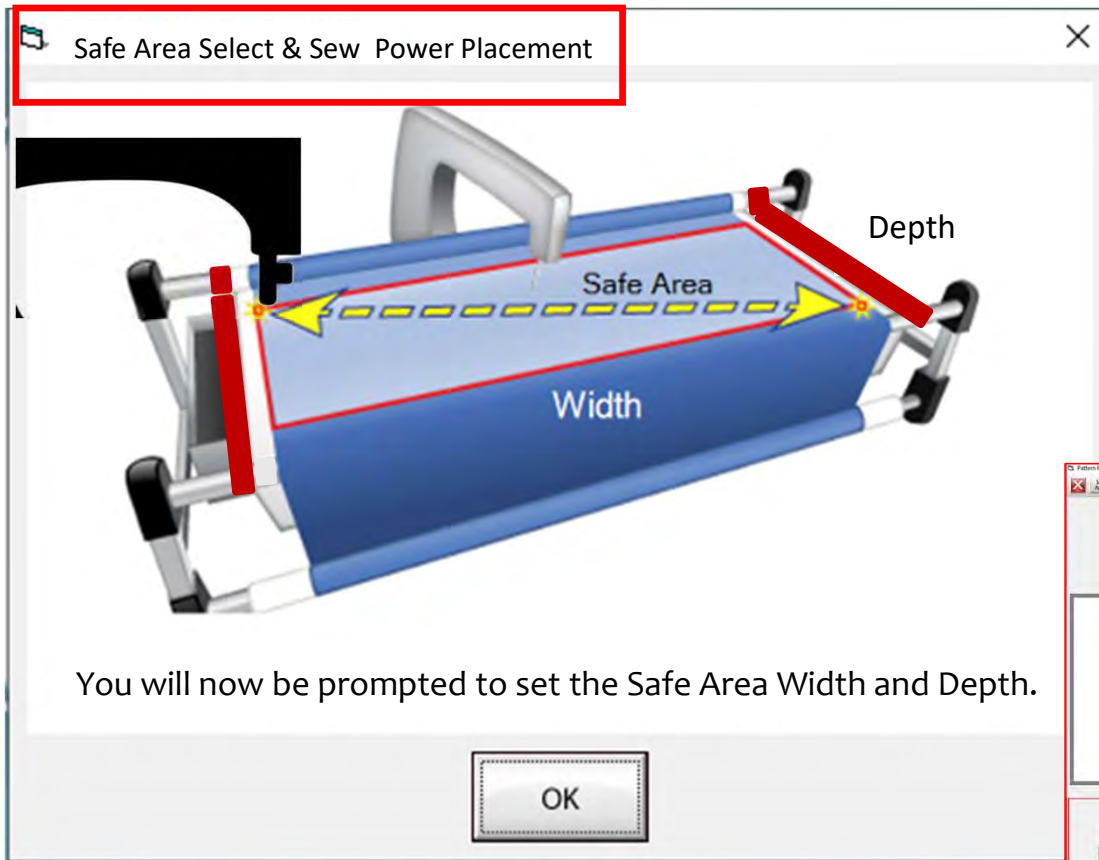

The “Safe Area” is your “quiltable,” quilting area on your quilt top. Move your machine to the “TOP LEFT of your Quilt Top corner (edge) and tap on the screen in the “Click to Set the Safe Area.” You have now set your “Safe Area” WIDTH.

*Note: Select & Sew Power Placement Width (the width of your “Quilt Top” if you are putting the size in manually.

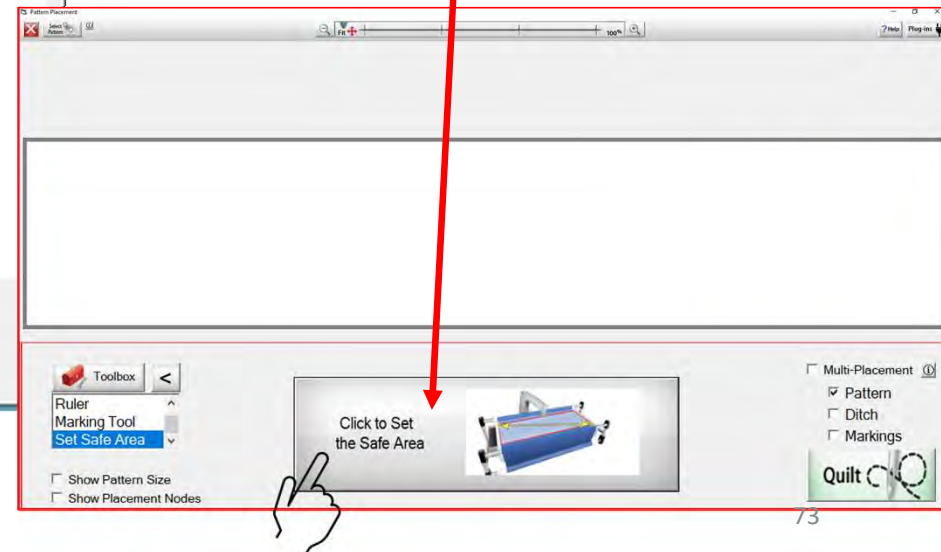

“Select & Sew” Power Placement continued. . .

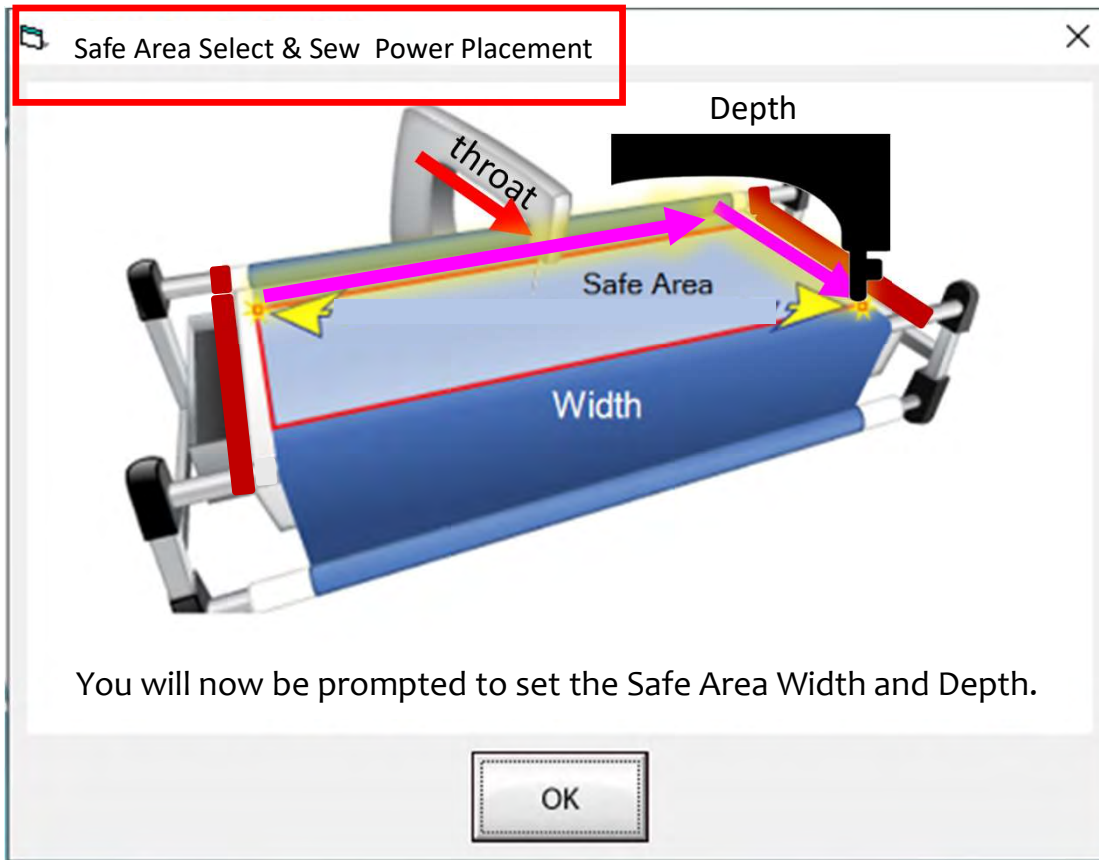

*Note: Select & Sew Power Placement Depth (the Depth of your “Machine Throat”) if you are putting the size in manually.

“Safe Area” “DEPTH” is your “quiltable,” quilting area determined by the arm (throat length) of your machine. Move your machine the width of the quilt top to the right edge, then move the machine as far forward as you can towards the front of the frame as far forward as the machine will extend to the “BOTTOM RIGHT” of your Quilt Top (edge) and tap on “Click to Set the Safe Area” on the screen.

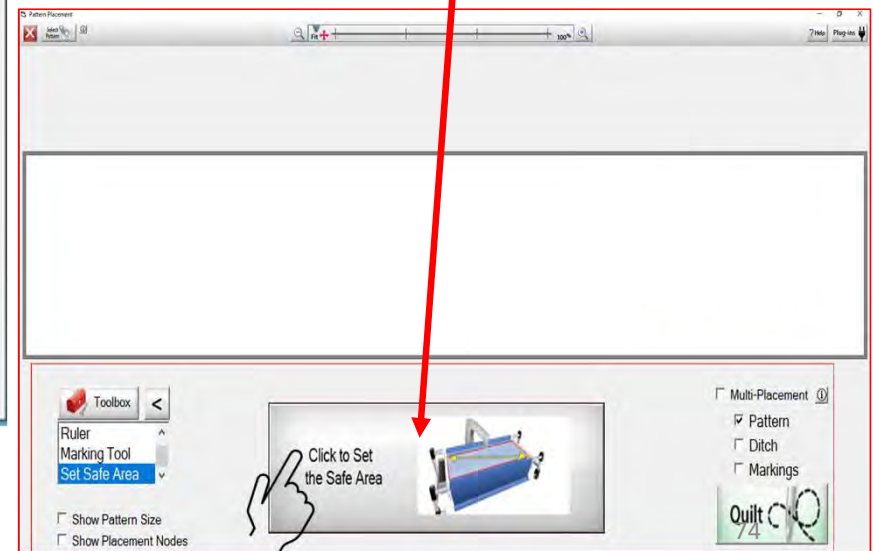

Select & Sew Power Placement

Allows you to customize the quilting pattern/design to match the piecing of your block, triangle, hexagon or circle.

Explore different placement methods using:

- **One Point**
- **Two Point**
- **Block**
- **Four Points**
- **Tilted Block**
- **Triangle**
- **On Point**
- **Cube Side or Diamond**

Click on “Select & Sew” and let’s discover each placement method, and how to use them.

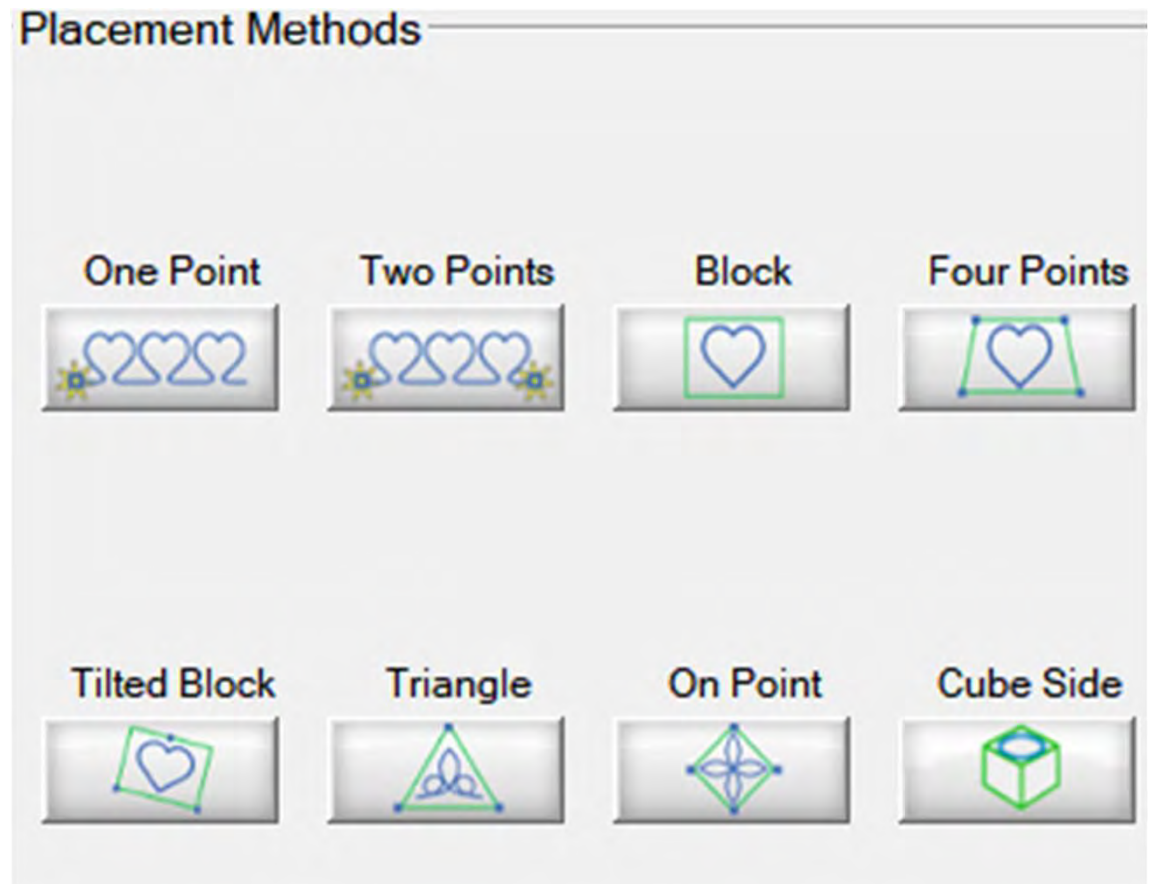

Select & Sew Power Placement continued...

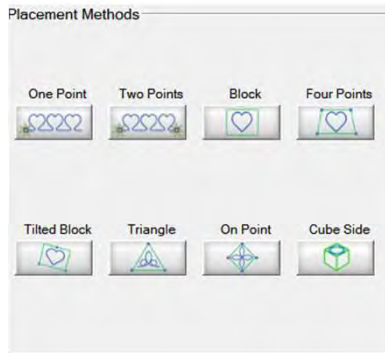
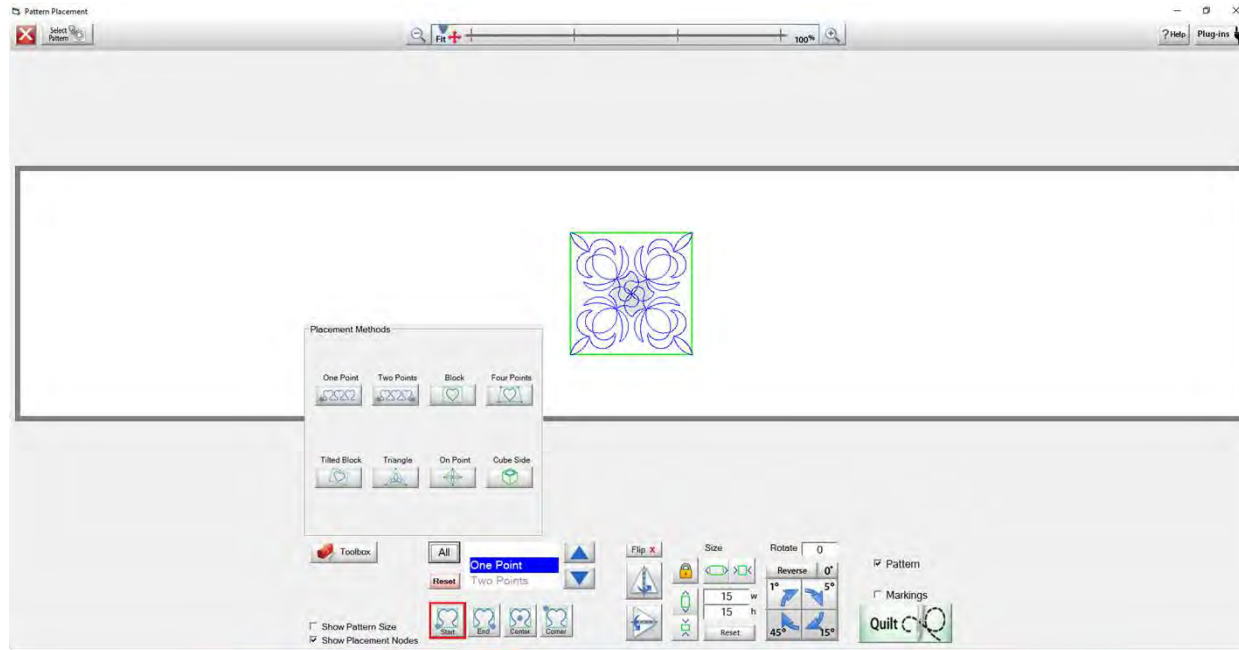

By selecting "All" the placement methods will pop up tap or click on the placement screen to make it disappear



To navigate through the placement methods use the up and down arrow keys.

Select & Sew Power Placement continued. . .

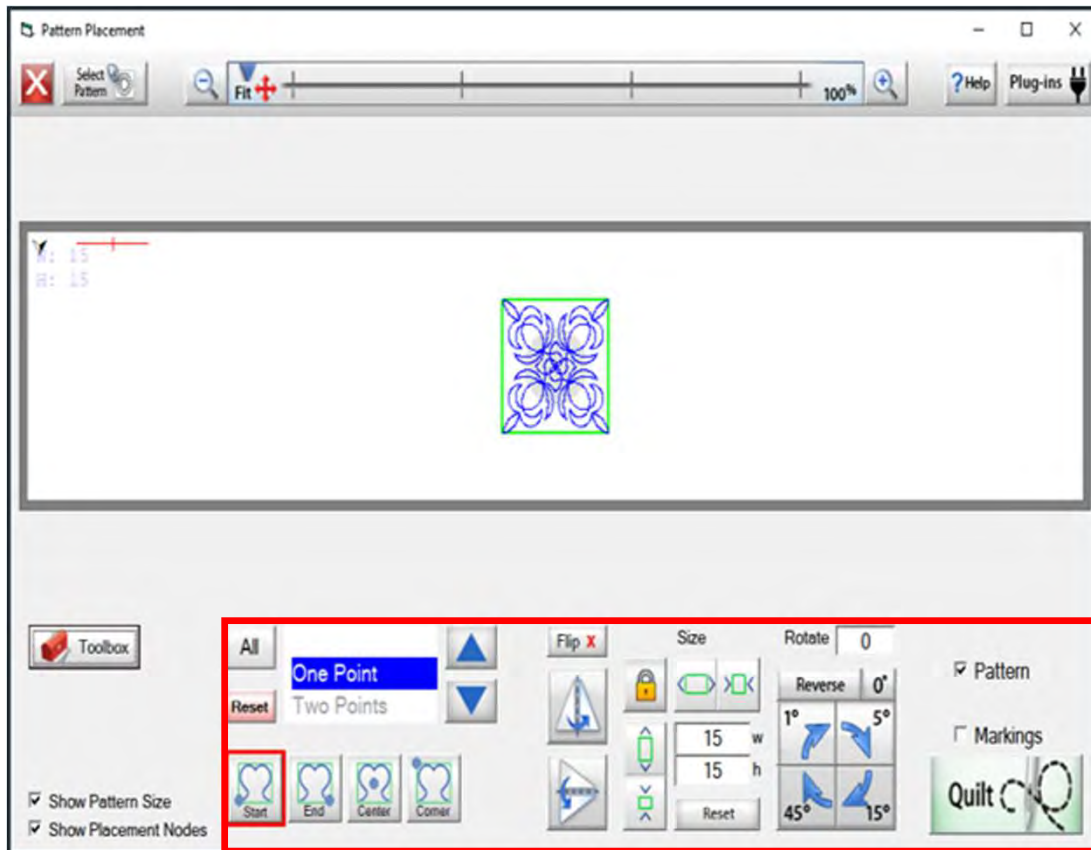

In this section we will discover each power point placement. Learn what each button/icon does and how to use them within each of the power placement modes.

- Flip your pattern/design horizontal or vertical
- Size your pattern/design to fit your block dimension
- Rotate your design to the angle of your block

One Point Block Placement

Pattern Placement

Select Pattern

Fit + 100%

? Help Plug-Ins

“One Point” power placement uses one/single point of reference on your quilt/block to place your pattern/design.

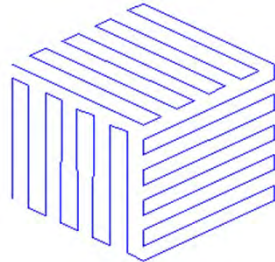

Toolbox

All One Point Two Points

Reset

Show Pattern Size

Show Placement Nodes

Flip X

Size

Rotate 0

Reverse 0°

1° 5°

45° 15°

Pattern

Markings

Quilt

One Point Block Placement

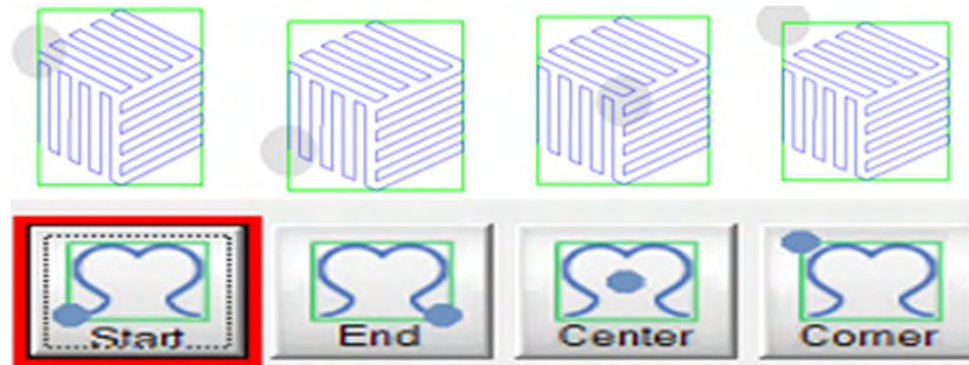

The positioning tabs help you easily find which “One Point” position to place your design. Choose “Start”, “End”, “Center” and “Corner” positions.

One Point Block Placement continued. . .



“Start Point” position is used to match up the end point with the starting of another pattern/design.



“End Point” position is used to find the end position to match the starting position of your pattern/design.

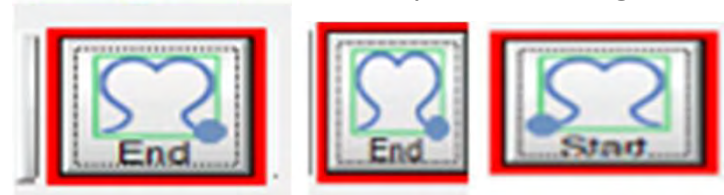

“Center Point” placement position helps place and center your pattern/design on your quilt block.

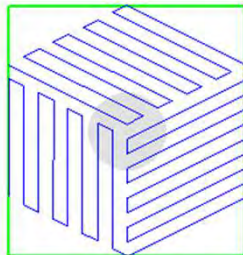

“Corner Point” position places your pattern/design across the width of your quilt block without altering or stretching your pattern/design.

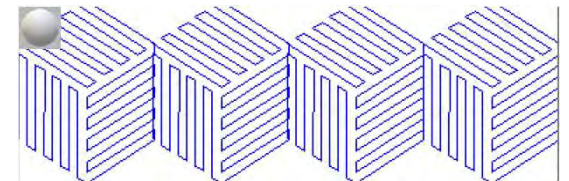

One point power block placement continued. . .

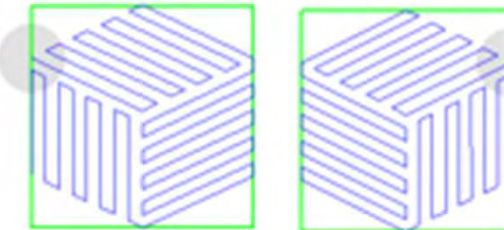
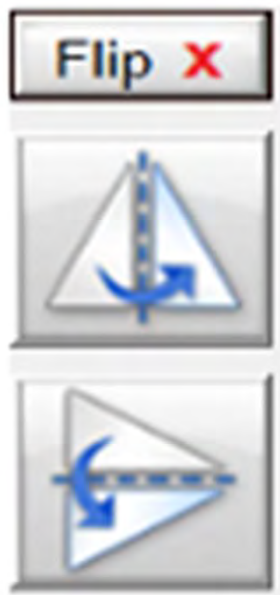
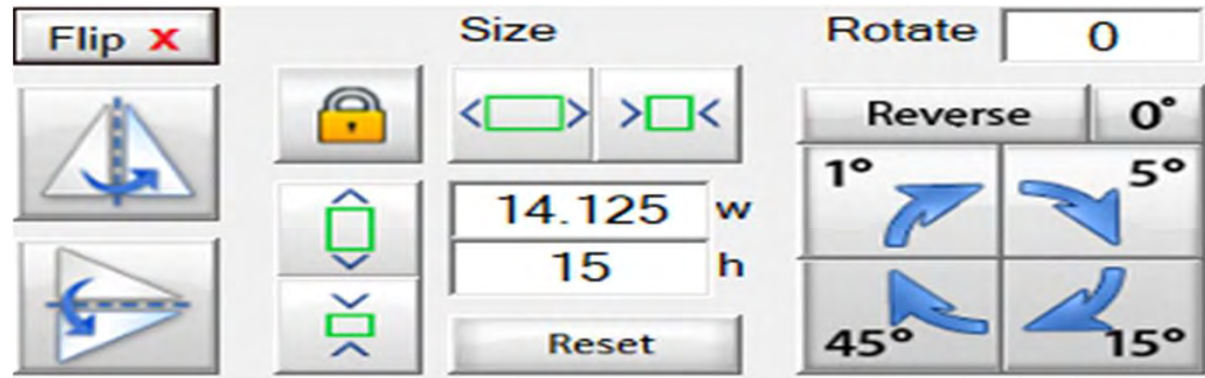

Flip your design horizontally

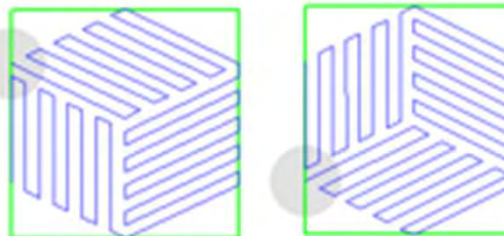

Flip design vertically

One point power block placement continued. . .

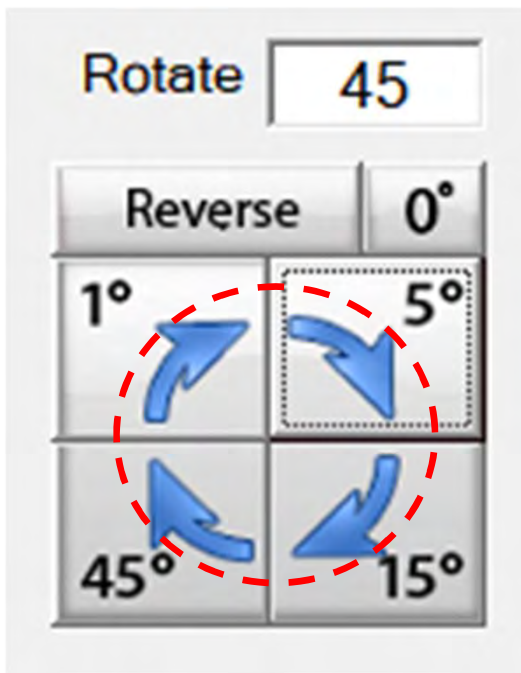

Rotate your pattern/design 1°, 5°, 15° or 45° using the rotate to set your pattern/design to the desired angle.

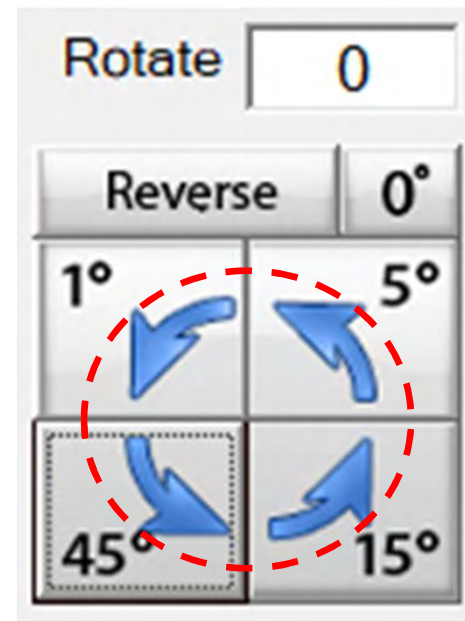
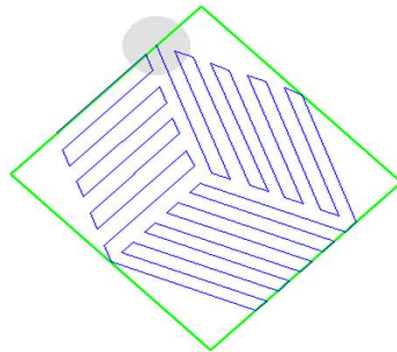

Reverse to rotate back to a previous setting or angle

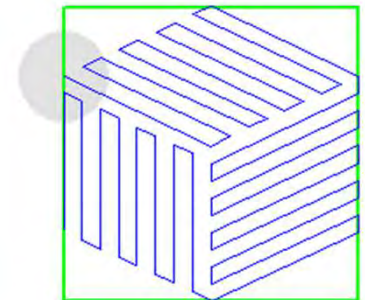

One point power block placement continued. . .

When locked the size of your block will grow proportional /evenly.

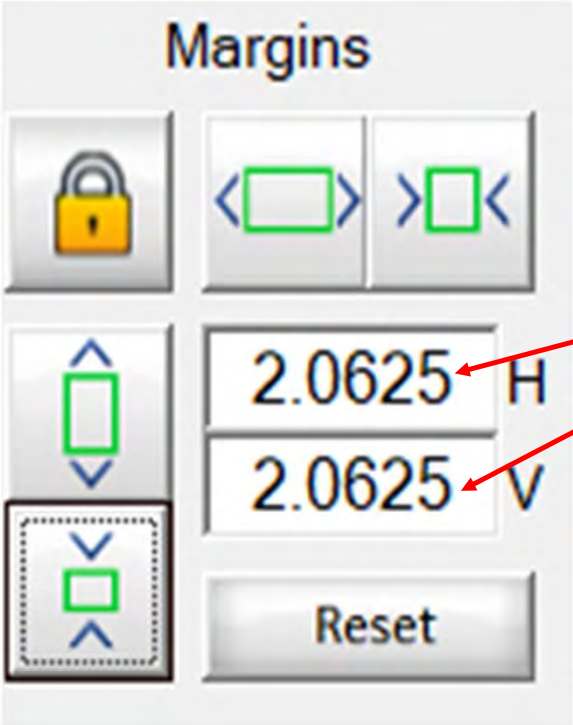

Vertical/height

Horizontal/width

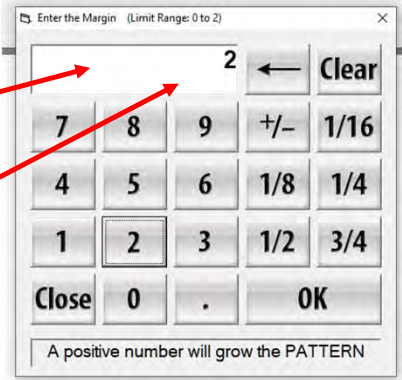

When you tap on the numbers of the width and height you can manually change your size

Reset will reset you block to its original size

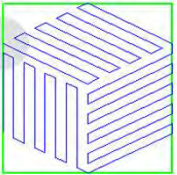

One point power block placement continued. . .

Margins

0 H
0.9375 V
Reset

Unlock to resize your pattern/design vertical/height.

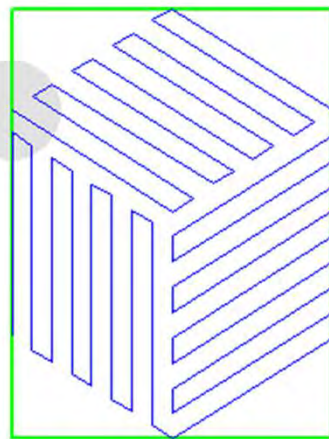

Margins

2.0625 H
0 V
Reset

Unlock to resize your pattern/design horizontal/width.

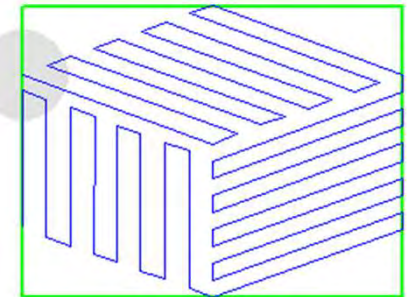

Two Point Power Block Placement

Pattern Placement

W: 20.424
H: 15.000

“Two point” power placement places a pattern/design between two existing quilted designs.

Toolbox

All One Point
Two Points
Block

Reset

Start Point End Point Stretch Fit

Flip X

Pattern

Markings

Quilt

Show Pattern Size
Show Placement Nodes

Two Point Power Block Placement continued. . .

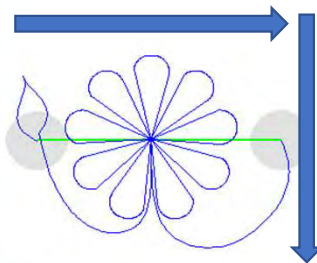

“Stretch”, stretches your design to the edge of your block. Stretch will stretch the design and not keep it proportional.

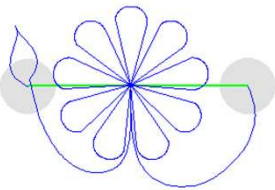

“Fit”, fits your design within the parameters of your block without stretching it, it keeps it proportional.

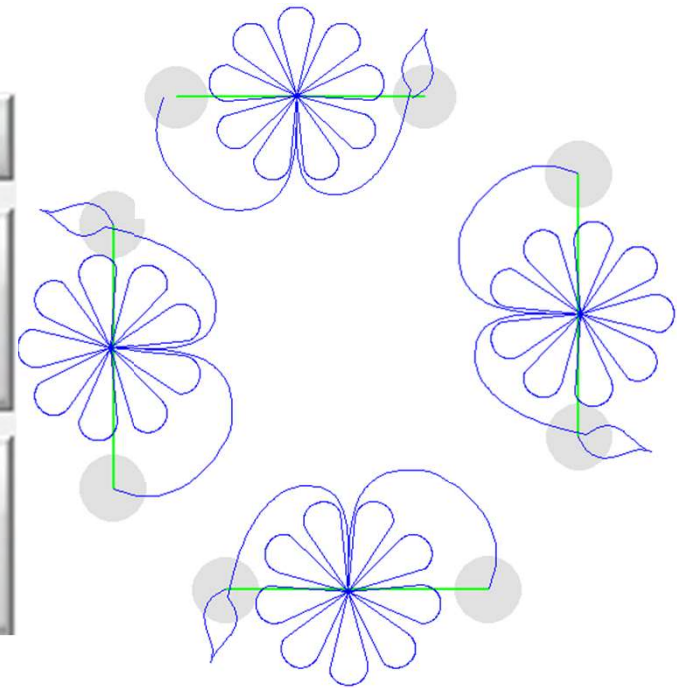

Flip your design for a top to bottom, side to side to keep your eyes looking towards the center of your Quilt.

Two Point Power Block Placement continued. . .

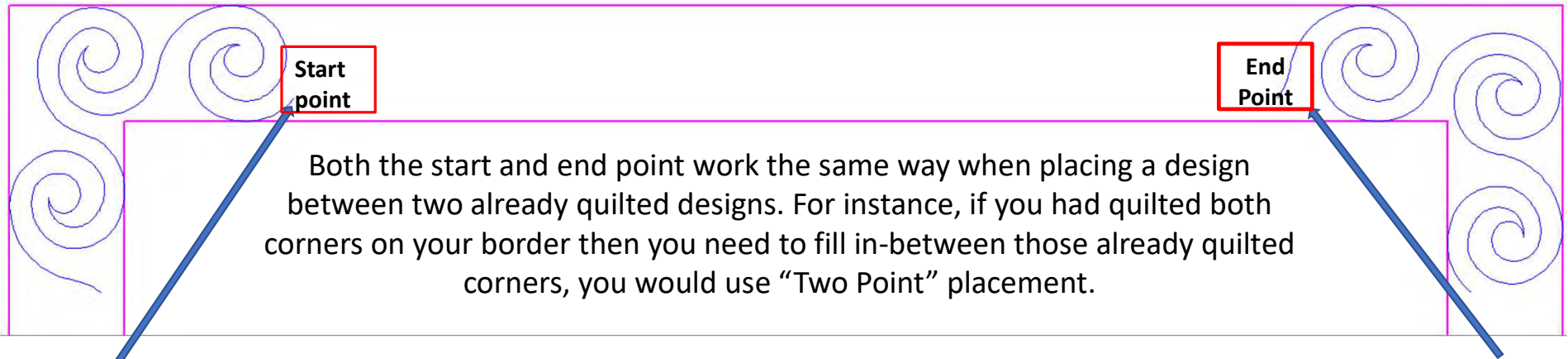

Start point will anchor the pattern/design using the start point.



End point will anchor the pattern/design using the end point.



Two Point Power Block Placement continued. . .

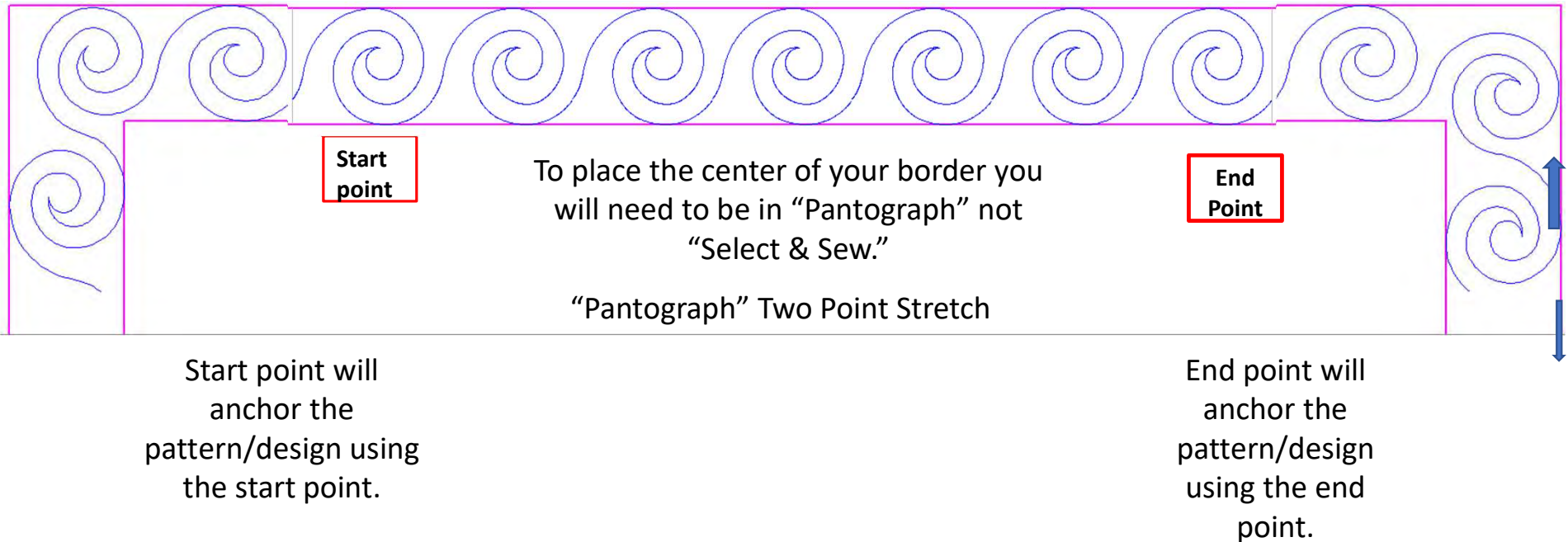

To learn how the "Two Point" process works for borders go to the "Borders and Corners" section of your help files.

Block Power Placement

Pattern Placement

Fit 100%

Help Plug-ins

W: 37.489
H: 34.633

“Block” placement places a pattern/design using two points, the top left of your quilt block and the bottom right.

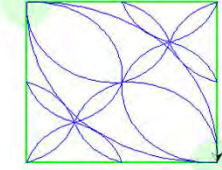

Toolbox

All Two Points
Block
Reset Four Points

Flip x

Margins

Rotate 0

Reverse 0°

1° 5°

45° 15°

Reset

Pattern
 Ditch
 Markings

Quilt

Show Pattern Size
 Show Placement Nodes

Stretch Fit

Block Power Placement continued. . .

Stretches

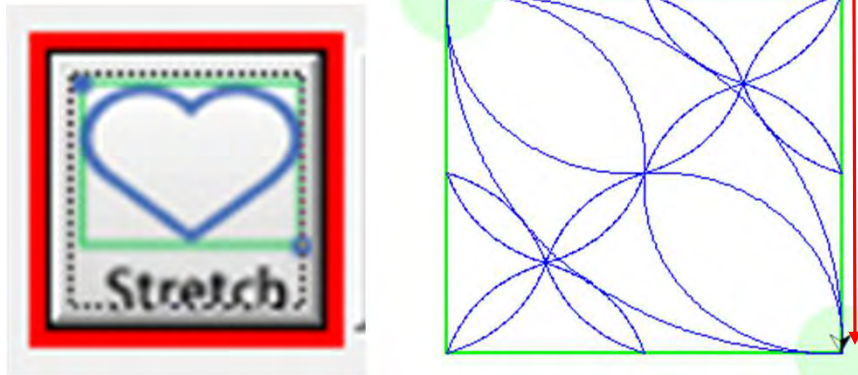

“Stretch”, stretches your design to the edge of your block. Stretch will stretch the design and not keep it proportional.

Proportional
Fit

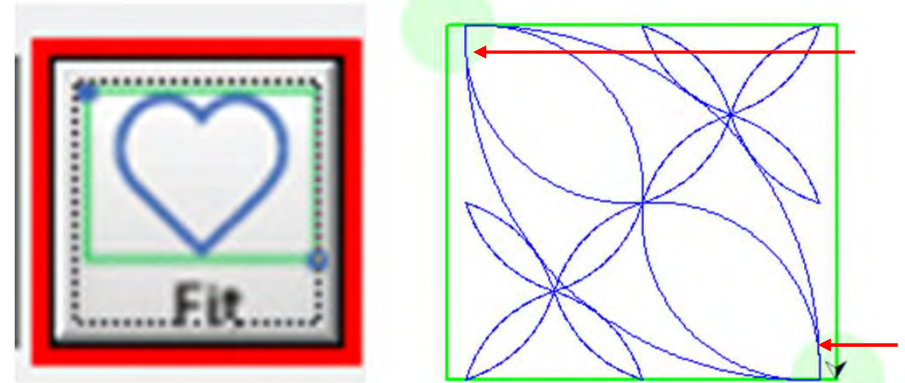

“Fit”, fits your design within the parameters of your block without stretching it, it keeps it proportional.

Block Power Placement continued. . .

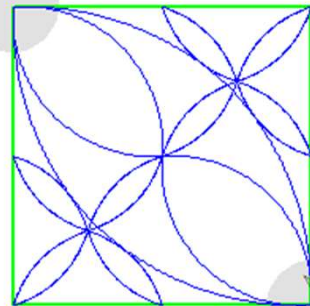
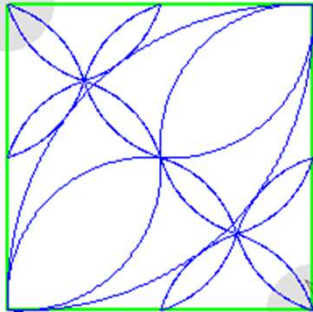

Horizontal flip helps the design sew to draw your eye in a desired direction.

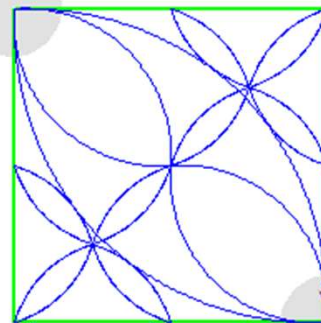
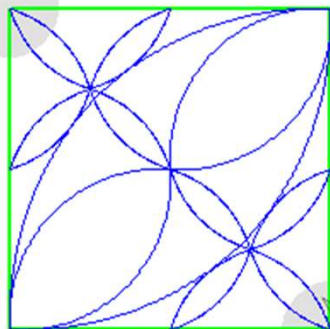

Vertical flip helps to draw your eyes in a desired direction.

Block Power Placement continued. . .



Example of
"Flipping a design"

Block Power Placement continued. . .



Rotate pattern/design 1° , 5° , 15° or 45° to fit onto a vertical block. Rotating also helps to draw the eyes in a desired direction.

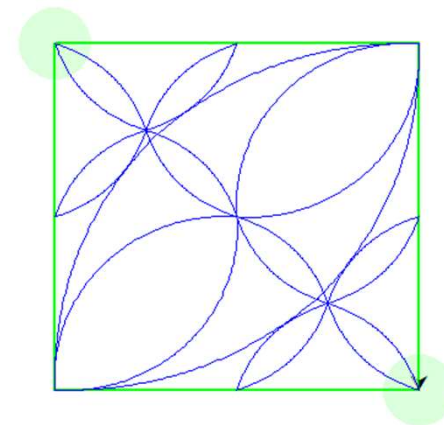

Reverse to rotate back.

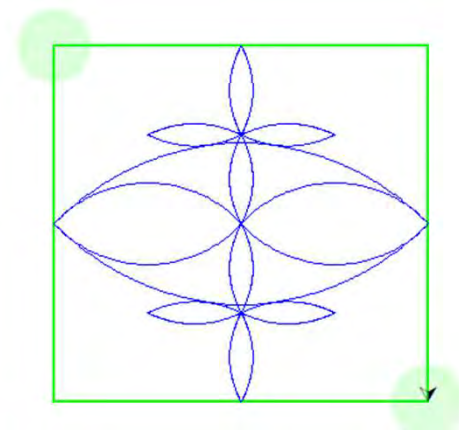
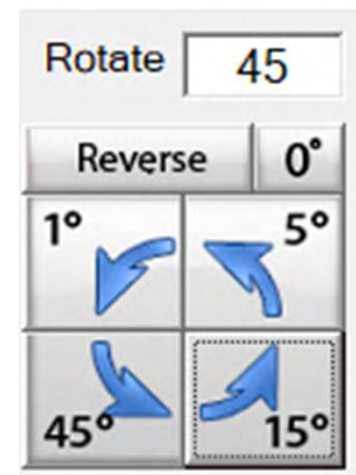

Block Power Placement continued. . .

“Margin” is the space between your quilting pattern/design and the edge of the seam.

“Horizontal Margin”

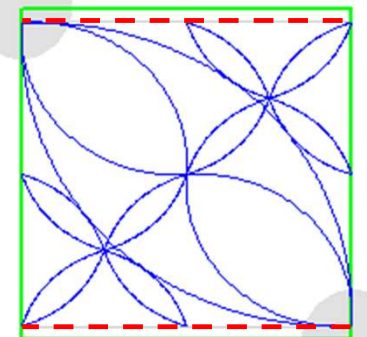
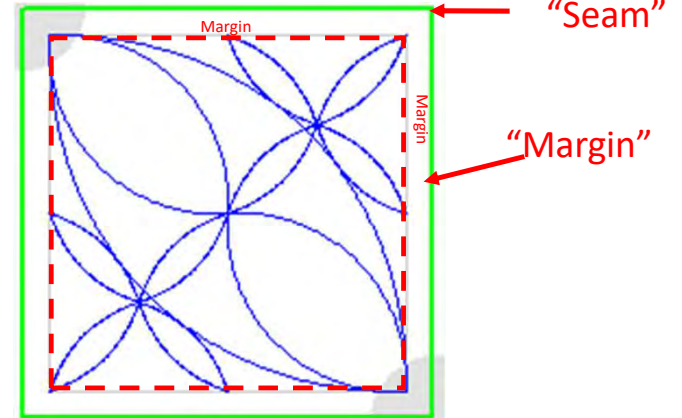
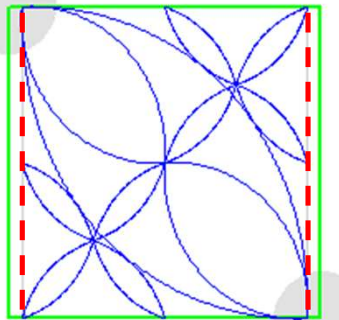

“Vertical Margin”

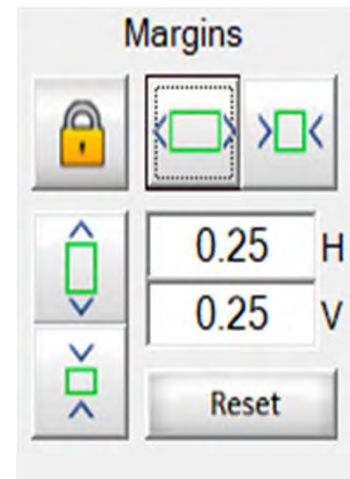

“Locked Margin” will keep the design in proportion.

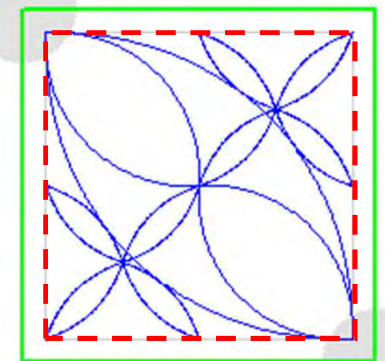

Four Point Power Placement

Pattern Placement

Select Pattern

Fit + 100%

Help Plug-ins

Four Point Power Placement, places the pattern/design using four different placement points on your quilt block.

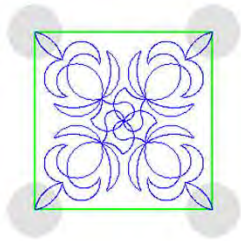

The image shows a quilt block design with four placement points. The design is a square block with a central floral motif. The four placement points are located at the corners of the block, indicated by small grey circles. The block is outlined in green.

Toolbox

All Block
Four Points
Reset Tilted Block

Show Pattern Size
Show Placement Nodes

Stretch Fit

Flip X

Margins

Rotate 0

Reverse 0°

1° 5°

45° 15°

Reset

Pattern
Ditch
Markings

Quilt

Four Point Power Placement continued. . .

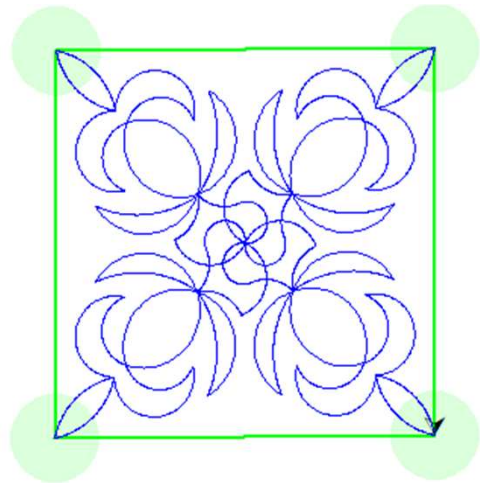

“Stretch”, stretches your design to the edge of your block. Stretch will stretch the design and not keep it proportional.

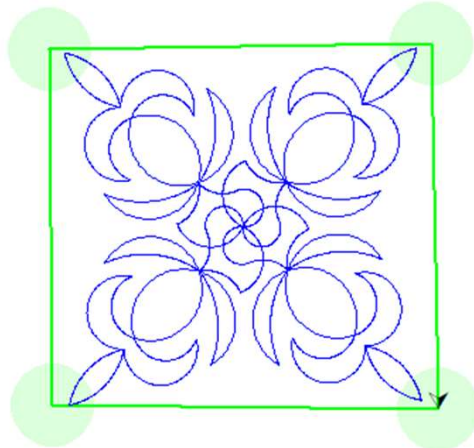

“Fit”, fits your design within the parameters of your block without stretching it, it keeps it proportional.

Four Point Power Placement continued. . .

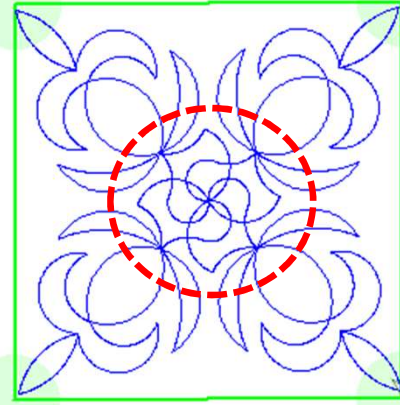
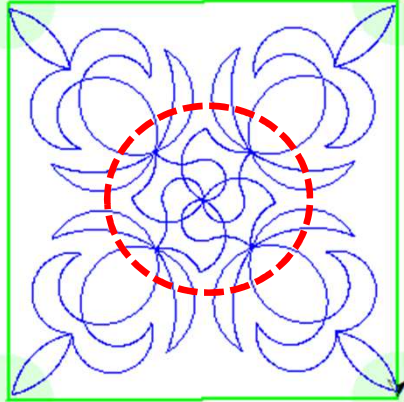

Flip your design Horizontal, notice the center of this design has changed direction horizontally .

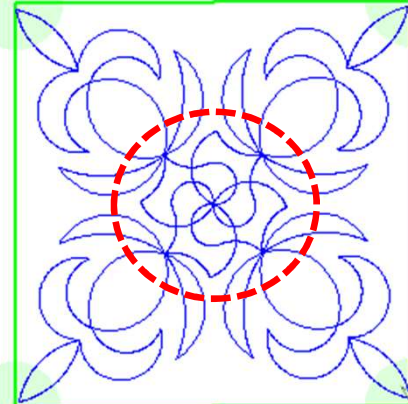
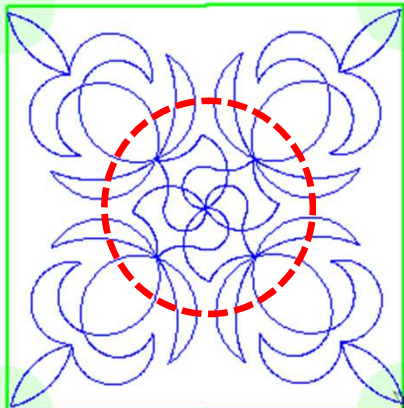

Flip your design vertical, notice the center of this design changed directions because we flipped it vertically.

Four Point Power Placement continued. . .

“Margin” is the space between your quilting pattern/design and the edge of the seam.

“Locked Margin” will keep the design in proportion.

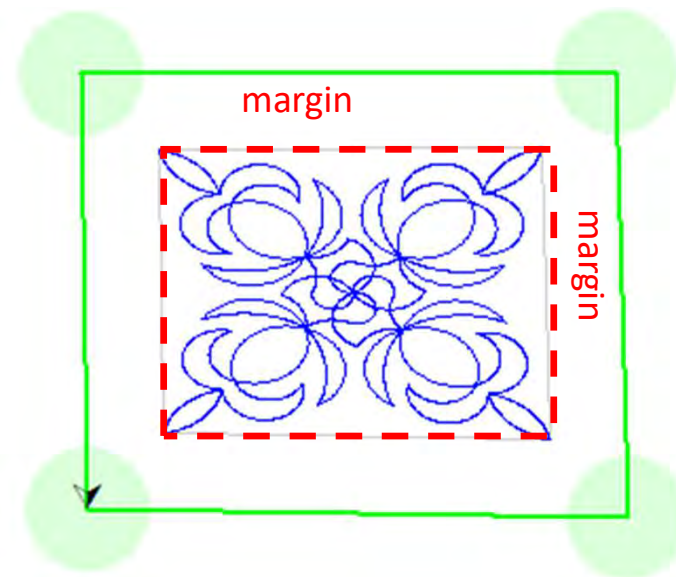
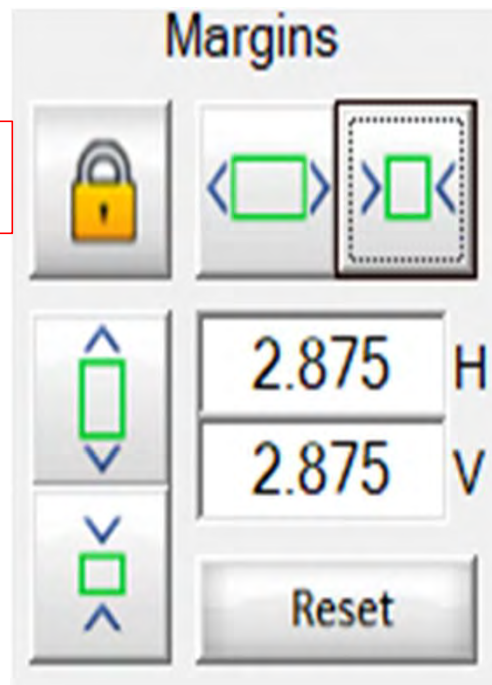

“Reset” sets design to original size

Four Point Power Placement continued...

“Margin” is the space between your quilting pattern/design and the edge of the seam.

Horizontal margin

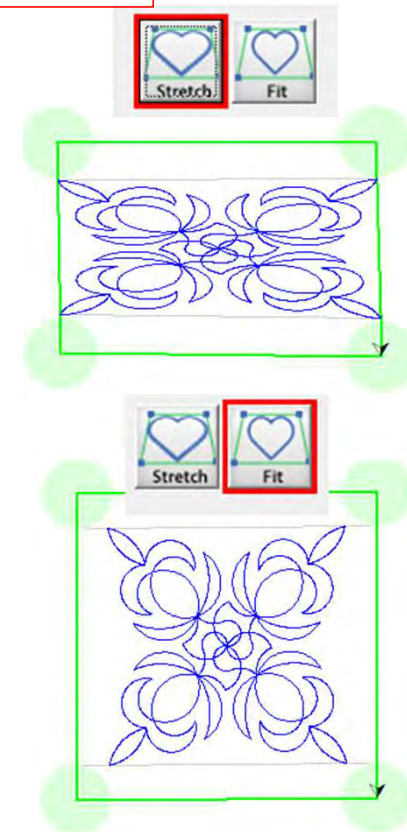
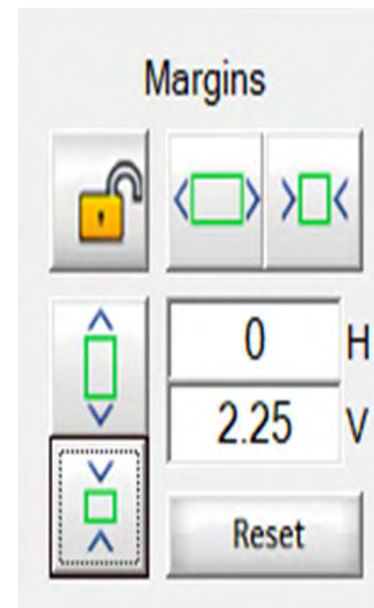
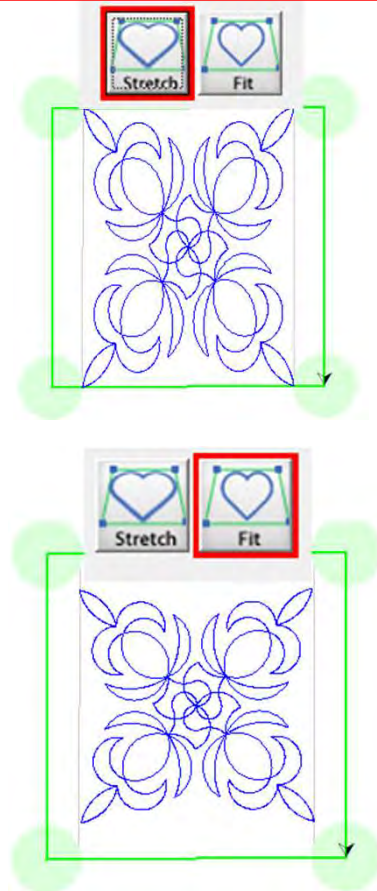
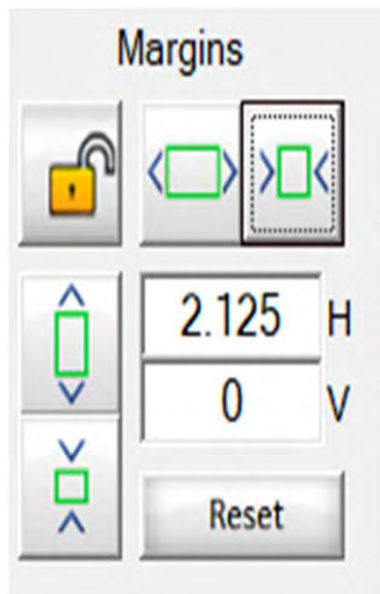

Vertical margin

Four Point Power Placement continued. . .

Rotate your pattern/design 1°, 5°, 15° or 45° using the rotate to set your pattern/design to the desired angle.



Block four point design.

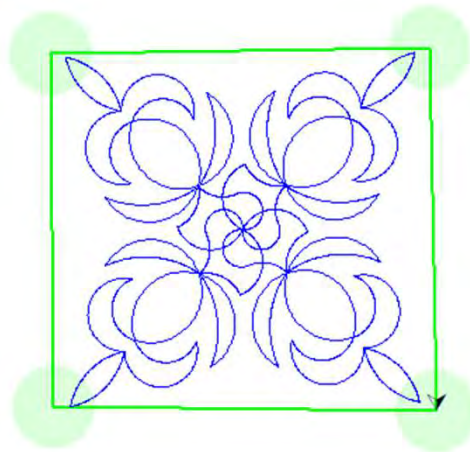

Rotate block design 45° to set the block on point for a different look.

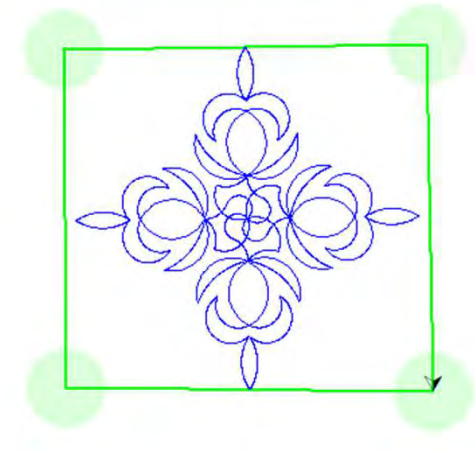

Reverse, change directions

Block Power Placement continued. . .

“Margin” is the space between your quilting pattern/design and the edge of the seam.

“Horizontal Margin”

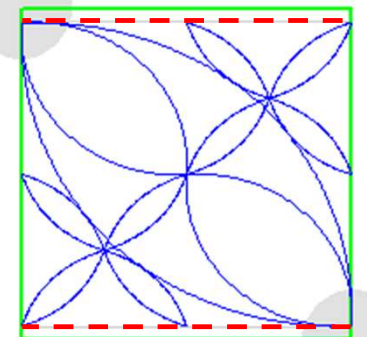
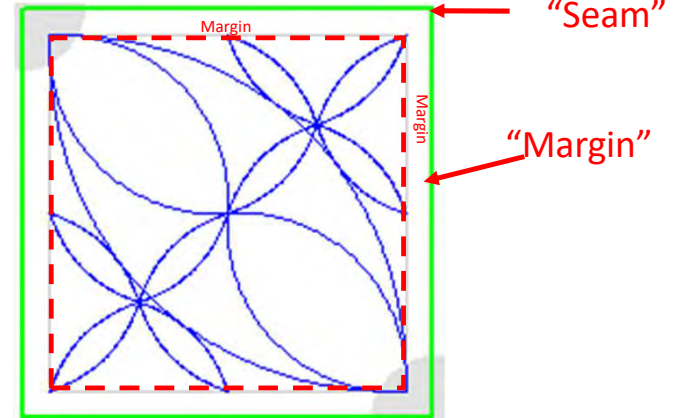
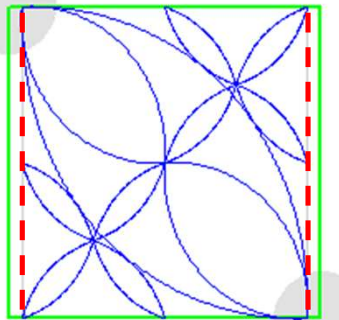
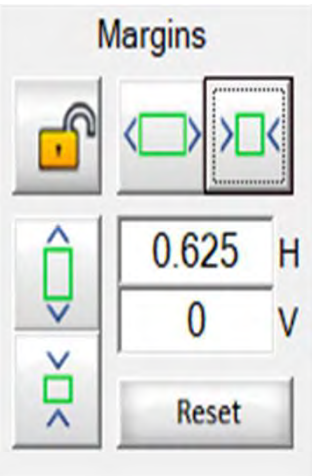

“Vertical Margin”

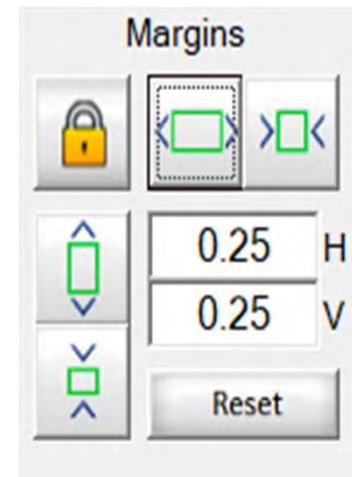

“Locked Margin” will keep the design in proportion.

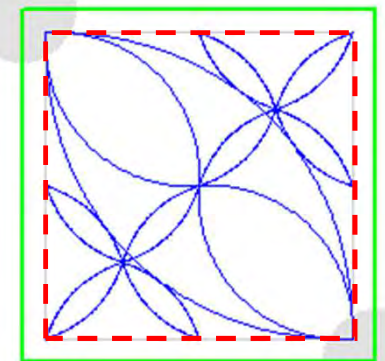

Tilted Block Power Placement

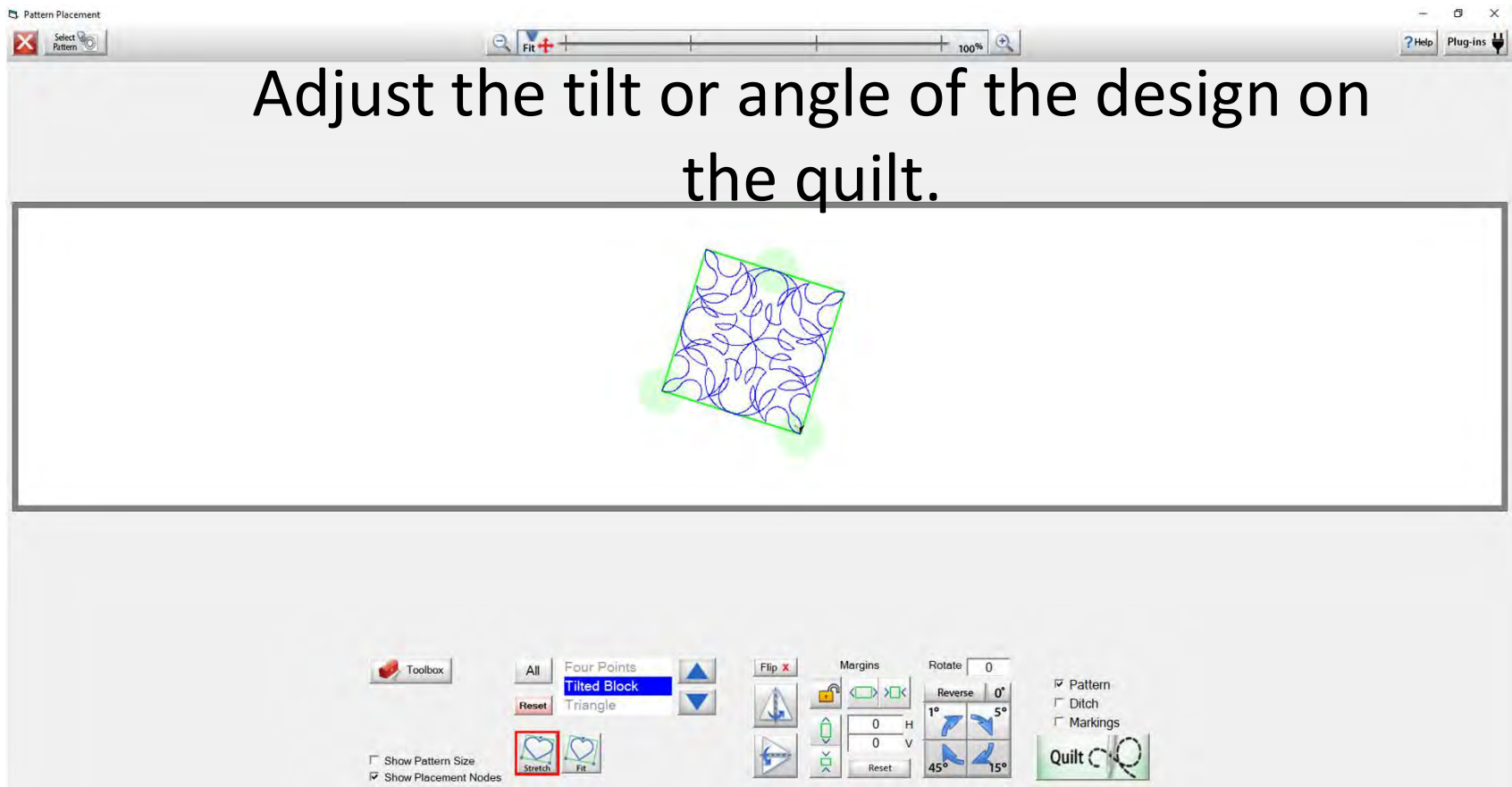

Tilted Block Power Placement continued. . .

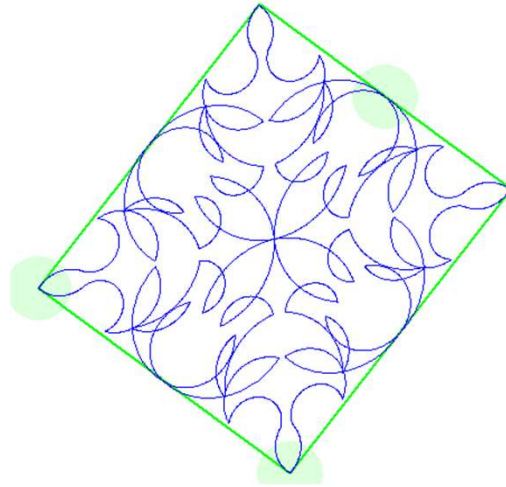

“Stretch”, stretches your design to the edge of your block. Stretch will stretch the design and not keep it proportional.

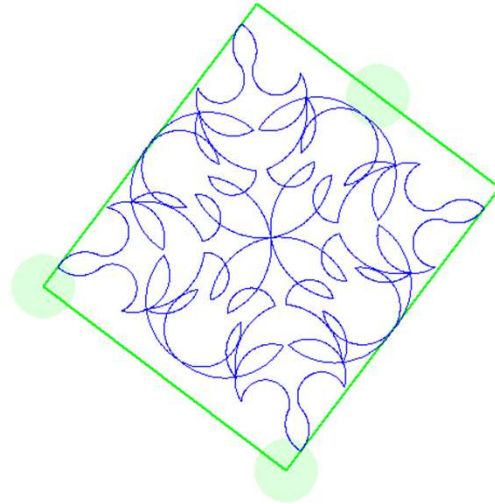

“Fit”, fits your design within the parameters of your block without stretching it, it keeps it proportional.

Tilted Block Power Placement continued. . .

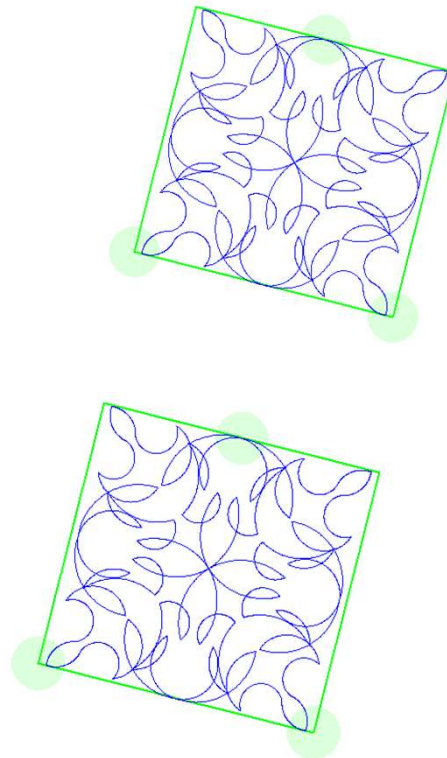

Some designs are designed to look the same. If you flip horizontal or vertical, the design looks the same from any direction.

Tilted Block Power Placement continued. . .

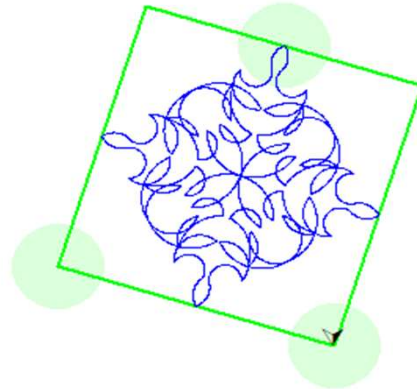
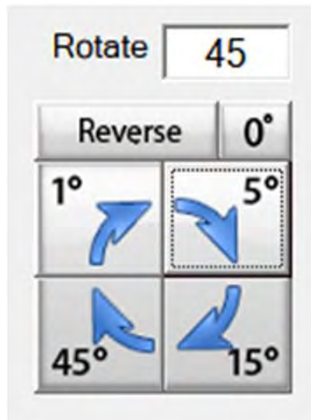

Reverse to rotate back

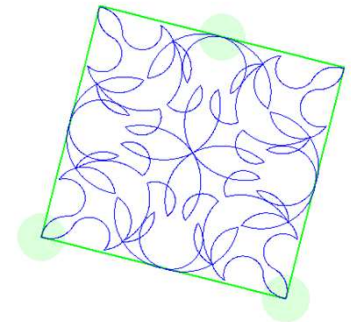

“Rotate” your pattern/design 1° , 5° , 15° or 45° using the rotate to set your pattern/design to the desired angle onto your quilt block. “Reverse Rotate” will rotate your design using the 1° , 5° , 15° or 45° back to original tilt.

Tilted Block Power Placement continued. . .

“Margin” is the space between your quilting pattern/design and the edge of the seam.

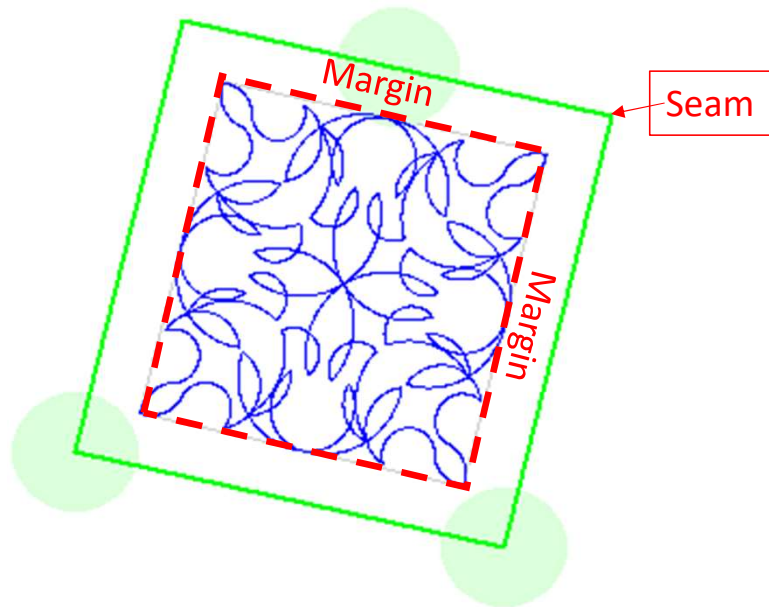
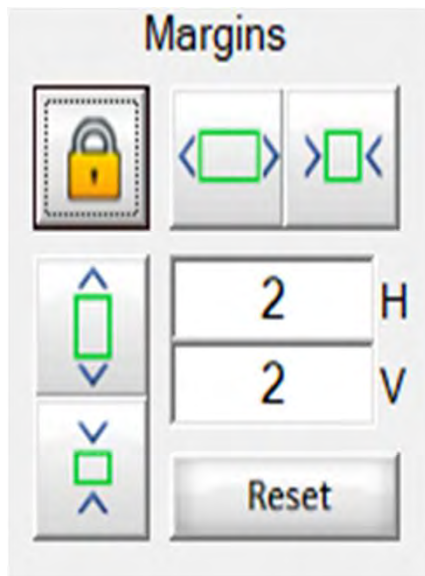

Margins are locked in tilted block placement. Decreasing the margin will decrease the size of the block proportionally.

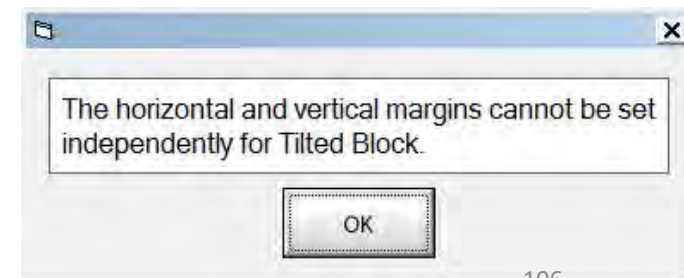

Triangle Block Power Placement

Pattern Placement

Select Pattern

Fit + 100%

Help Plug-ins

Place your triangle design using the equilateral placement or the non equal triangle onto your triangle quilt block.

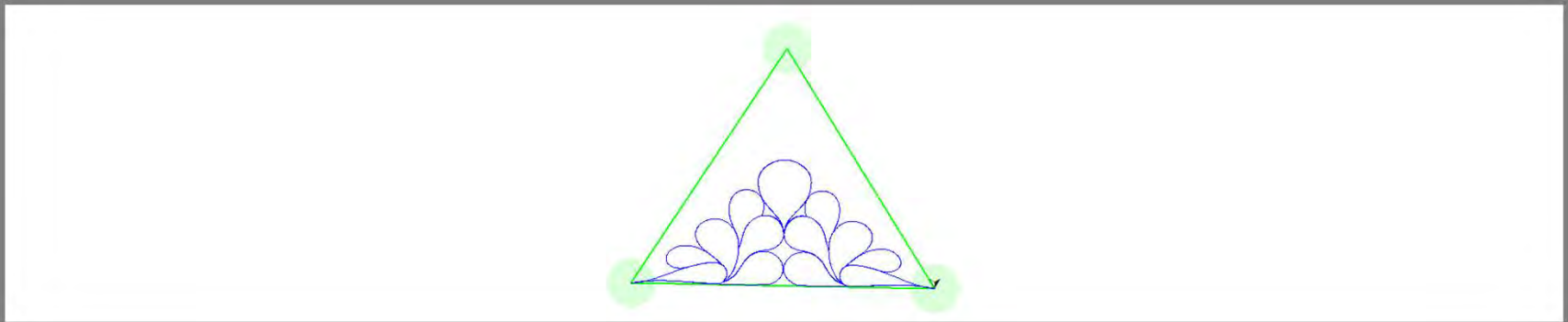

Toolbox

All Tilted Block
Triangle
Reset On Point

Show Pattern Size
Show Placement Nodes

Stretch Fit

Flip X

Margins

0 H
0 V
Reset

Pattern
Ditch
Markings

Quit

Triangle Block Power Placement continued. . .

Most triangle designs will not be made for using the
“Equilateral/ 60° triangle.

Stretch Fit

Stretch Fit

“Equilateral/60° Triangle symbol”

Non-Equilateral Triangle, using “Equilateral/ 60° Triangle” placement, the proportions are off.

Triangle Block Power Placement continued...

Equilateral/ 60° Triangle placement stretch. "Stretch", stretches your design to the edge of your block. Stretch will stretch the design and not keep it proportional.

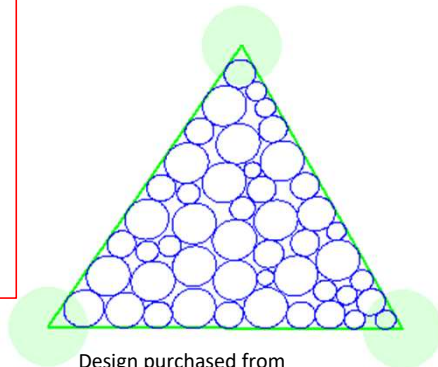

Design purchased from digitizedquiltingpatterns.com/

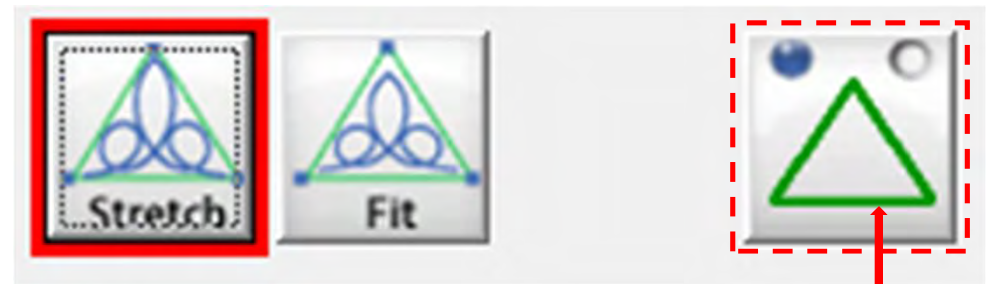

"Equilateral/60° Triangle symbol"

Equilateral/ 60° Triangle placement fit. "Fit", fits your design within the parameters of your block without stretching it, it keeps it proportional.

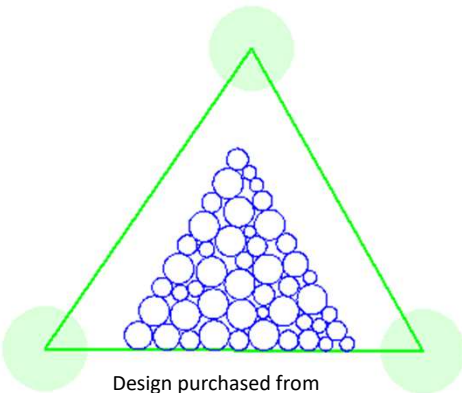

Design purchased from digitizedquiltingpatterns.com/



Triangle Block Power Placement continued. . .

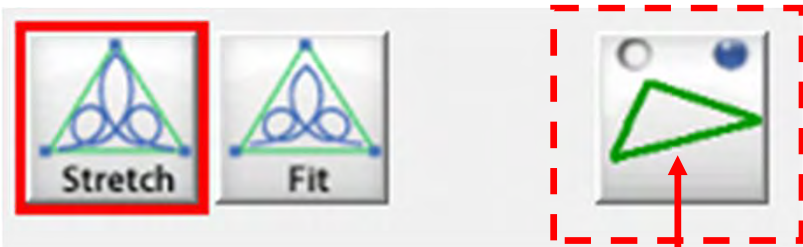

Non-Equilateral Triangle or
"Triangle" symbol.

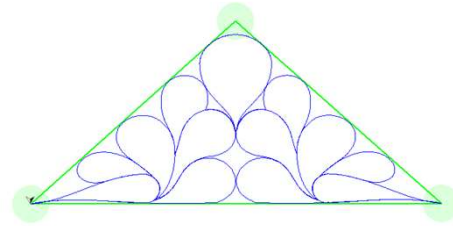

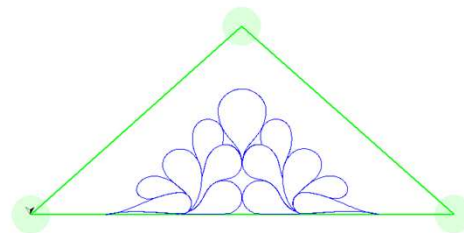

Triangle placement "Stretch," stretches your design to the edge of your block. Stretch will stretch the design and not keep it proportional.

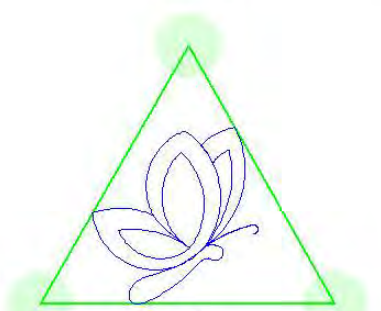
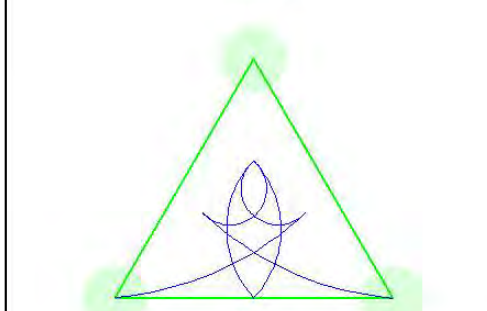

Triangle placement "Fit," fits your design within the parameters of your block without stretching it, it keeps it proportional.

Triangle Block Power Placement continued. . .

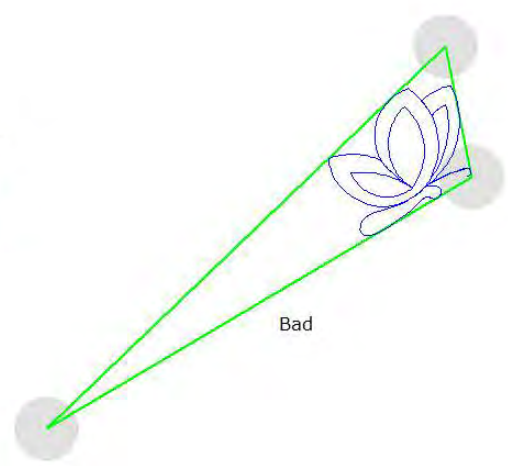
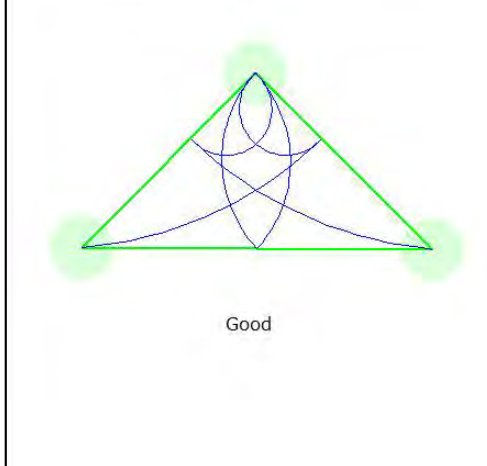
Equilateral Placement Border 	<p>Pattern 1</p>  <p>Good</p>	<p>Pattern 2</p>  <p>Bad</p>
'Best Fit' Placement Border 	 <p>Bad</p>	 <p>Good</p>

Some designs need to be placed using the equilateral/ 60° triangle, look at the angle of your design and try different placements to find the right fit and placement.

Triangle Block Power Placement continued. . .

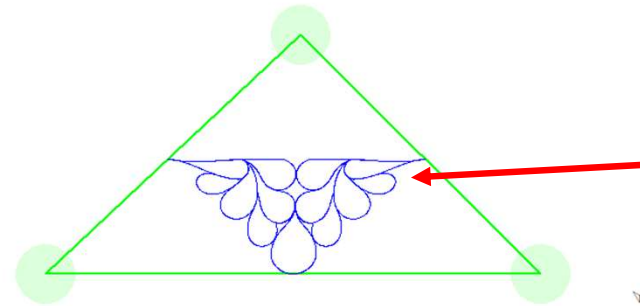
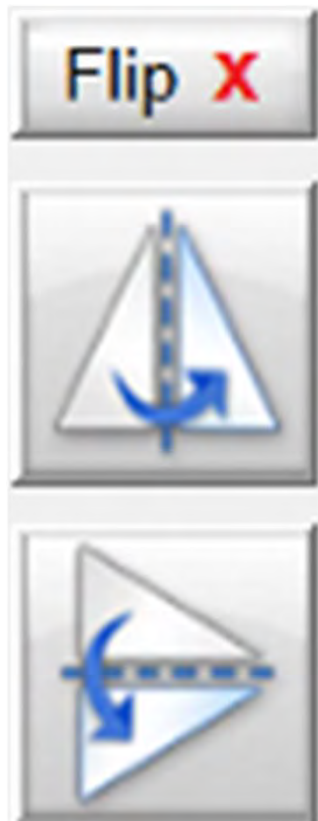

Flip, flips the design not the block.

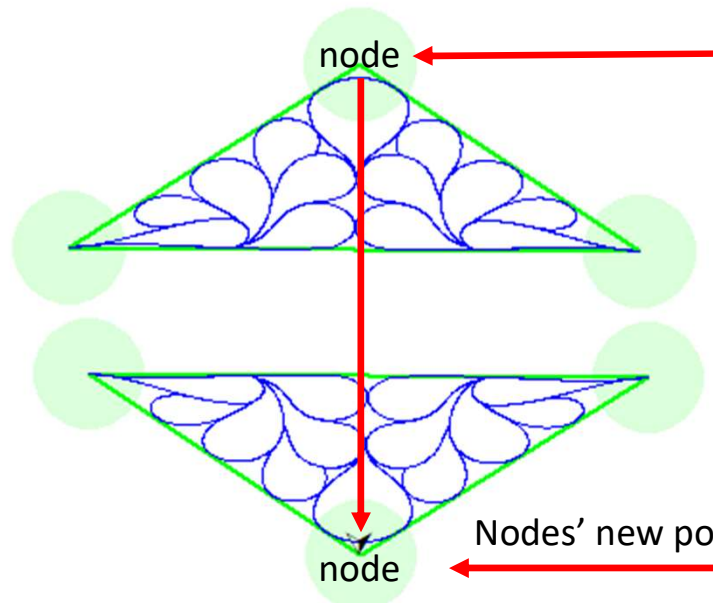

to flip the block and the design, use the placement nodes, take the upper node and move it down below as illustrated.

Nodes' new position

Triangle Block Power Placement continued. . .

“Margin” is the space between your quilting pattern/design and the edge of the seam.

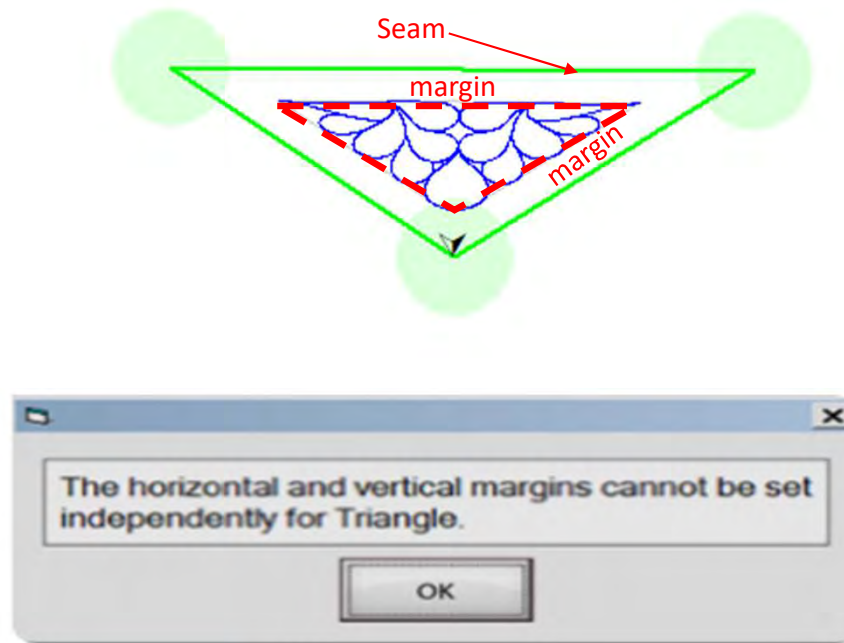
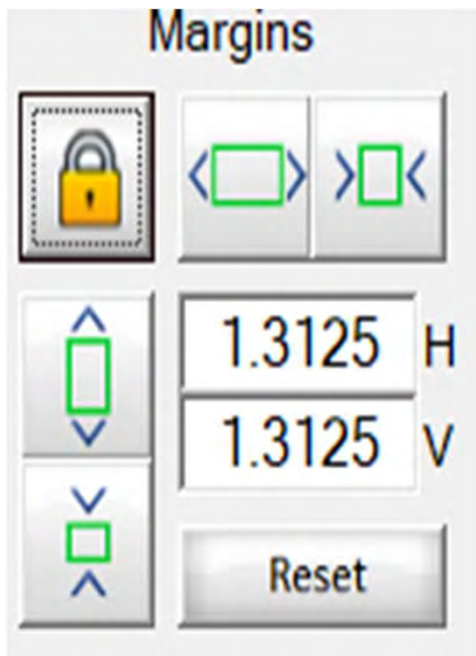

Margins are locked in triangle block placement. Decreasing the margin will decrease the size of the block proportionally.

On Point Power Placement

Pattern Placement

Select Pattern

Fit +

100%

Help Plug-ins

“On Point” placement sets a design with the corners positioned up or down
“On Point” helping create visual interest on your quilt.



Toolbox

All Triangle On Point Cube Side

Reset

Show Pattern Size

Show Placement Nodes

Stretch Fit

Flip X

Margins

Rotate 0

Reverse 0°

1° 5°

45° 15°

Reset

Pattern

Ditch

Markings

Quilt

On Point Power Placement continued. . .

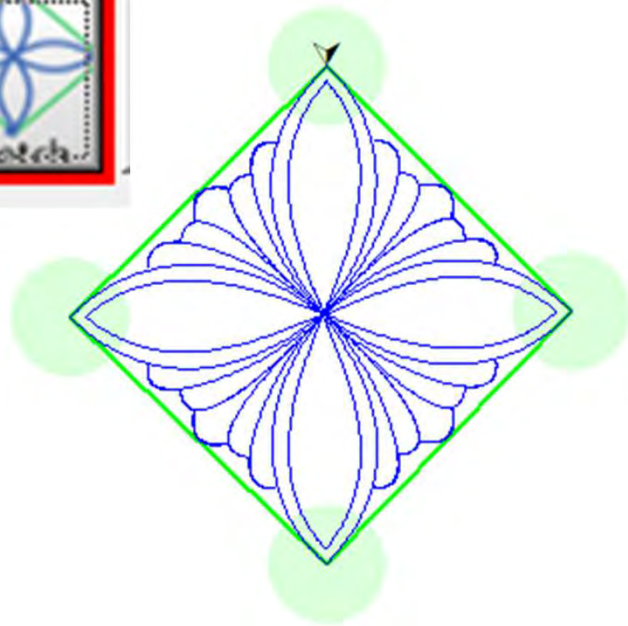

“Stretch”, stretches your design to the edge of your block. Stretch will stretch the design and not keep it proportional.

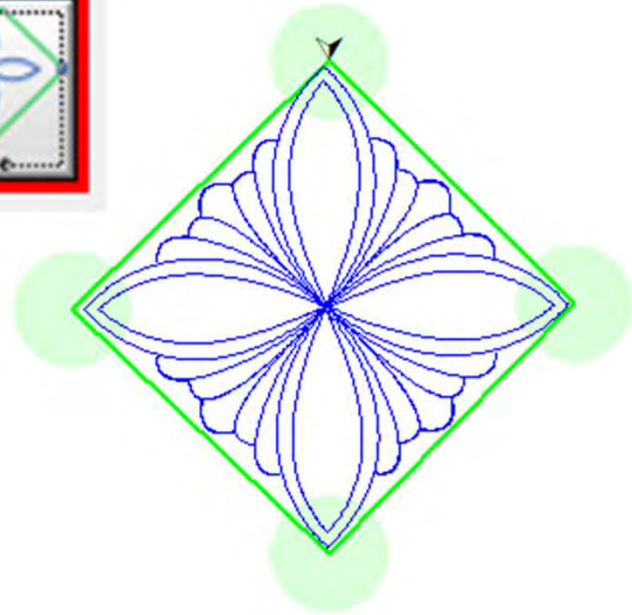

“Fit”, fits your design within the parameters of your block without stretching it, it keeps it proportional.

On Point Power Placement continued . . .

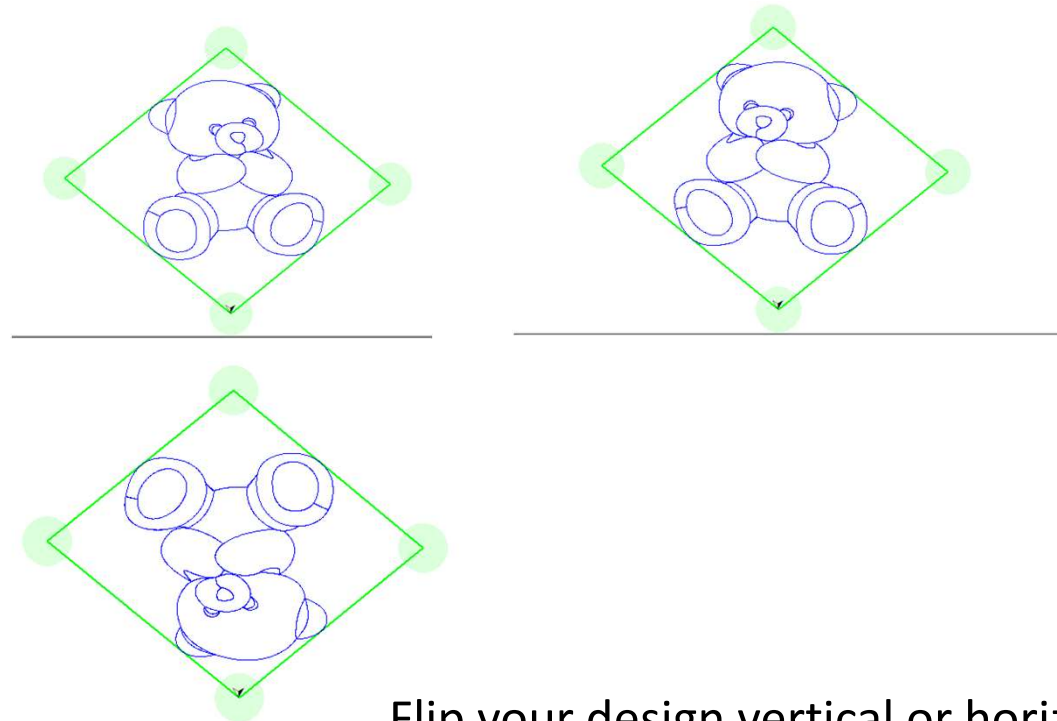

Flip your design vertical or horizontal. The flip function allows you changes the position of your design with the touch of the button.

On Point Power Placement continued. . .

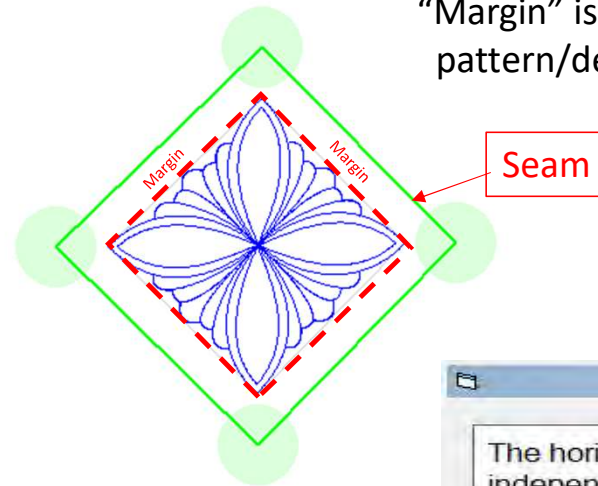
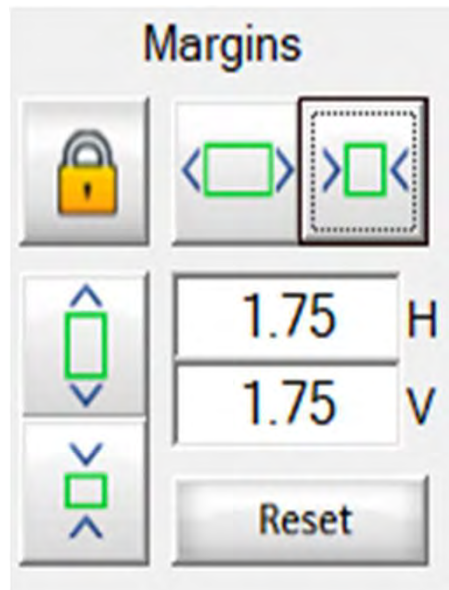

“Margin” is the space between your quilting pattern/design and the edge of the seam.

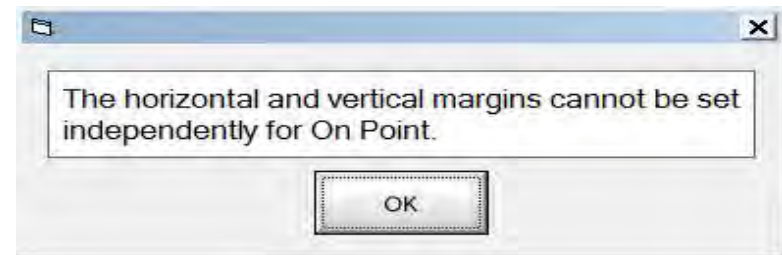

Margins are locked in “On Point” block placement. Decreasing the margin will decrease the size of the block proportionally. Increase is not allowed because the margins are locked.

On Point Power Placement continued. . .

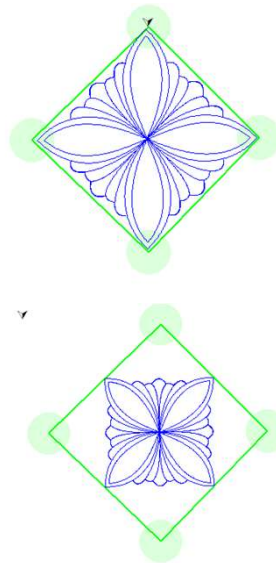
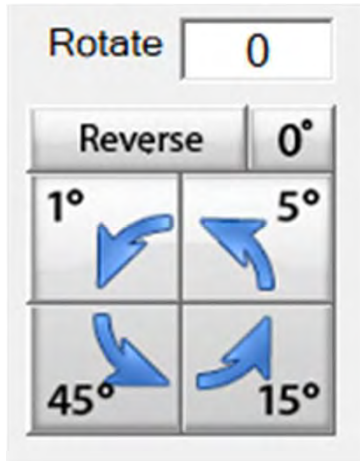

Rotate will rotate your design not the block if you have a design that is "On Point" it will rotate and become a square design.

A square design can be rotated to become an "On Point" design, use the 45° rotate to rotate 'On Point.'

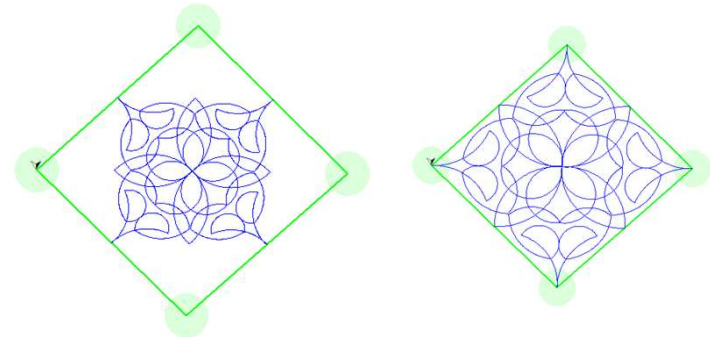
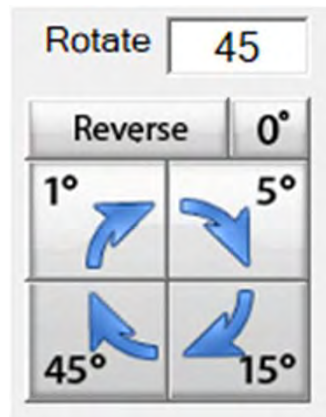

Cube Power Placement

Pattern Placement

Select Pattern

Fit 100%

Help Plug-ins

Cube placement helps add another element of dimension/3D on your quilt.

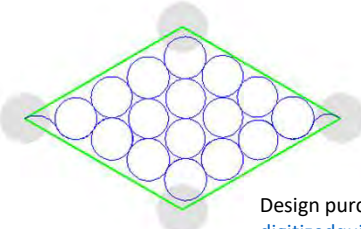

Design purchased from digitizedquiltingpatterns.com/

Toolbox

All On Point Cube Side

Reset

Show Pattern Size

Show Placement Nodes

Flip X

Margins

Rotate 0

Reverse 0°

1° 5°

45° 15°

Reset

Pattern

Ditch

Markings

Quilt

Cube Power Placement continued. . .

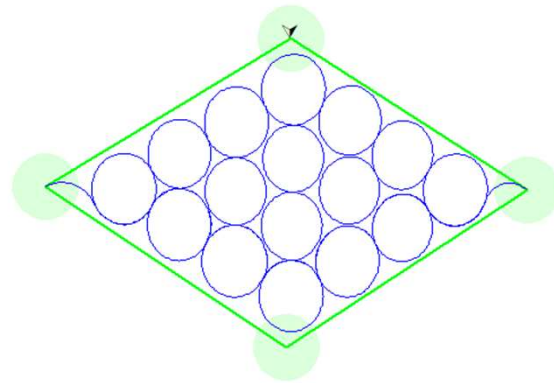

Design purchased from
digitizedquiltingpatterns.com/

“Stretch”, stretches your design to the edge of your block. Stretch will stretch the design and not keep it proportional.

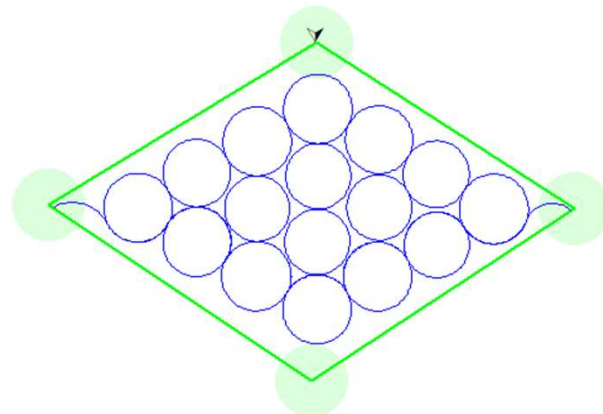

Design purchased from
digitizedquiltingpatterns.com/

“Fit”, fits your design within the parameters of your block without stretching it, it keeps it proportional.

Cube Power Placement continued. . .

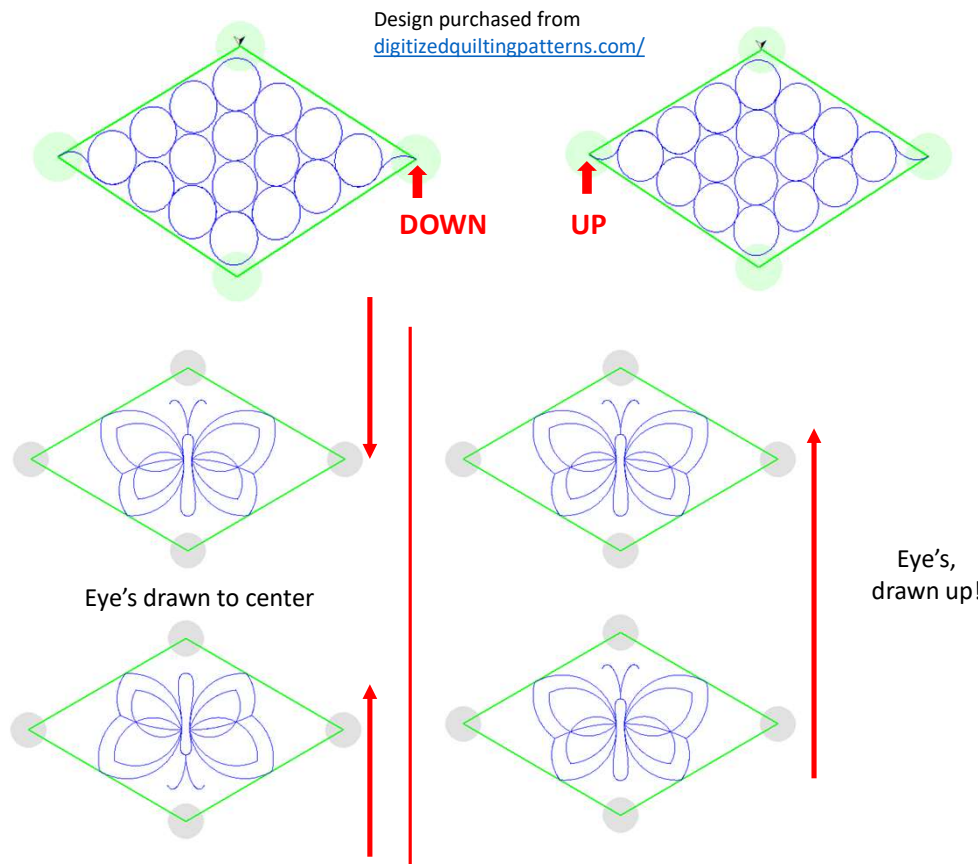

Using the vertical flip can change how a design will sew, it can change your how your design looks slightly, altering how your eyes see the design on your quilt block.

Flip your design on the bottom of your block/quilt, your admirer's eyes are drawn towards the center

Cube Power Placement continued. . .



Rotate your pattern/design 1° , 5° , 15° or 45° using the rotate to set your pattern/design to the desired angle. Reverse rotate will reverse direction.

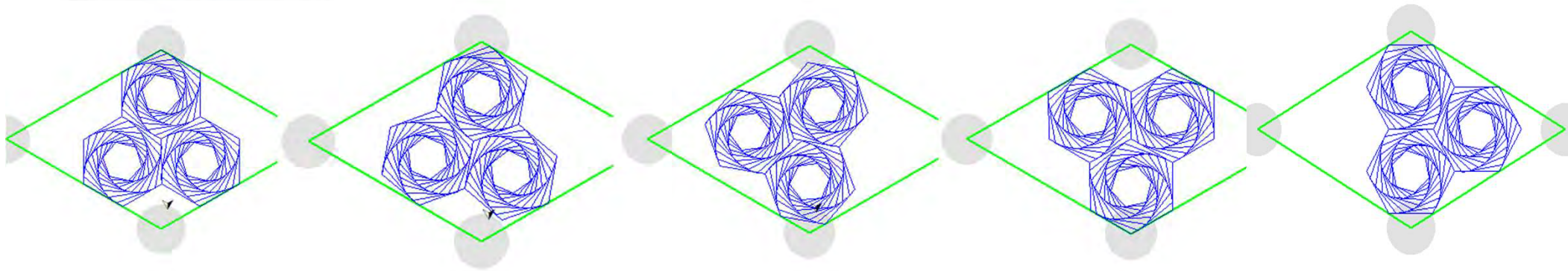

Cube Power Placement continued. . .

“Margin” is the space between your quilting pattern/design and the edge of the seam.

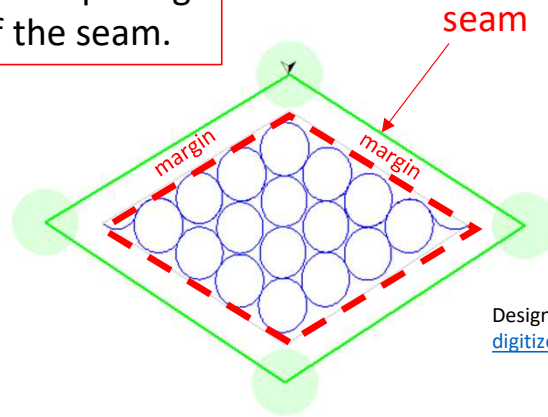

Design purchased from digitizedquiltingpatterns.com/

Margins are locked in “Cube Point” block placement. Decreasing the margin will decrease the size of the block proportionally. Increase is not allowed because the margins are locked.

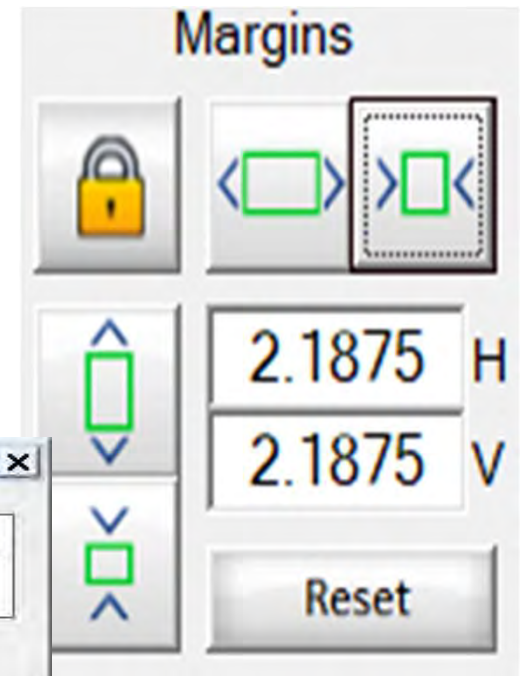
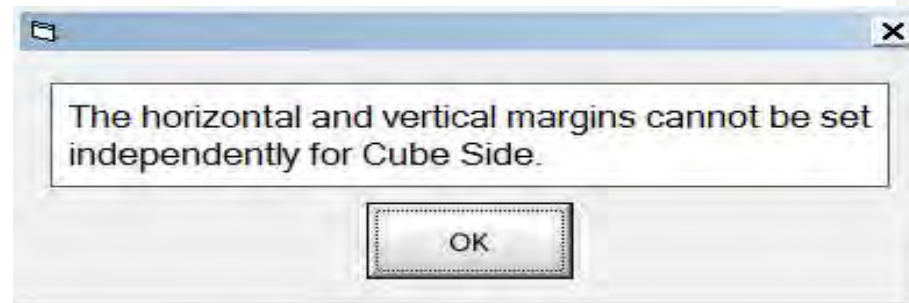

QuiltMotion Quick Start Guide

How To Place and Sew a Design

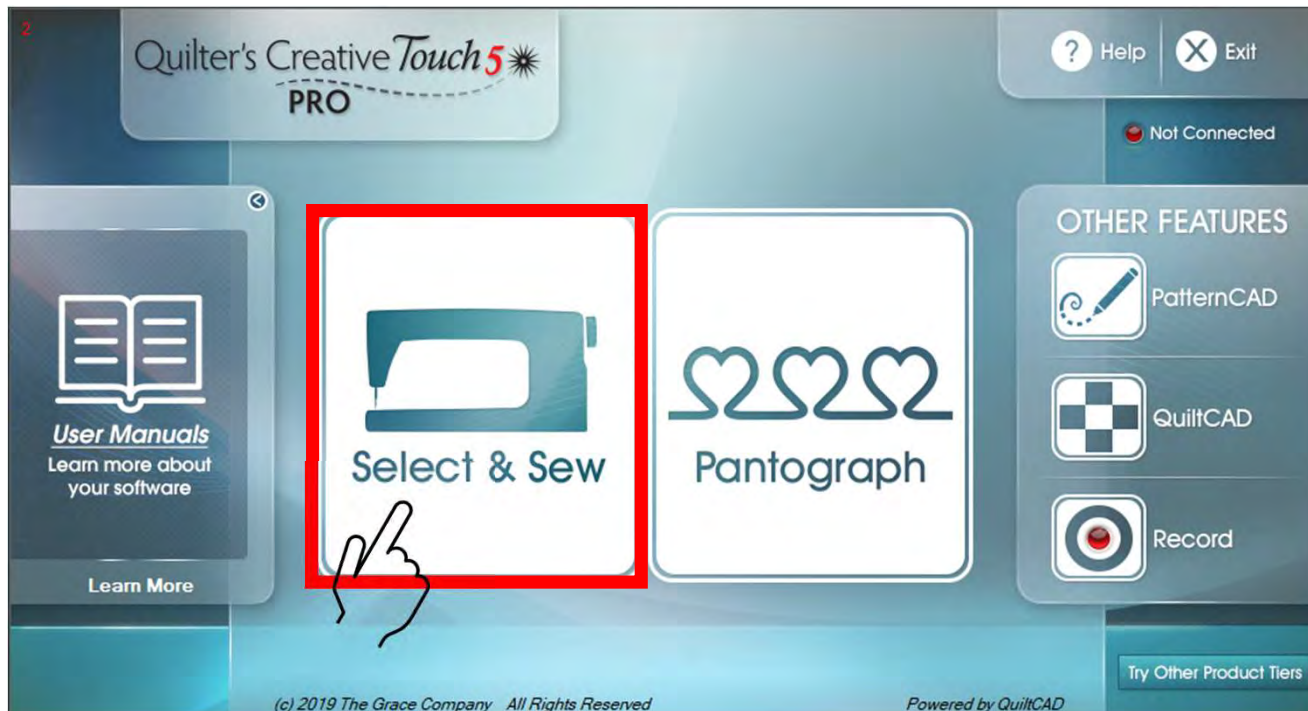

“Click on” **“Select & Sew”** to set your “Safe Area”
and open the “Power Placement” screen.

Place and Sew a Design continued. . .

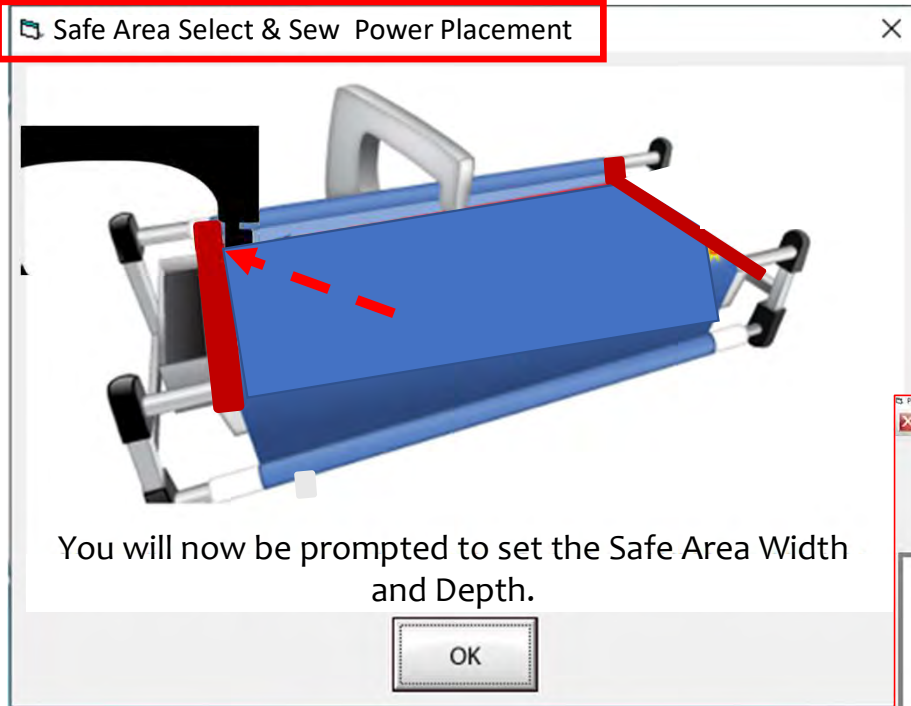

The “Safe Area” is your “quiltable,” quilting area on your quilt top. Move your machine to the “TOP LEFT of your Quilt Top corner (edge) and tap on the screen in the “Click to Set the Safe Area.” You have now set your “Safe Area” WIDTH. **“STOP”** Read next page.

Select & Sew Power Placement Depth (the Depth of your “Machine Throat” if you are putting the size in manually.

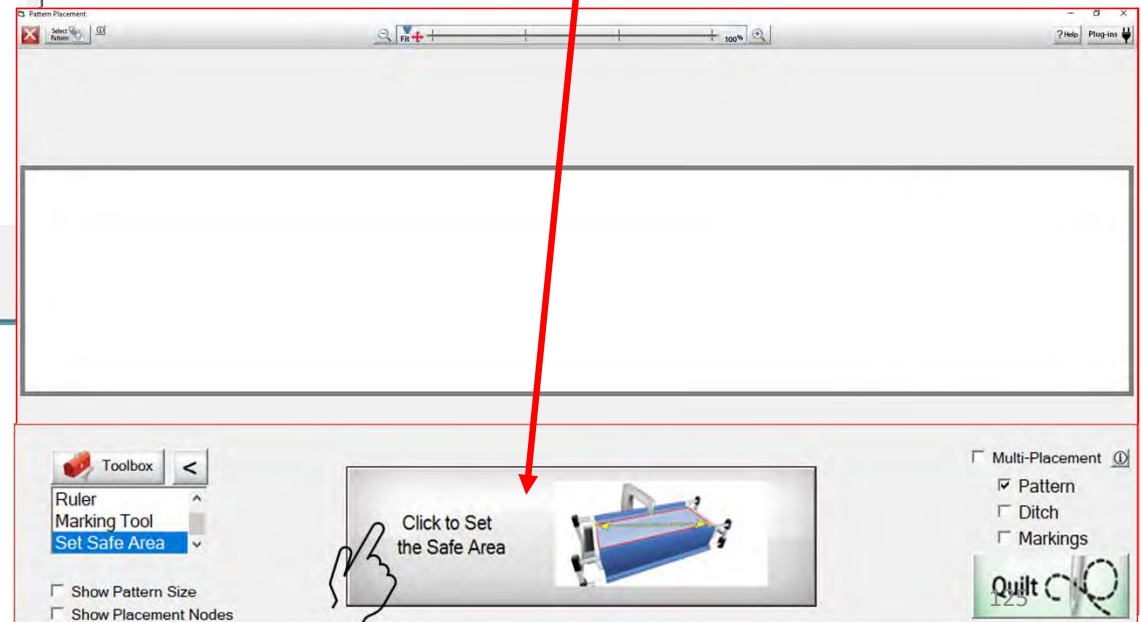

Place and Sew a Design continued. . .

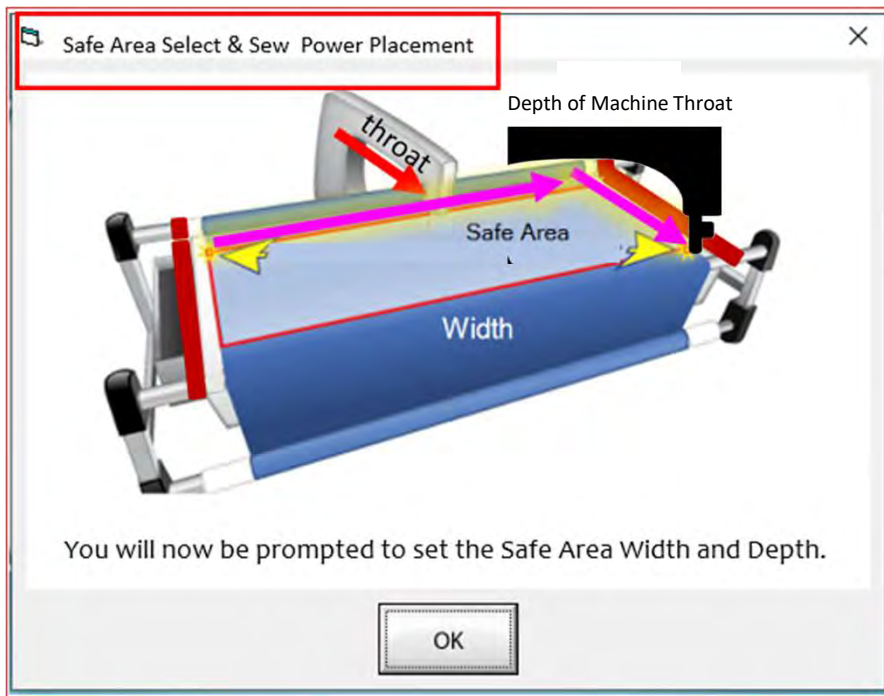

***Note:** Select & Sew Power Placement Depth (the Depth of your “Machine Throat” if you are putting the size in manually.

“Safe Area” “DEPTH” is your “quiltable,” quilting area determined by the arm (throat length) of your machine. Move your machine the width of the quilt top to the right top edge, then move the machine as far forward as you can towards the front of the frame as far forward as the machine will extend, keeping it on the right edge of your quilt to the “BOTTOM RIGHT” of your Quilt Top (edge) and tap on the screen.



Place and Sew a Design continued. . .

This is your “Read Pattern” screen, here you can choose different designs such as:

- Pattern Design (Purchased Designs)
- Block Design
- Continuous Line Design
- Triangle Design
- Border Sets Designs

Use the arrows on the right to scroll up and down through the design choices. To select a design, tap on it, a blue box will show that it has been selected. Now click on “Open” to open your “Pattern Placement” screen.

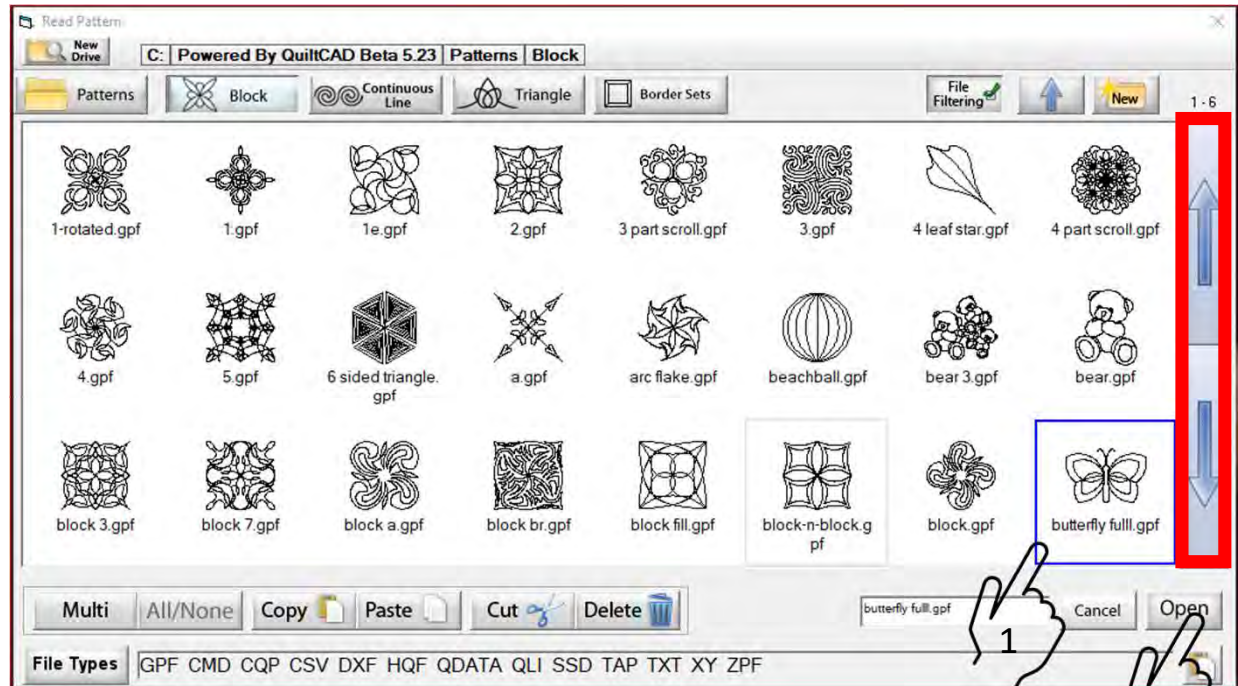

Place and Sew a Design continued. . .

Find the “Placements” using the arrows to the right find “Block” with “Block” placement you will have two placement nodes (gray dots around design). One is at the top left of the design and one at the bottom right.

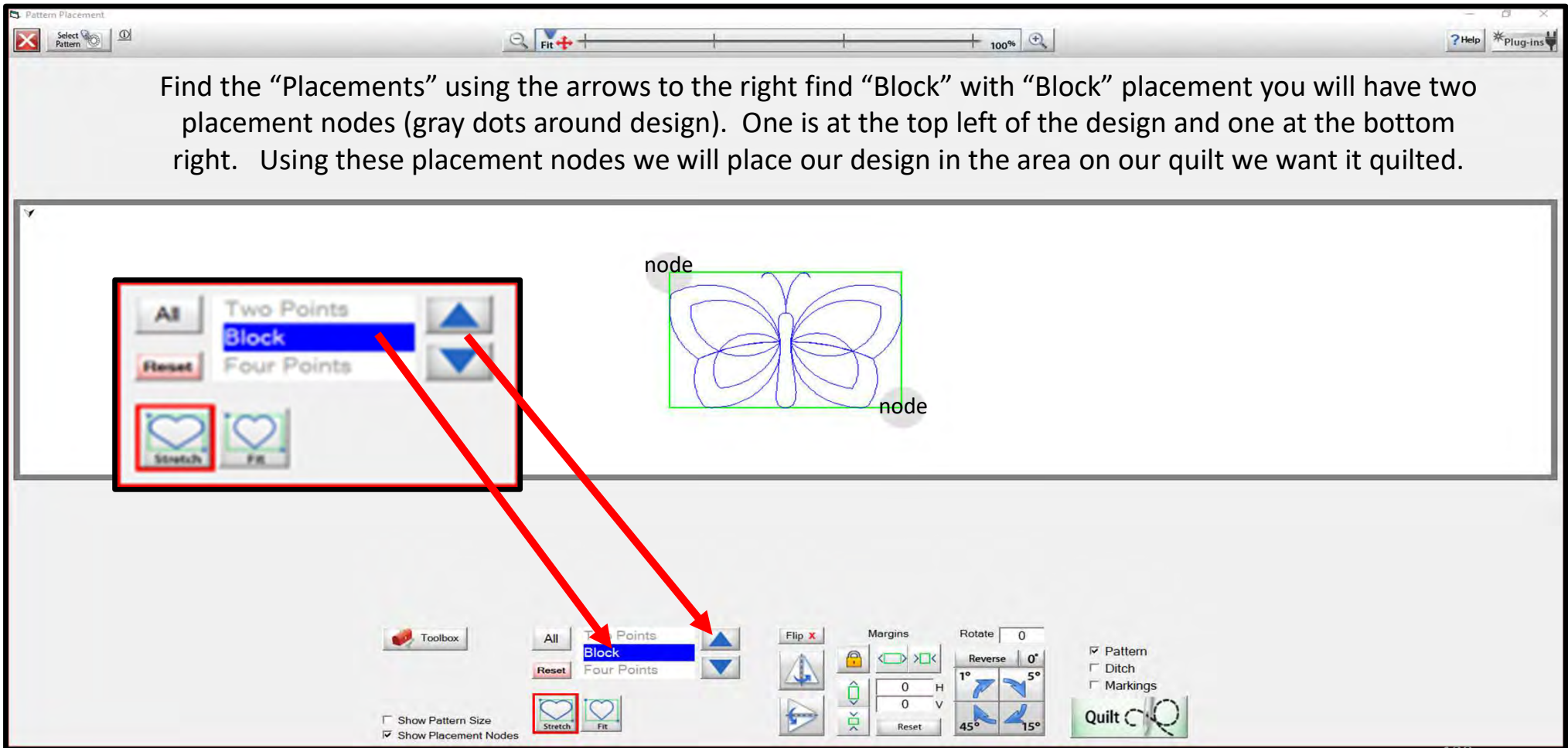

Place and Sew a Design continued. . .

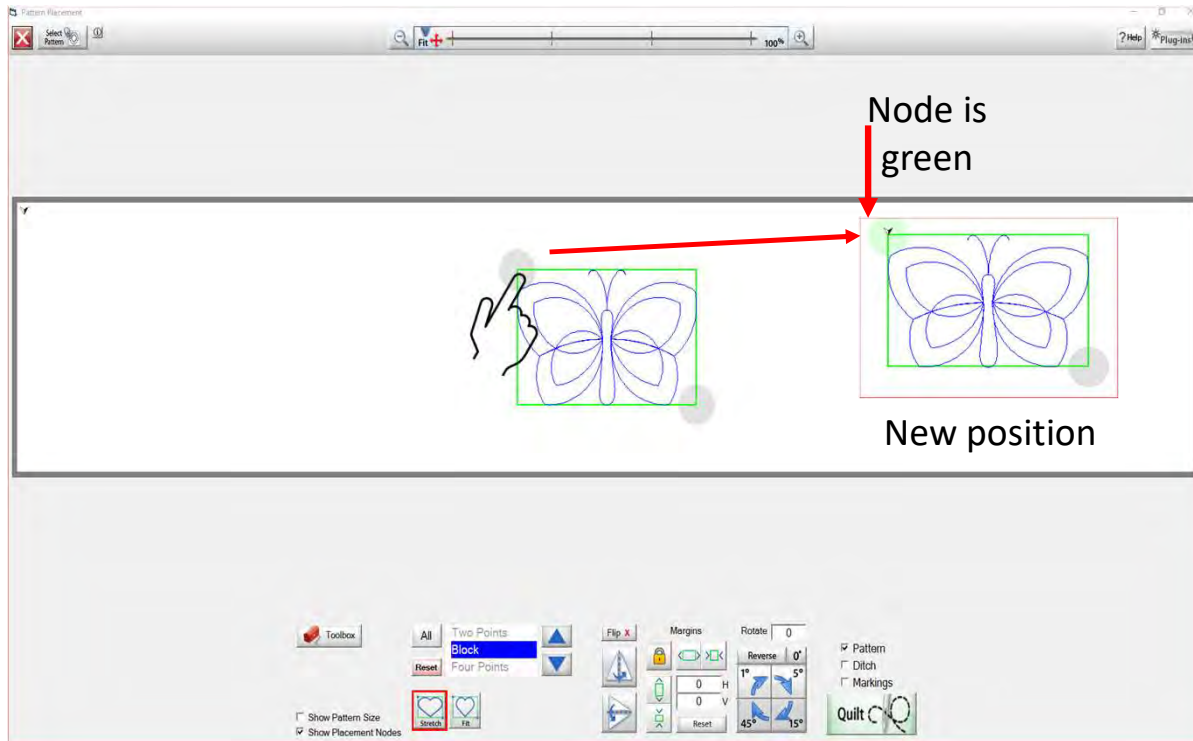

Move your sewing machine to the first placement point on your quilt. I have chosen the top left corner of my block on my quilt. Tap on the top left placement node of your design, your design will now move on the tablet screen to the position as to where you moved your machine on your quilt.

Place and Sew a Design continued. . .

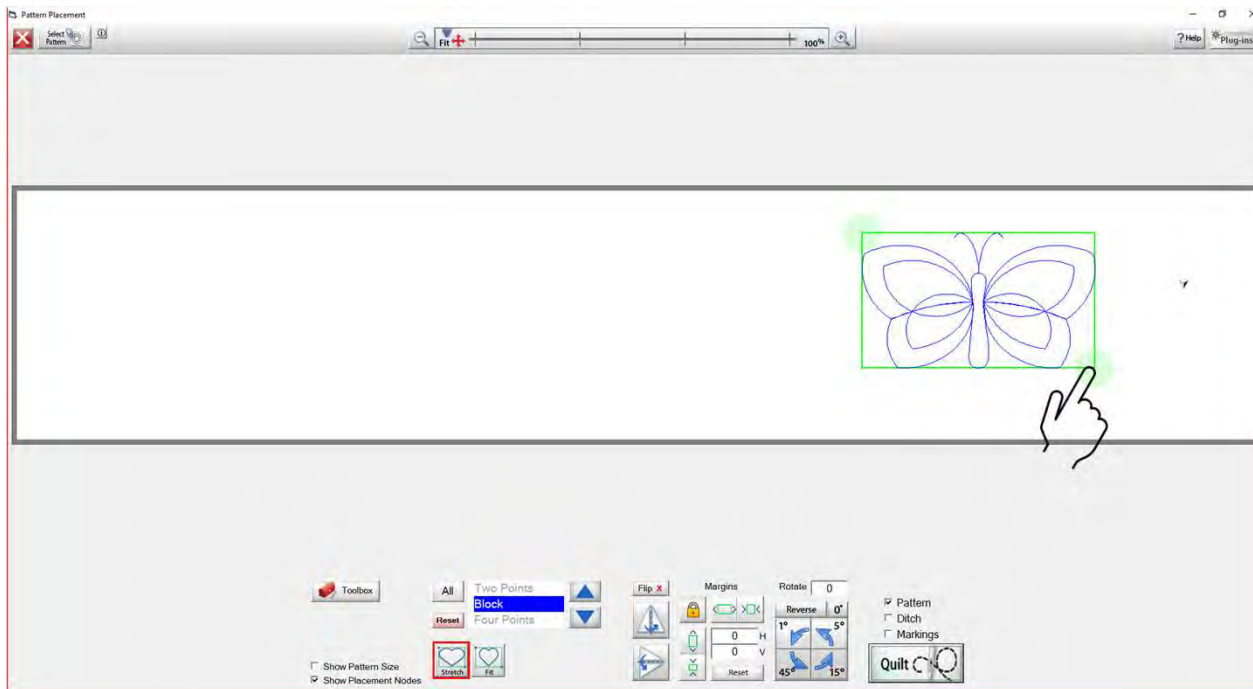

Move your machine to your 2nd placement, I have chosen the bottom right corner of my block on my quilt. Tap on your bottom right node and once you have placed it the node will turn from gray to green.

Place and Sew a Design continued. . .

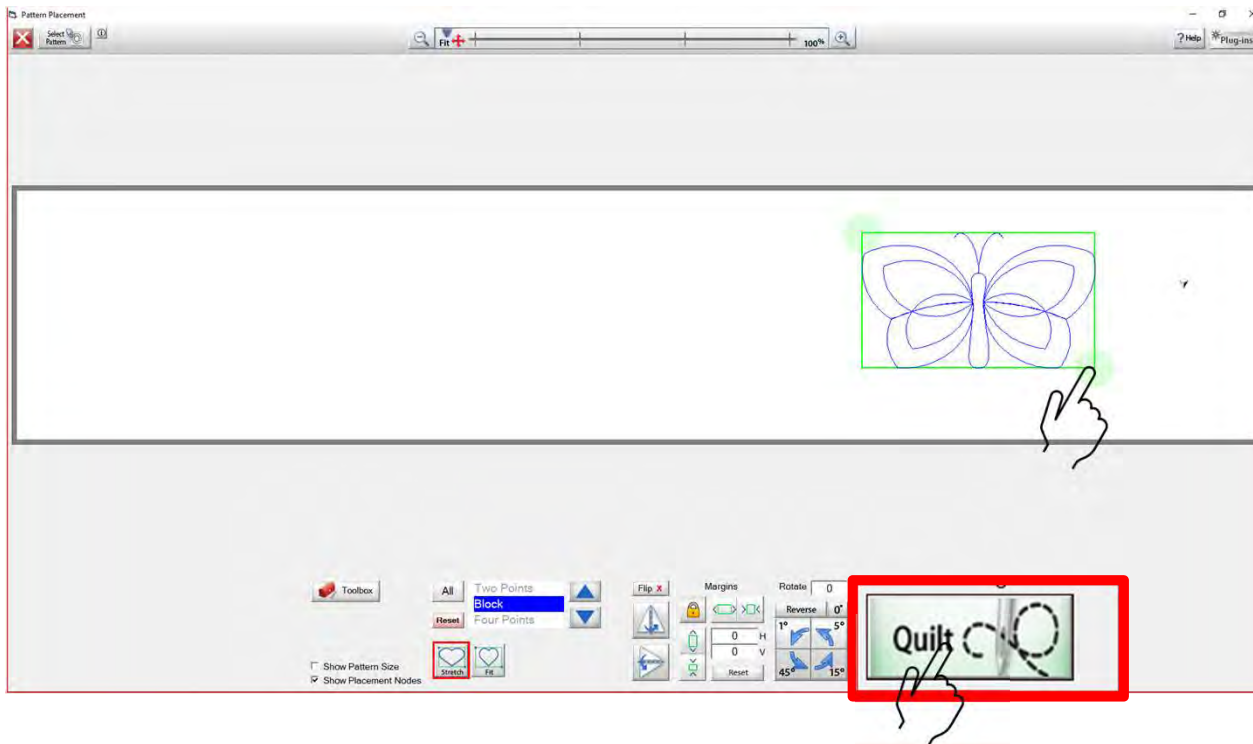

Once you have placed your design, we can click on “Quilt,” this will take us to our “Quilting Interface” screen.

Place and Sew a Design continued. . .

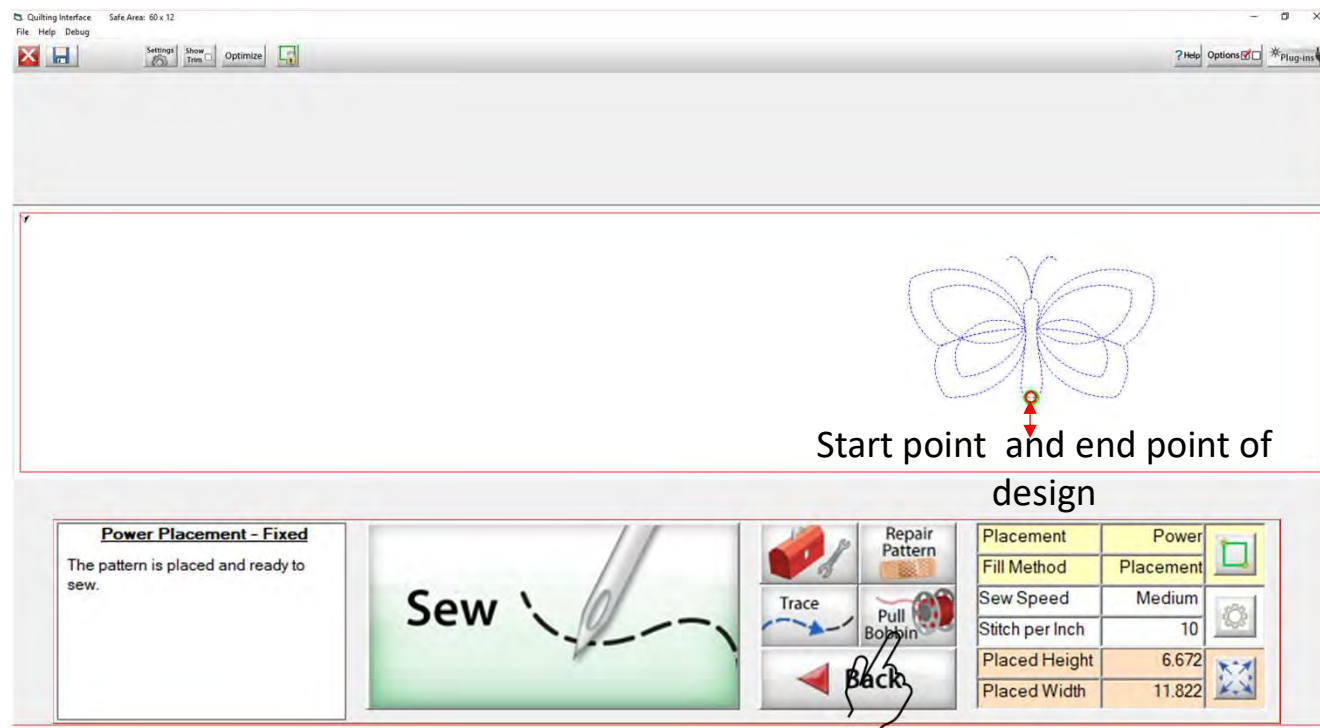

Click on “Pull Bobbin” your machine will engage with the automation, slightly moving just a bit a prompt will show on your screen to make sure your needle is in the up position. Click “OK” after making sure the needle is up, your machine will move to where your design will start quilting on your quilt block.

Place and Sew a Design continued. . .

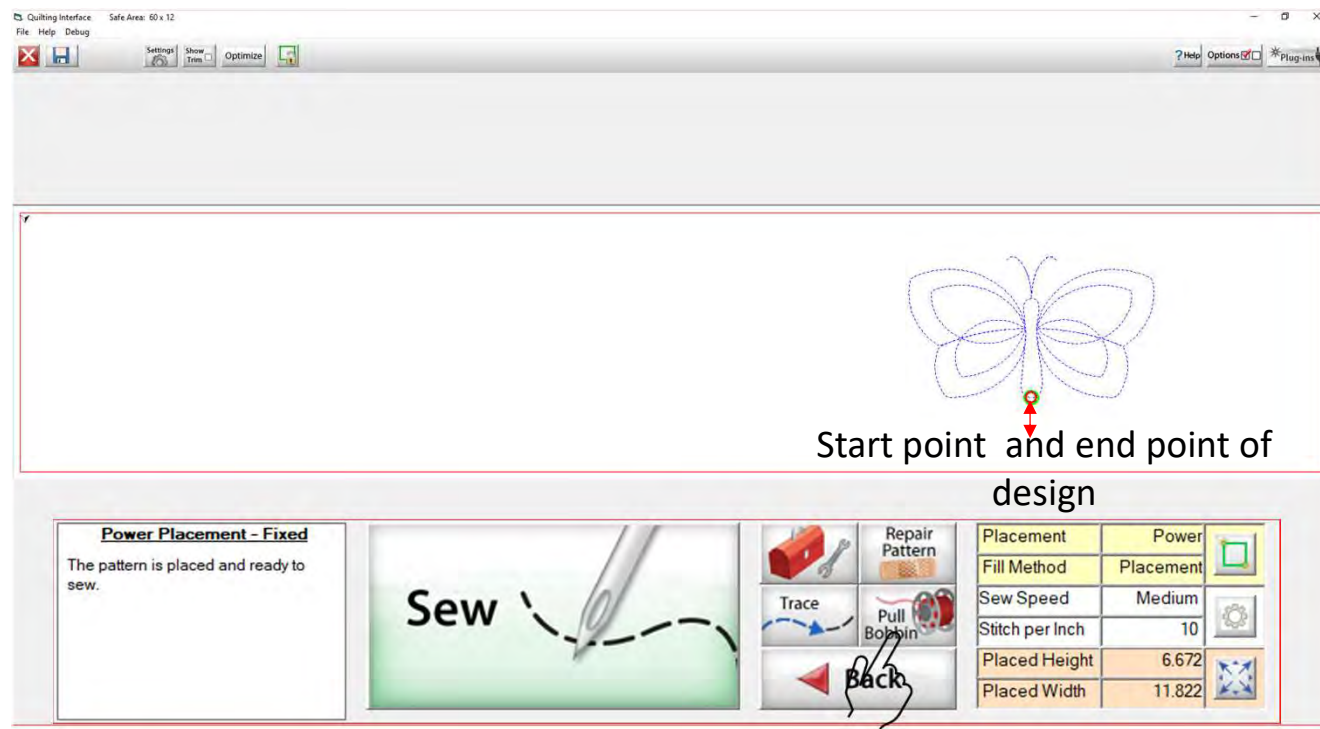

Once the machine has moved to where it will start sewing, your needle will automatically go down into the fabric to catch your bobbin thread. After it has finished going down into your fabric you will see the prompt again asking if your needle is up. Click "OK."

Place and Sew a Design continued. . .

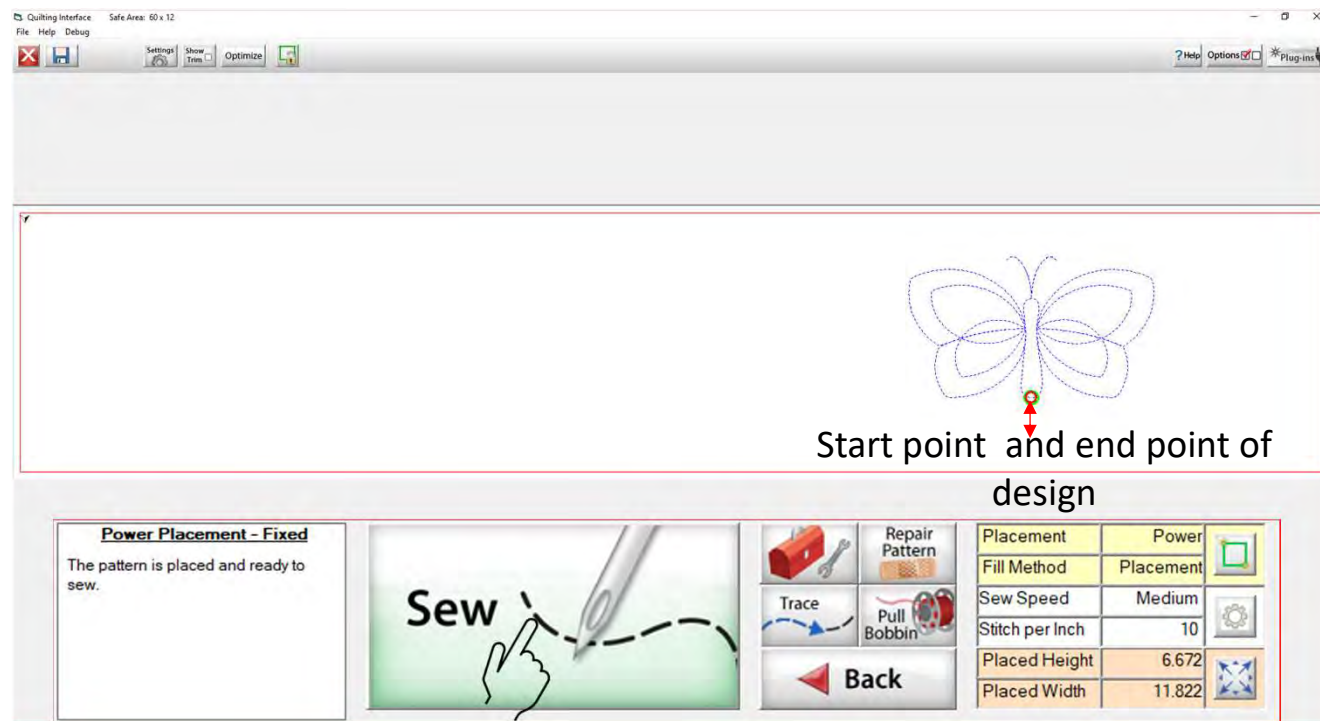

The sewing machine will move away from the start point pulling your bobbin thread up to the top of your quilt. Once the bobbin thread has been pulled click on "SEW." The sewing machine will move back to your start point of your design and do a stitch tie off and start sewing your design on to your quilt block.

Place and Sew a Design continued. . .

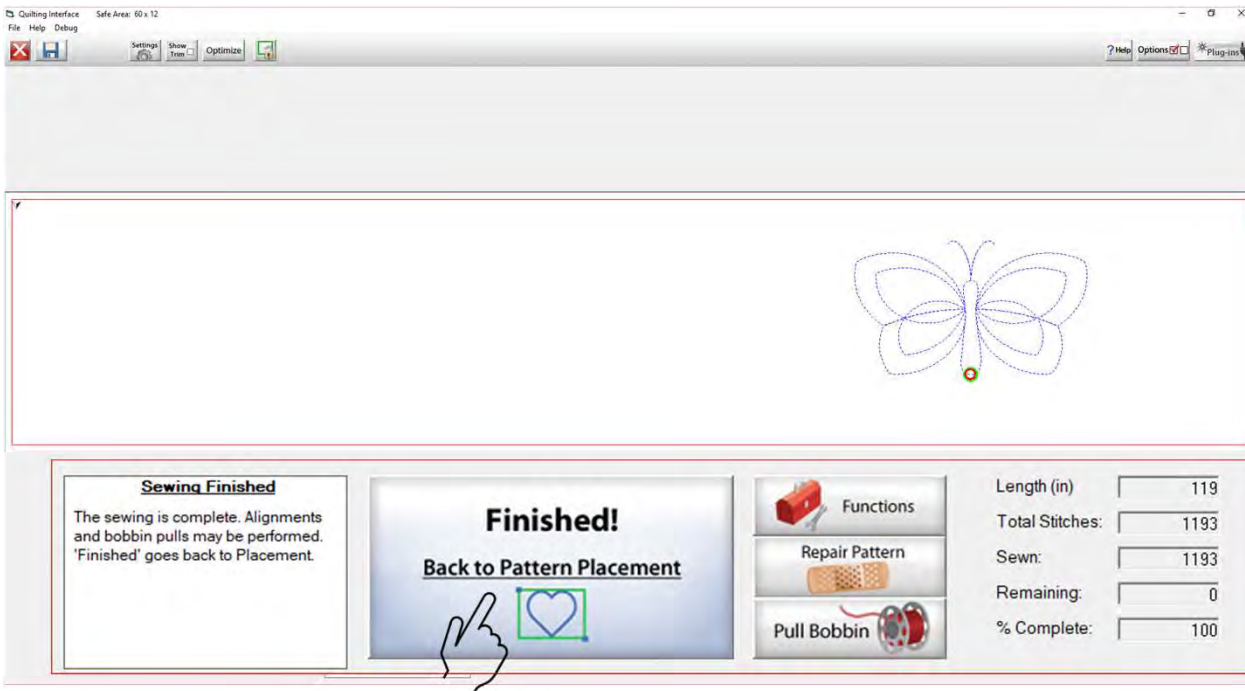

Click on “Finished!” pull your machine to the side of your design, to give some length to your bobbin thread. Move your machine back to where you ended quilting and click on your needle down button or tap on your needle down on your machine screen. Bring your needle back up and with it your bobbin thread. Cut both threads and proceed on to place your next design.

Power Placement continued. . . Quilting Interface Screen

Once you have decided your design and the placement method it is time to quilt the design onto your quilt. Click on “Quilt” located at the bottom right of the “Power Placement Screen.” The “Quilting Interface” screen will pop open. Let me walk you through the features and how to use them on the “Quilting Interface” screen.

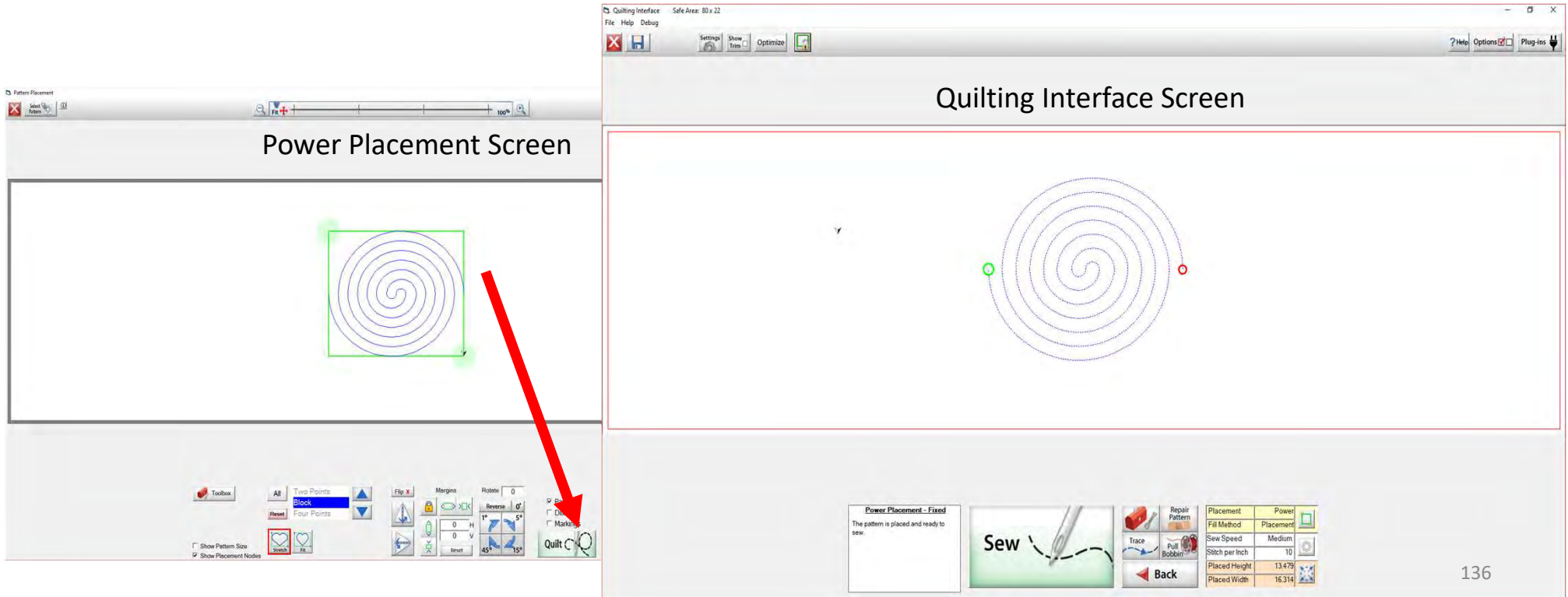

Power Placement continued. . . Quilting Interface Screen

The "Quilting Interface" screen is where you will sew your design onto your quilt. Beginning from the top left of the screen it show you what screen you are in (Quilting Interface). It also show you your "Safe Area" 80" is the "Width" and 22" is the "Depth." Right below starting with the red X are the option buttons.

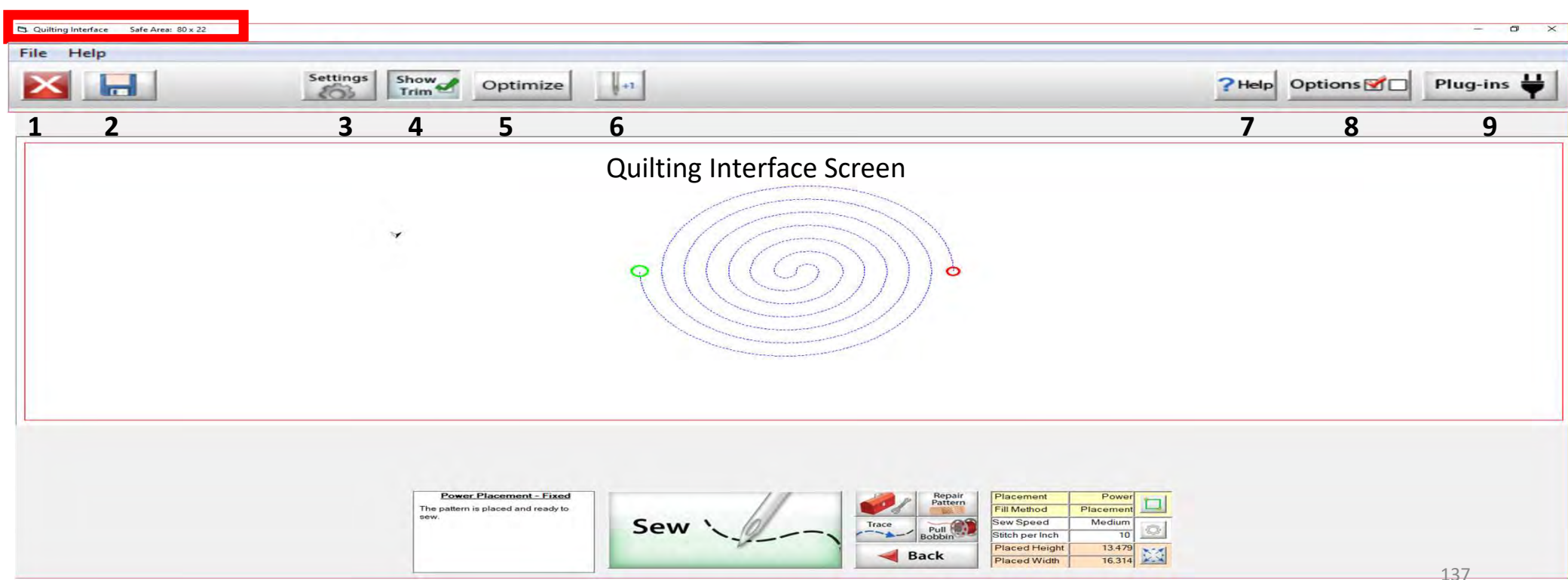

Power Placement continued. . . Quilting Interface Screen

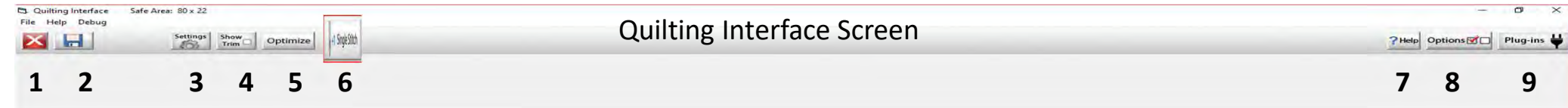

1. EXIT the "Quilting Interface" screen back to "Pattern Placement" screen.



2. SAVES your pattern/design.



3. SETTINGS change the settings such as stitches per inch, tie off, and sewing speed.



4. SHOW TRIM allows you to see your trims lines.

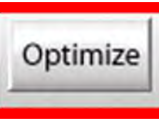

5. OPTIMIZE allows you to connect sections of your pantograph design to make it a single design with no breaks.



6. Single Stitch allows you to make a single stitch while connected to the automation.



7. HELP allows you to access the help files and get more detailed information about QuiltMotion/QCT software.

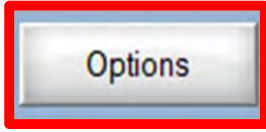

8. OPTIONS access the "Preferences Menu."



9. PLUG-INS access the "Marking Tool" to help you place your design with precision and accuracy. If you have the Gold Card it will give you access some advanced features.

Power Placement continued. . . Quilting Interface Screen

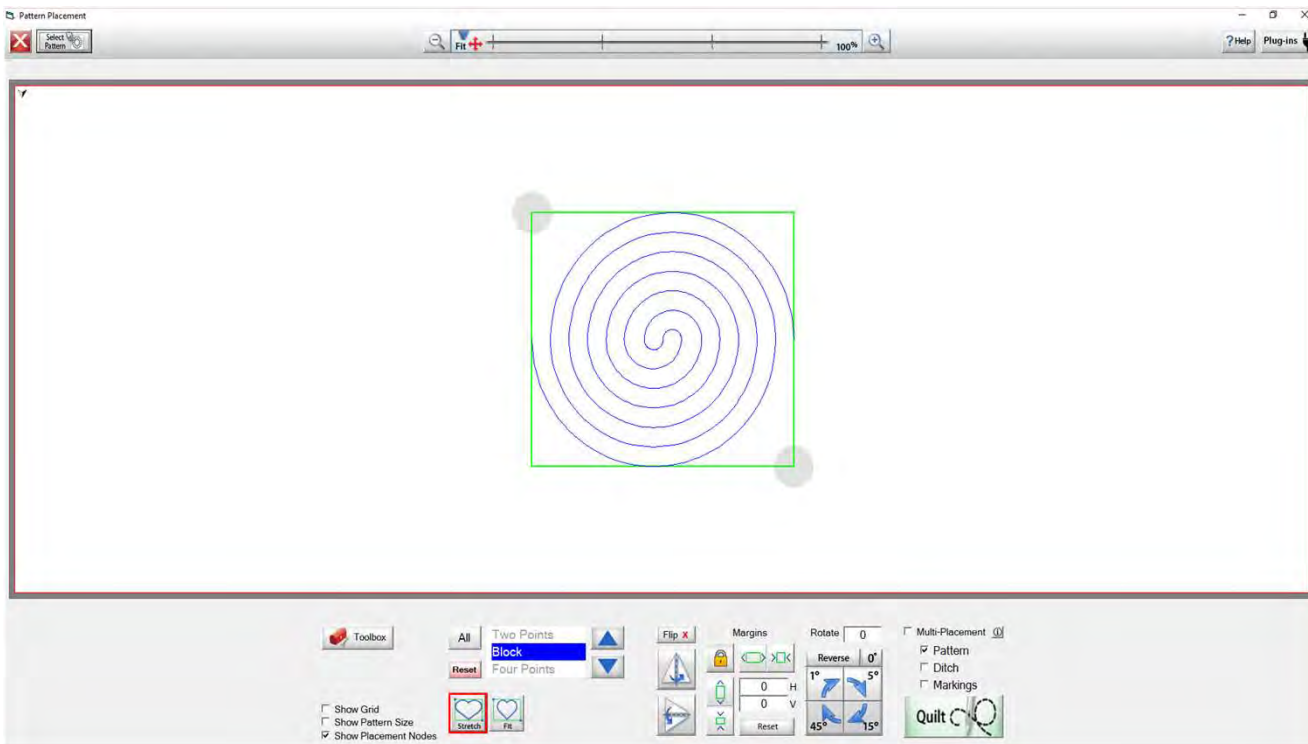
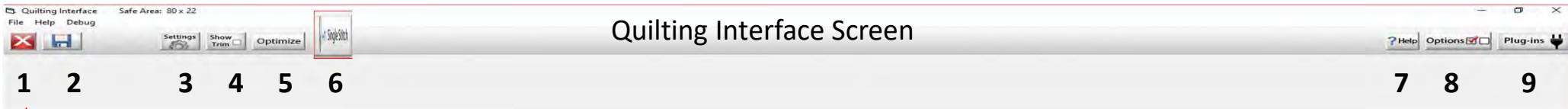

1. Click on "EXIT" to leave the "Quilting Interface" screen and return to the "Pattern Placement" screen.

Power Placement continued. . . Quilting Interface Screen



2

Save your design/pattern, if you are using your design for a border or sashing or another block throughout your quilt SAVE it so you don't have to resize every time you are placing the design. 1. Click "SAVE."

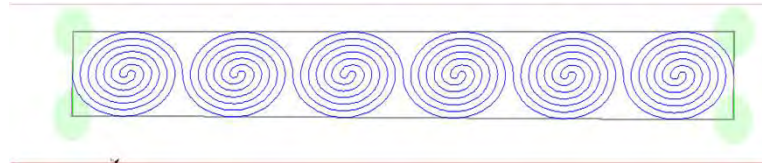

2. "Click" on the "Save" icon. The "Read Pattern" screen will pop open. Decide which folder you would like since it is a pantograph design, I have chosen "Continuous Line". 3. Click inside the open window. The "Touch Keyboard" will pop open. Type the chosen name for you design, then click on "Enter," on the keyboard. 4. "Click" on Save. Your design is now saved in "Continuous Line" folder for future use. Use the arrows on the side to scroll and find your saved design. They are saved alphabetically.

3

4

Power Placement continued. . . Quilting Interface Screen



If you would like to open a new folder and save your pantograph design “click” on “New.” “Create New Folder” window will pop open asking you to “Enter the new folder name.” “Click” in the window and your “Touch Keyboard” will pop open. Enter the new folders name and “Click” OK. You now have a saved folder to save your design into. When you save your design choose your new folder as the place to save it too, rather than one of the existing folders.

The image displays a sequence of screenshots from the QuiltCAD software interface, illustrating the process of creating a new folder to save a design. The screenshots are overlaid and connected by red arrows, showing the following steps:

- The "Read Pattern" window is shown with the "New" button highlighted in the top toolbar.
- The "Create New Folder" dialog box is shown, prompting the user to "Enter the new folder name". The text "spiral quilt test pant" is entered into the input field.
- The "Touch Keyboard" is shown below the dialog box, indicating that the user is ready to input the folder name.
- The "Save Pattern" window is shown with the "New" button highlighted in the top toolbar.
- The "Save Pattern" window is shown with the "spiral quilt test pant" design selected in the pattern list.
- The "Save Pattern" window is shown with the "File Name" field highlighted in red, indicating that the user is ready to save the design into the newly created folder.

Power Placement continued. . . Quilting Interface Screen



3. SETTINGS Change your sewing machine and QuiltMotion settings such as Stitches per inch, tie off, and sewing speed.

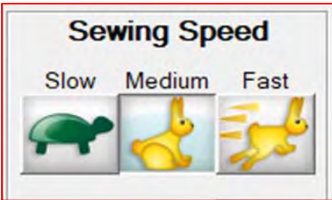

“Click” to set sewing/Automation speed to Slow, Medium or Fast



Use the (+) to increase or (-) to decrease the stitch length.

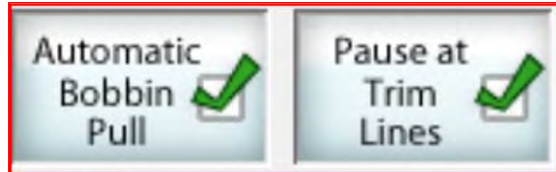

Checked will automatically prompt pull your bobbin and pause at a trim line.

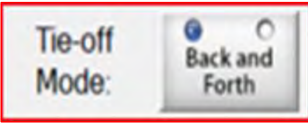
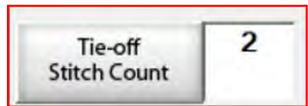

Tie-Off mode, ties a knot to keep stitches in place. Choose either a small micro stitch or back and forth and how many tie off stitches you want to secure your design beginning and end.

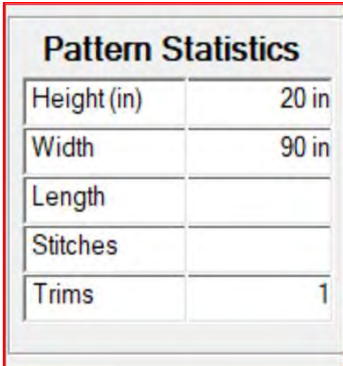

Pattern statistics shows you the height and width of your design and length you have quilted. It also counts your stitches as it is quilting and informs you to how many trims you have on your design.

Power Placement continued. . . Quilting Interface Screen



4. SHOW TRIM allows you to see your trims lines. When checked will show as a blue dot in the design. Trims lines indicate the design has ended and is not connected to the next section. The machine will stop at the trim line and ask if you want to “Move to the Next,” this leaves a thread to be cut which is the “Trim Line.”

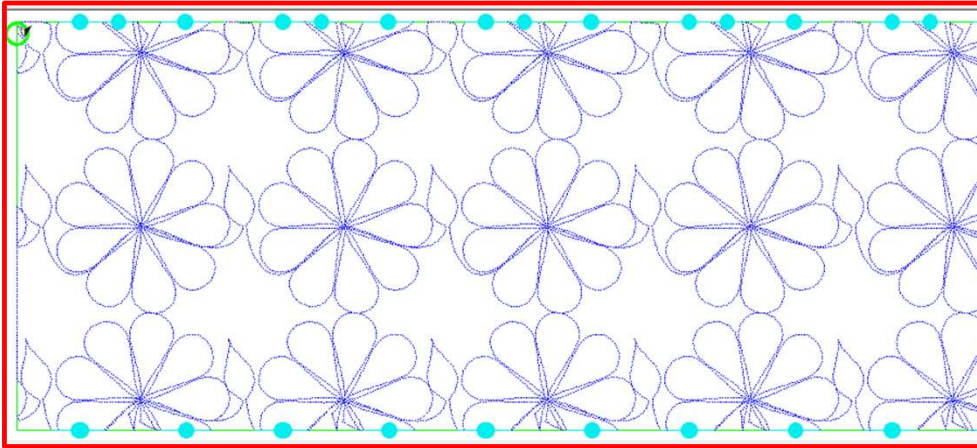

Notice all the trims (blue dots) in this design. This means that your machine will stop where each dot is located on the design.

To eliminate the trims you will need use the optimization screen which is what the next feature.

Optimize

Power Placement continued. . . Quilting Interface Screen

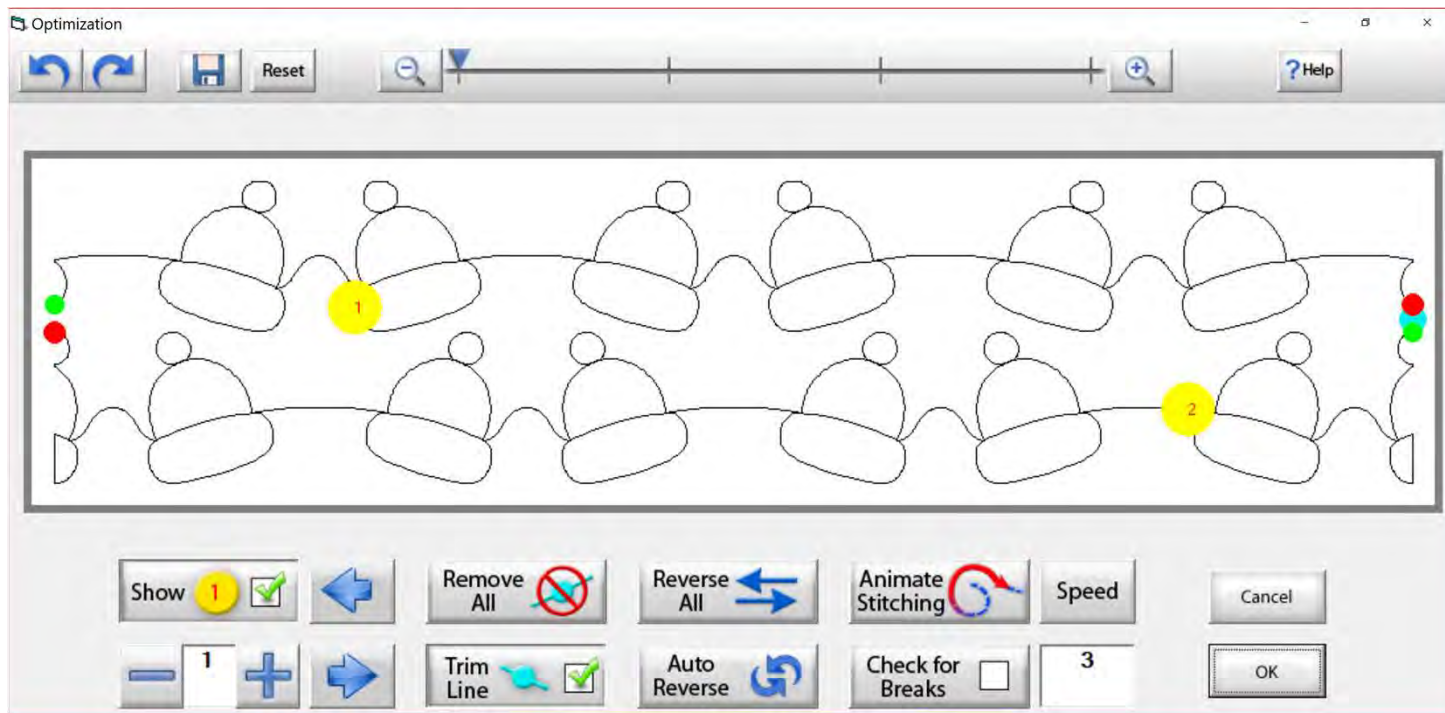

5. This is the “Optimization” screen allows you to make the design you are quilting sew smoothly without stopping. Let me take you through the process of using these tools to optimize your design.

Optimize

Power Placement continued. . . Quilting Interface Screen

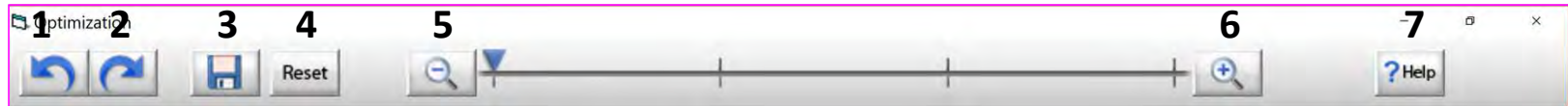

1. Undo-Undo last action on screen.
2. Redo-Reapply last undo.
3. Save-Save your pantograph design.
4. Reset-Resets pattern to its original state.
5. Zoom-in- Zooms in to make design larger.
6. Zoom-out- Zooms out to make it smaller.
7. Help-Opens this help file.

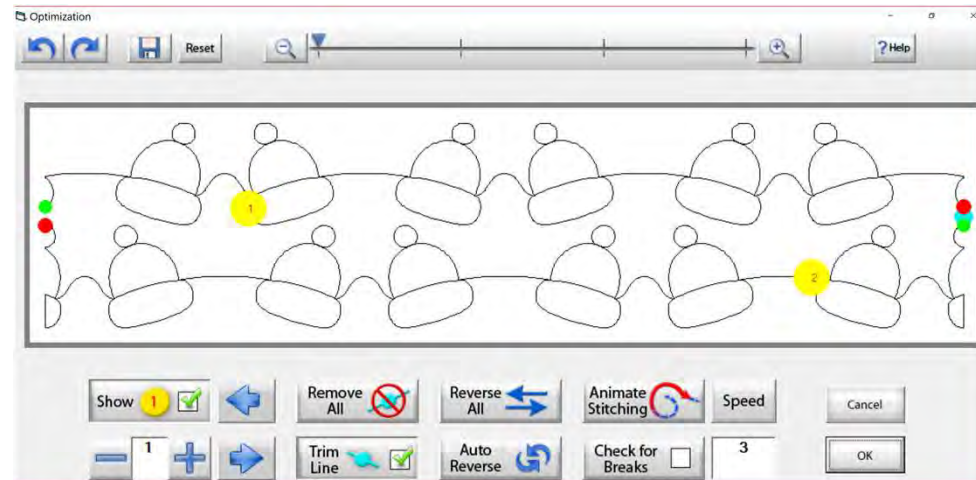

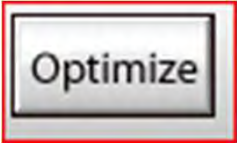

Power Placement continued. . . Quilting Interface Screen

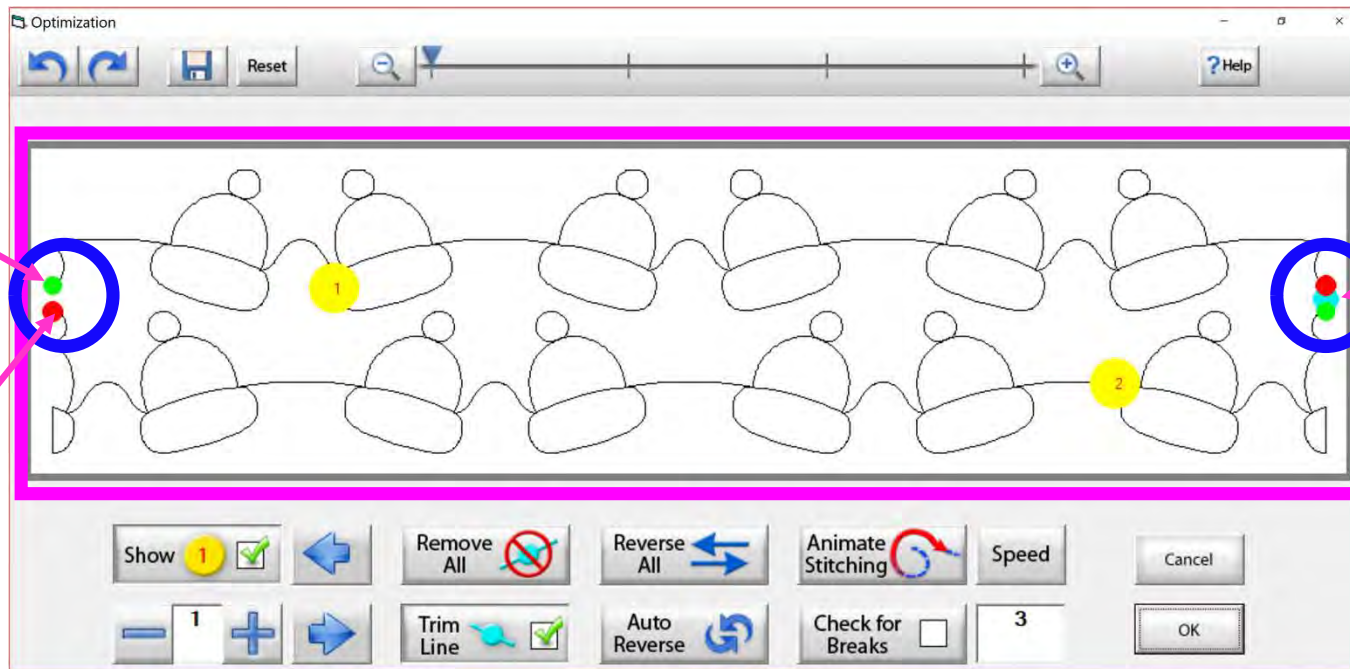

Start sewing green
Stop sewing Red

There is a trim line the blue dot. Indicates the designs has ended is not connected.

The optimization screen shows where your pantograph will start sewing (green dot) and where it will stop (red dot). It shows the (direction) the pantograph design will sew. The yellow dots show which section will sew first (1) and then (2), you will also see if there are trim lines. (A trim line is a section of thread at the end of the design.)

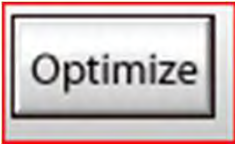

Power Placement continued. . . Quilting Interface Screen

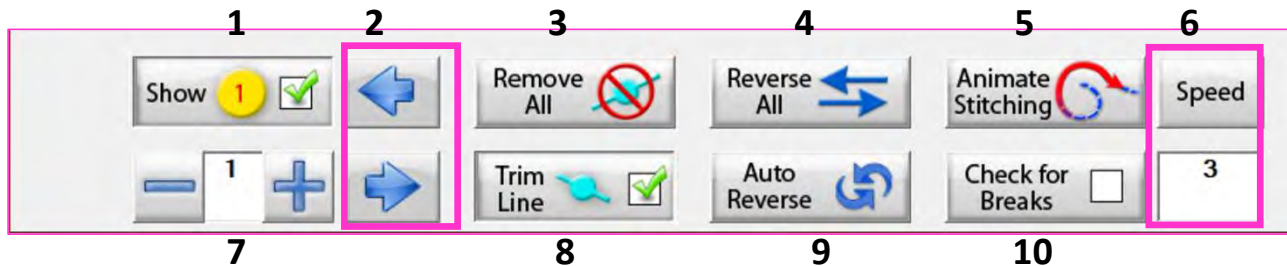

- 1. Show Section Numbers** — Enables and Disables showing section numbers.
- 2. Move Section Numbers** — Moves the location of the section number on the pattern. It does not change the order of the pattern.
- 3. Remove All Trim Lines** — Removes all trim lines from the pattern and places a line that will be sewn in its spot.
- 4. Reverse All** — Reverse the sewing path of the entire selection.
- 5. Animate Stitching** — Will show the pattern being traced in the order that it will sew on the quilt.
- 6. Animation Speed** — Set the speed of the animated stitching.
- 7. Section Number** — When you set this to a section number, then tap on a section it will change that number to the one you want. This allows you to manually change each section number.
- 8. Show/Hide Trim Lines** — Enables and Disables trim lines from being shown.
- 9. Auto Reverse** — Will optimize the pattern automatically, in the reverse direction it started at.
- 10. Check for Breaks** — when enabled you will be prompted to remove trim lines during animated stitching.

Optimize

Power Placement continued. . . Quilting Interface Screen

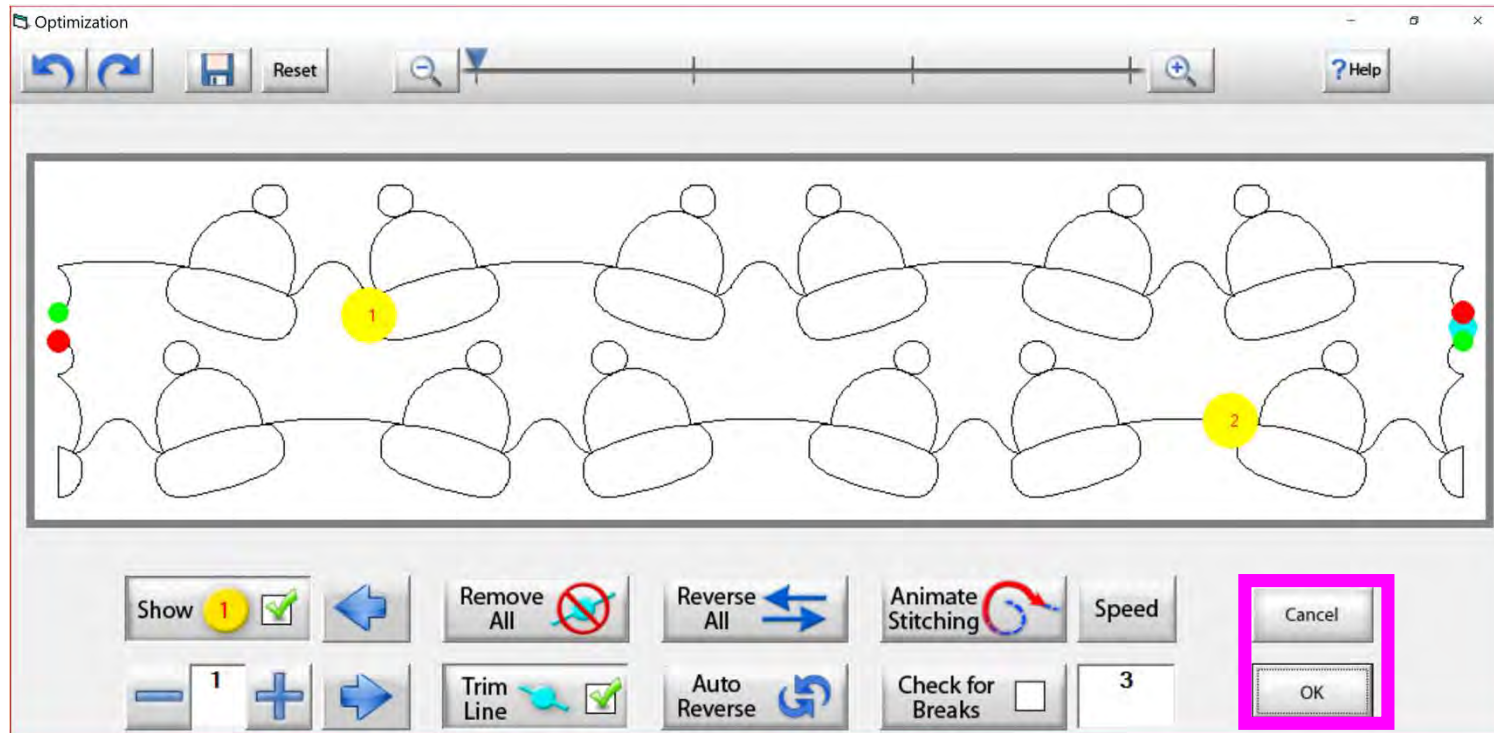

Tap “OK” to accept the changes you have made to your design, or “CANCEL” to discard the changes and it will take you back to your quilting interface screen.

Optimize

Power Placement continued. . . Quilting Interface Screen

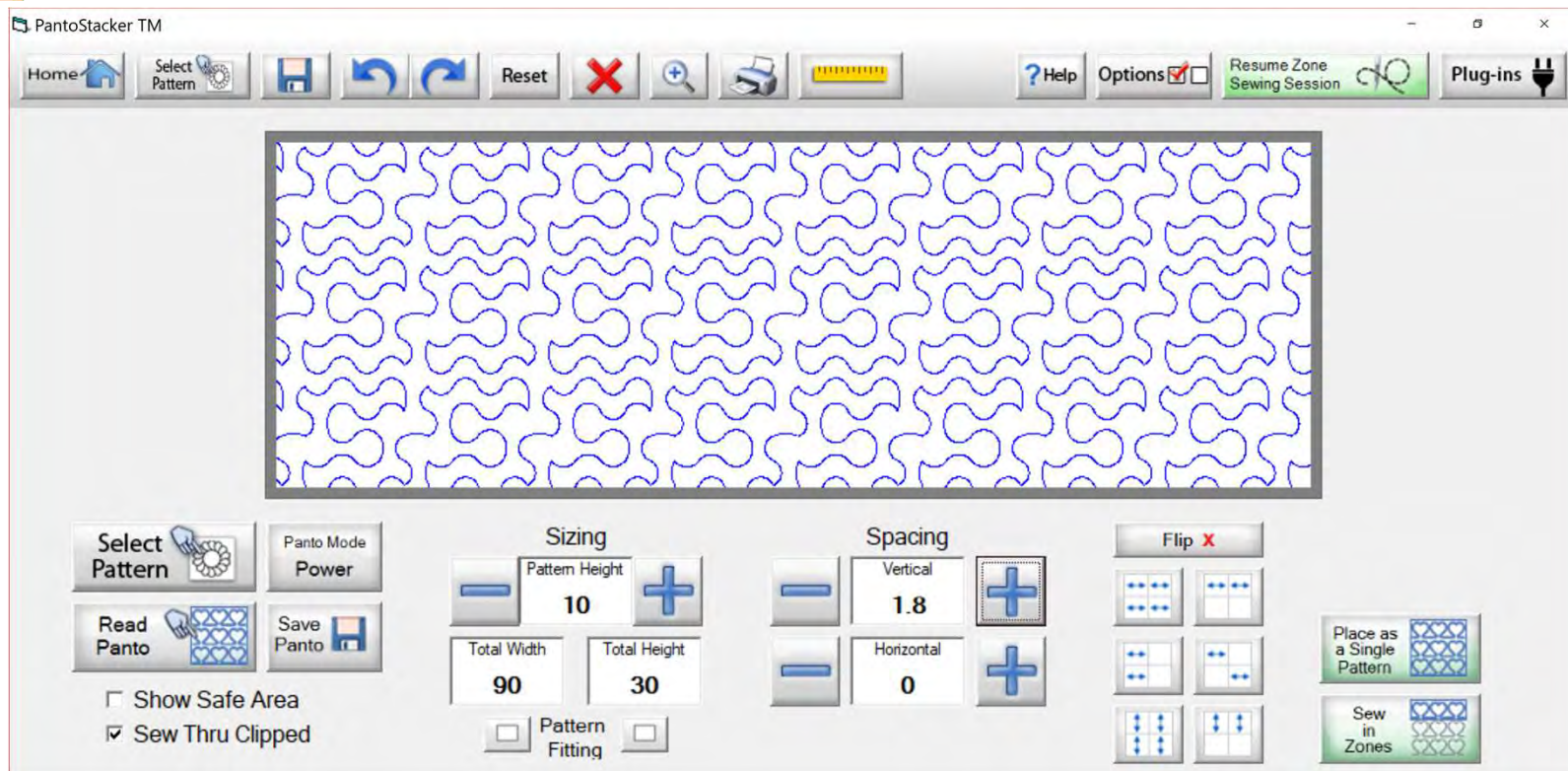

Select your design in your “PantoStacker” screen, make any adjustments you need to quilt your desired look. I adjusted the vertical spacing. Click on “Sew in Zones.”

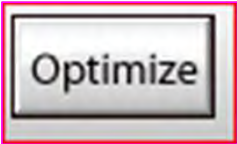

Power Placement continued. . . Quilting Interface Screen

The screenshot shows the Quilting Interface software window. The main area displays a quilt pattern with a repeating wavy design. A vertical trim line is visible on the right side, marked with a blue dot and a pink circle. The software interface includes a menu bar (File, Help), a toolbar (Settings, Show Trim, Optimize, Zone Utils), and a status bar (Help, Options, Plug-ins). At the bottom, there are several control panels: "Zone - Center" with instructions and a "Zone 1" input field; a "Zone Manager" panel with a diagram and various settings (Sew Speed, Stitch per Inch, Placed Height, Placed Width); and a "Sew" panel with icons for Release Carriage, Repair Pattern, Pull Bobbin, Trace, and Sew. The page number "150" is visible in the bottom right corner.

Trim line

This is your "Quilting Interface" screen, notice on my design I have one trim line. A trim line is a section of your design where your machine will stop sewing, so you can pull your bobbin thread, before moving to the next section to continue sewing. We want to get rid of the trim line and make our pantograph one continuous pantograph so our sewing machine will not stop. To get rid of this trim line Click on "Optimize."

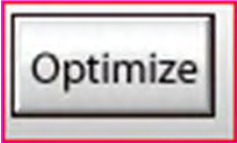

Power Placement continued. . . Quilting Interface Screen

Start point first section

End point section two

End point first section

Trim line

Start point section two

Show 1

Remove All

Reverse All

Animate Stitching

Speed

Cancel

Trim Line

Auto Reverse

Check for Breaks

OK

Let's get rid of that pesky old trim line. You can click on "Remove All" to get rid of it with the click of the button or you can click on "Check for Breaks" while you are "Animating Stitching" it will stop the Animation and ask if you want to remove the break. Click on yes, and it will proceed to the next until your design is finished with the "Animate stitching."

Optimize

Power Placement continued. . . Quilting Interface Screen

Start point first section

End point section two

End point first section

Trim line

Start point section two

Do you wish to remove this break?

Yes No Cancel

Show 1 Remove All Reverse All Animate Stitching Speed Cancel

Trim Line Auto Reverse Check for Breaks 1 OK

Notice that it stopped the Animation sewing process when it came to a trim line it is also a break in the design. The screen popped up to ask if I want to remove this break? "YES" I do so click on "yes" and it will remove that trim line break.

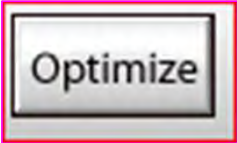

Power Placement continued. . . Quilting Interface Screen

Start point first section

End point section two

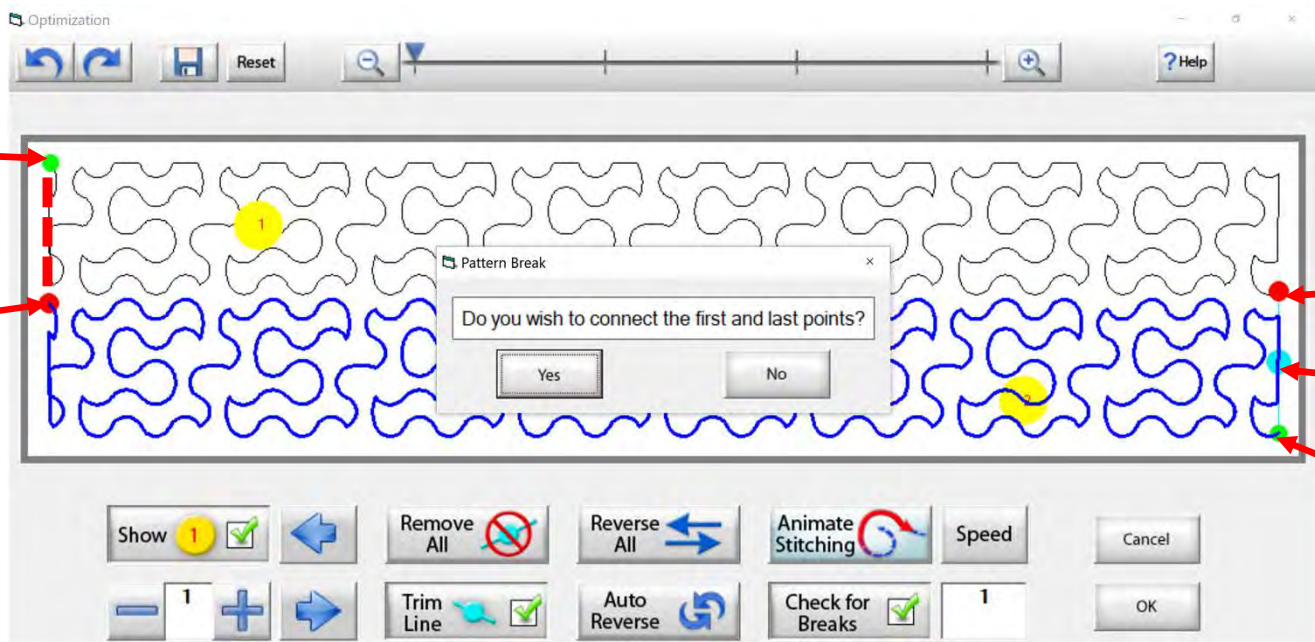

End point first section

Trim line

Start point section two

It will proceed with the “Animation Stitching” until it get to the end of you design another screen will pop up asking you “Do you wish to connect the first and last pintps?” This means the start point of your first section and the end point of your last section. I always say no. As you can tell with this design it would not hurt your connection line will be on the edge of the design.

Optimize

Power Placement continued. . . Quilting Interface Screen

Start point

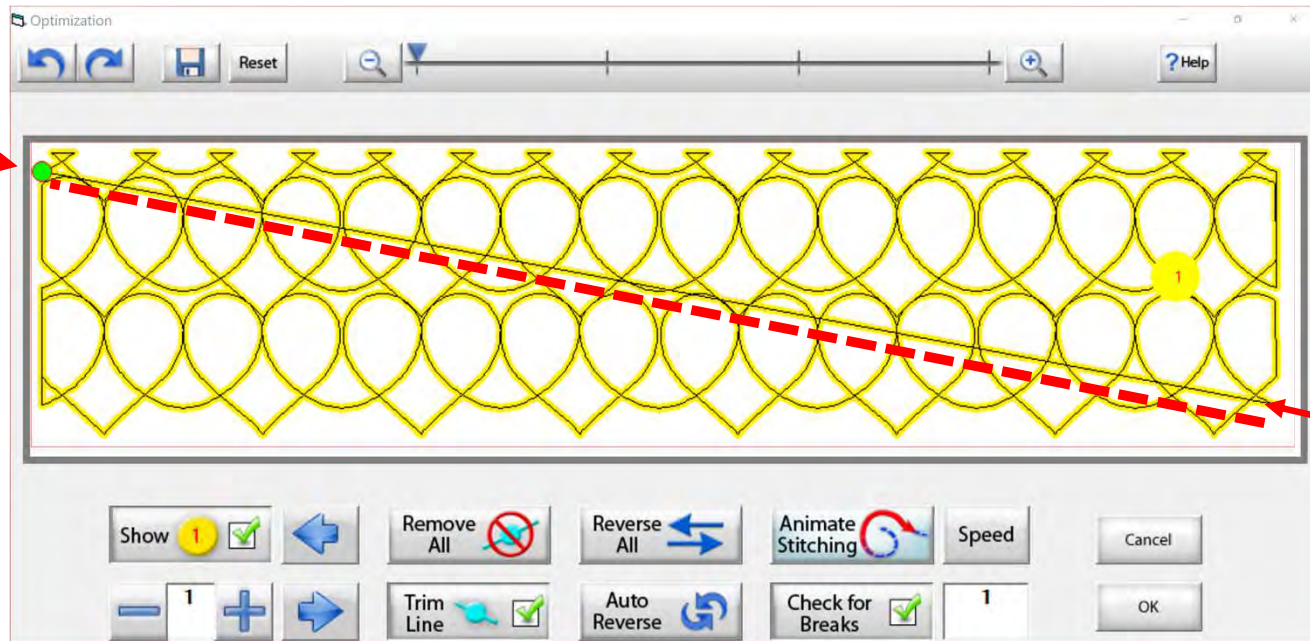

End point

The hearts design if connect the first and last points then you will get a sewing line across your design. You can change the speed of the “Animated Stitching” from 1 being the slow to 5 being the fast.

Optimize

Power Placement continued. . . Quilting Interface Screen

Start point

End point

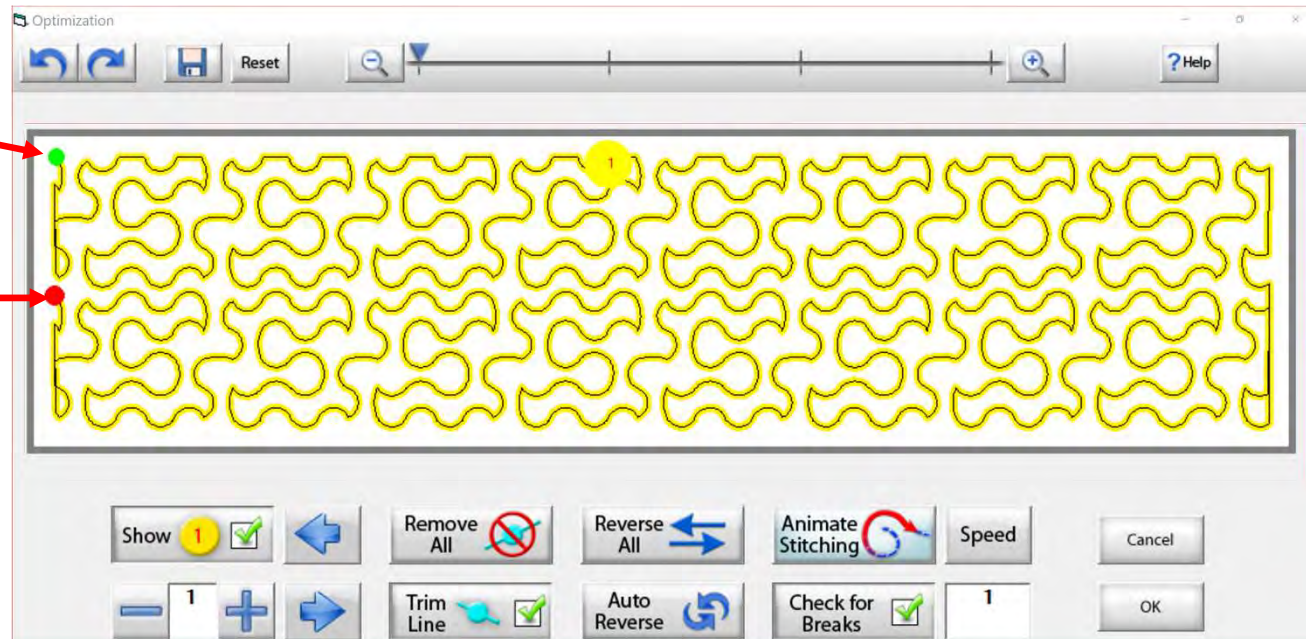

See how we have changed the pantograph design and how it will sew. Now there are no breaks or trims on the design, you only have one "start point" and one "end point." Play around in simulation mode and get to know how to use the optimization better.

Optimize

Power Placement continued. . . Quilting Interface Screen

Start point

End point

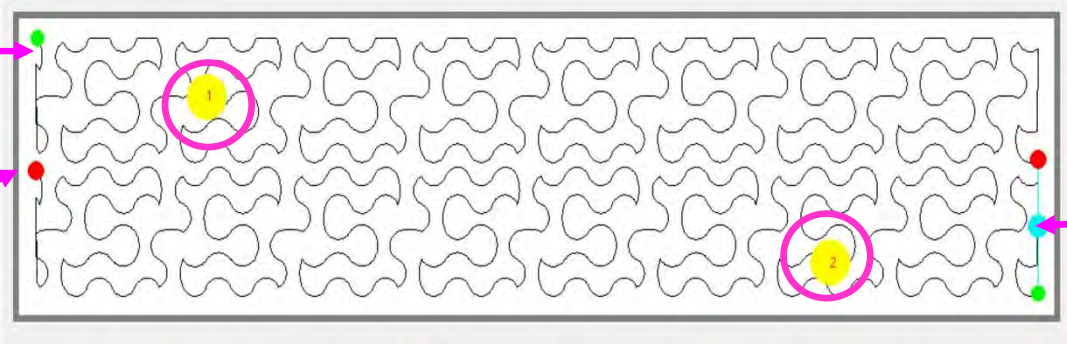

Trim line

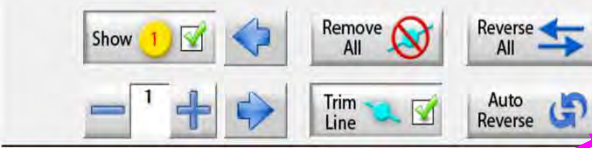

Trim line

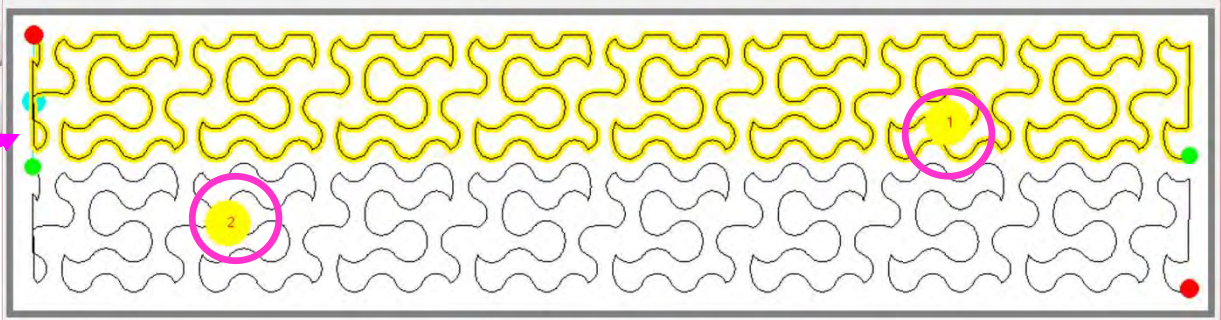

“Reverse All” reverses the direction of your design. Notice on the top where your trim line is. On the second screen it has moved to the other side.

Power Placement continued. . . Quilting Interface Screen



6. Now you don't have to open the "Toolbox" to make a single stitch. Click on "Single Stitch" button any time when connected to the automation. This handy button is found at the top of the "Quilting Interface" screen next to "Optimize."







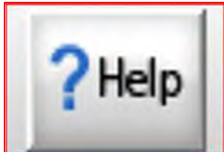

Power Placement - Fixed
The pattern is placed and ready to sew.

Placement	Power	
Fill Method	Placement	
Sew Speed	Medium	
Stitch per Inch	12	
Placed Height	6	
Placed Width	4.913	

Power Placement continued. . . Quilting Interface Screen



7. HELP allows you to access the help files and get more detailed information about QuiltMotion/QCT software.

 <p>Pantograph Training Advanced</p>	 <p>Pantograph Training Basic</p>	 <p>Pantograph Training Entry Level</p>	 <p>Pantograph Training EZ</p>	 <p>Pantograph Training Power</p>	 Pantograph Pantograph Training
 <p>Select & Sew</p> <p>Select and Sew Training</p>	 <p>Setting the Safe Area</p>	<h2>More Help Files Coming soon.</h2>			

Power Placement continued. . . Quilting Interface Screen

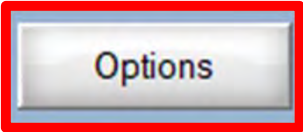

8. OPTIONS access the "Preferences Menu."

QuiltCAD and PatternCAD helps you create a new design or adjust an existing design to quilt.

Change the color of your lines, nodes, handles, mirrors, or trims. Just click on one of the buttons and change to a color of your choice.

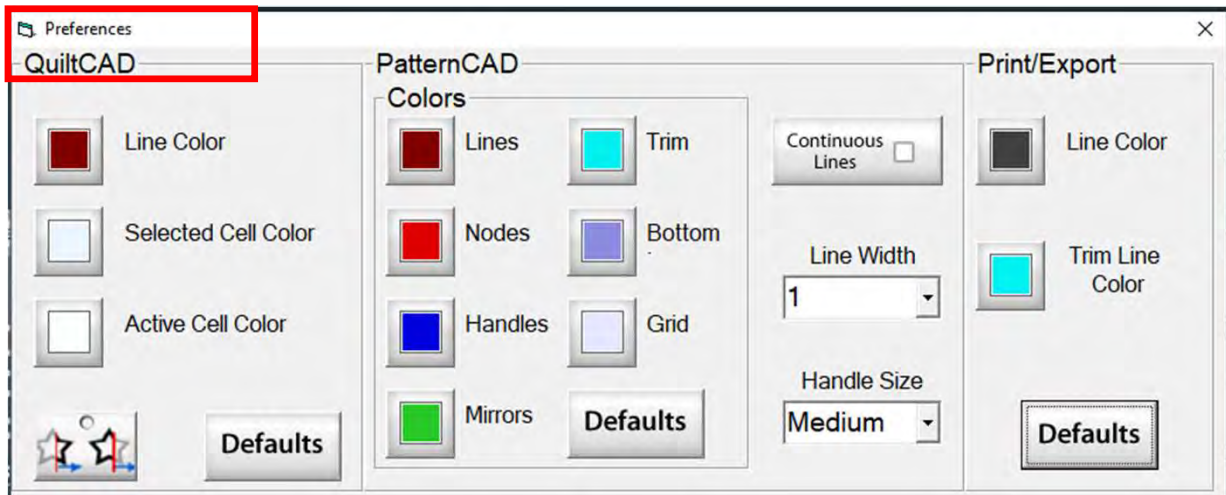

Print/Export can only be used with QuiltMotion/Quilter's Creative Touch Pro



Options

Power Placement continued. . . Quilting Interface Screen

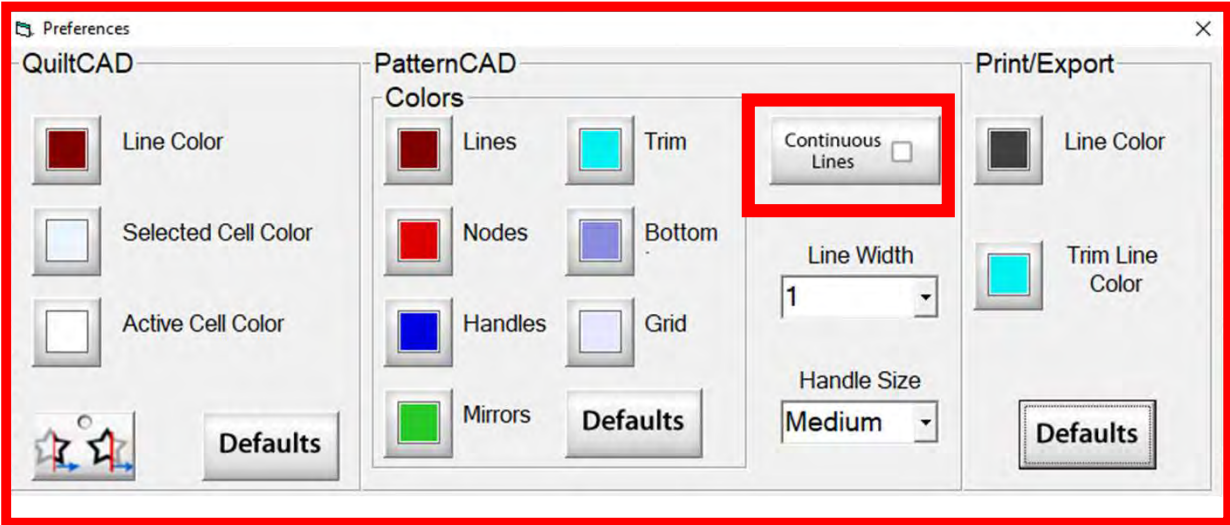

“Continuous Lines” if checked each node that you add will connect to the previous making continuous lines you won’t have any breaks.

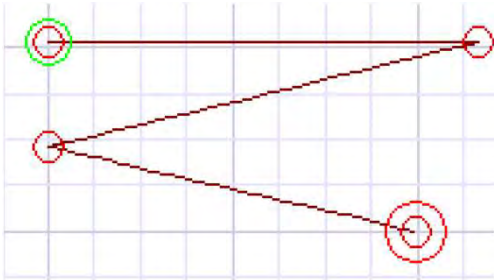

“Continuous Lines”
Checked

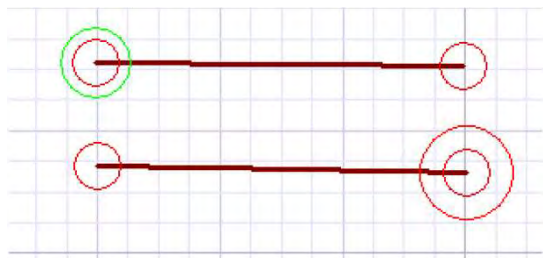

“Continuous Lines” not
Checked

Options

Power Placement continued. . . Quilting Interface Screen

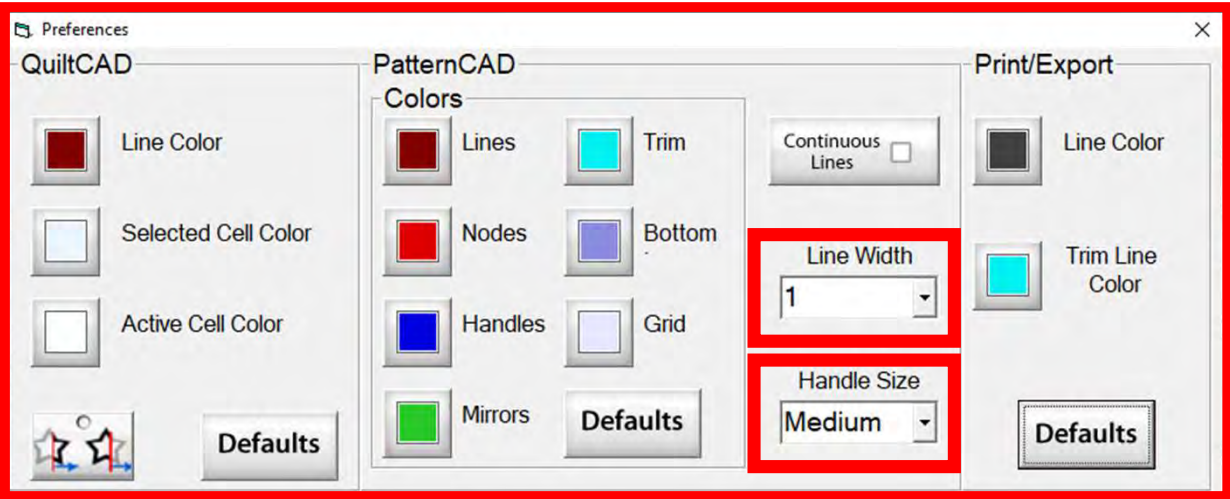

“Line Width” allows you to change the width of the lines in PatternCAD.

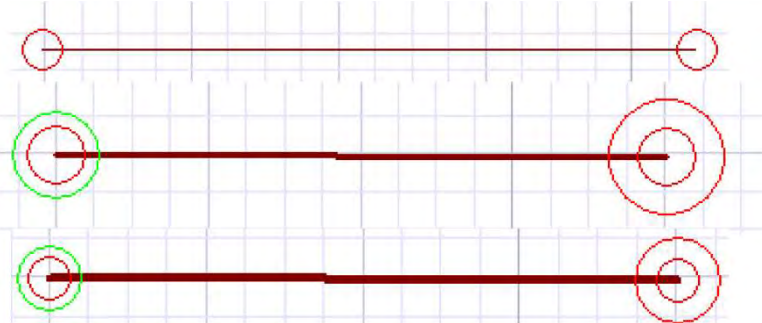

“Handle Size” changes the size of the handles, making them easier to select.

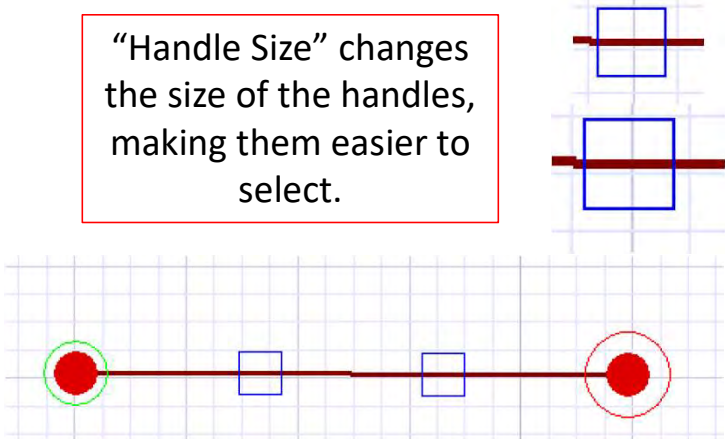

Options

Power Placement continued. . . Quilting Interface Screen

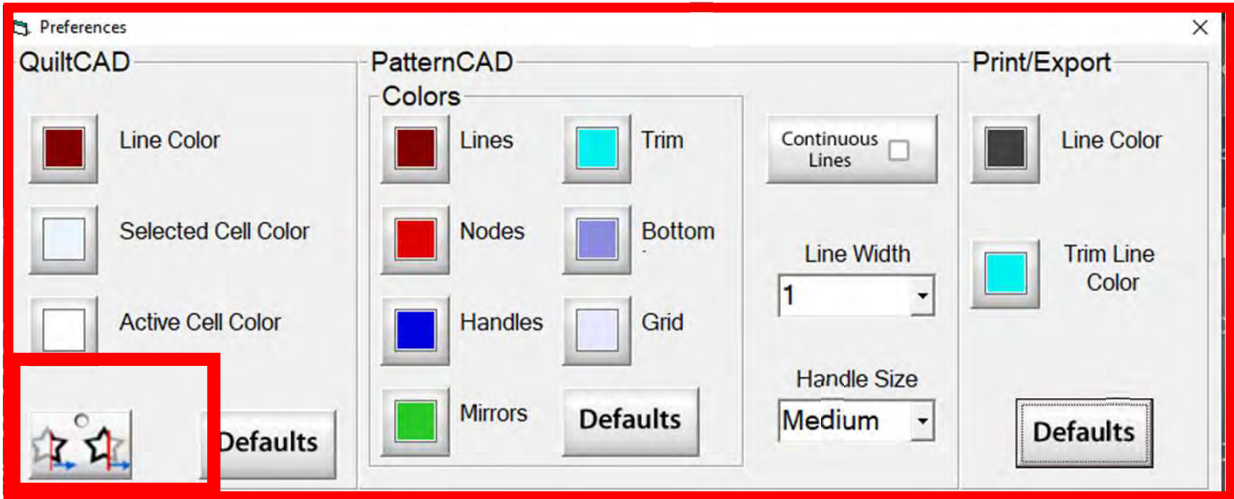

“Wrapping Tool” when enabled makes the pattern wrap around one edge of the quilt and place the remaining portion of the pattern on the other edge of your quilt.

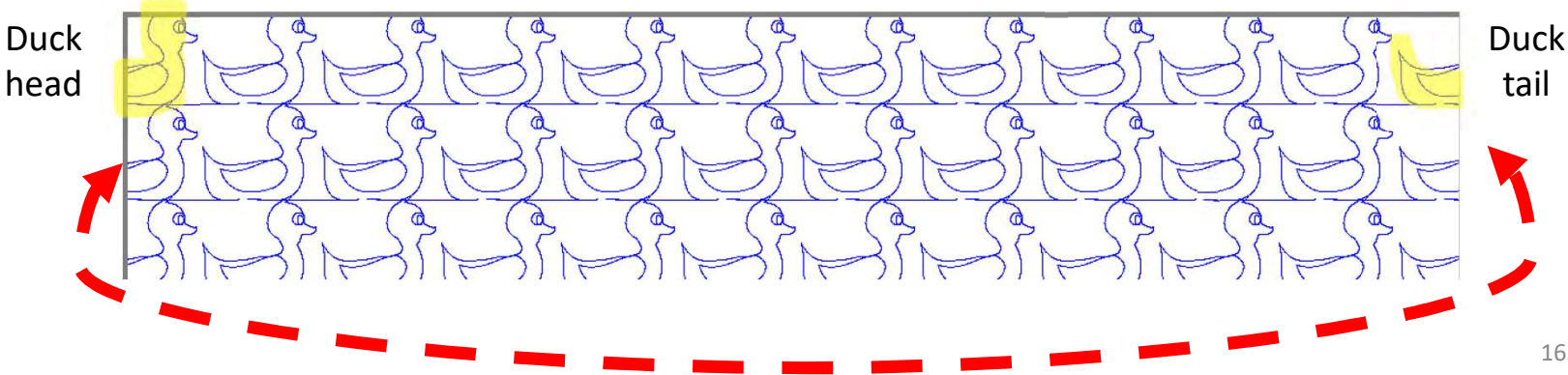

Options

Power Placement continued. . . Quilting Interface Screen

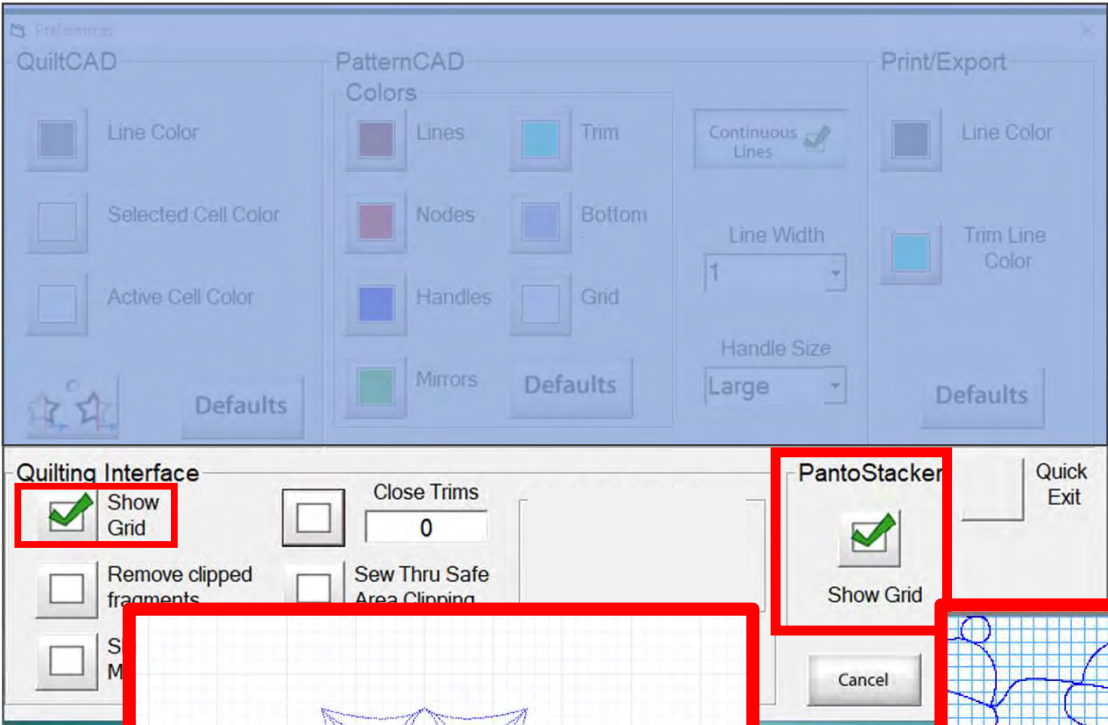

Select "Show Grid" your placement screens when you are in "PatntoStaker" or "Select & Sew" will open with the grid.

Pantograph Power Panto

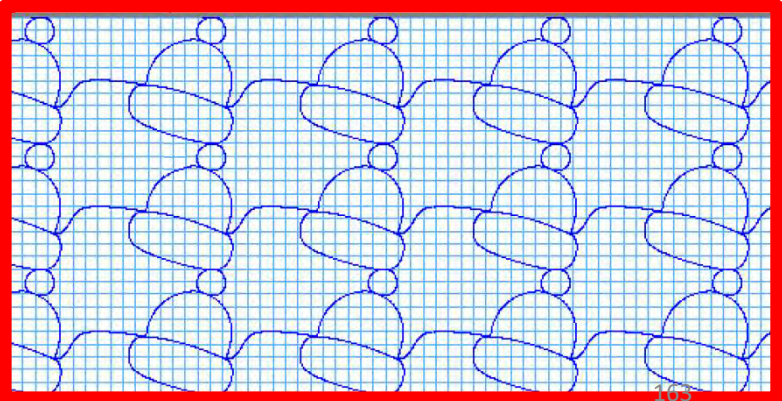
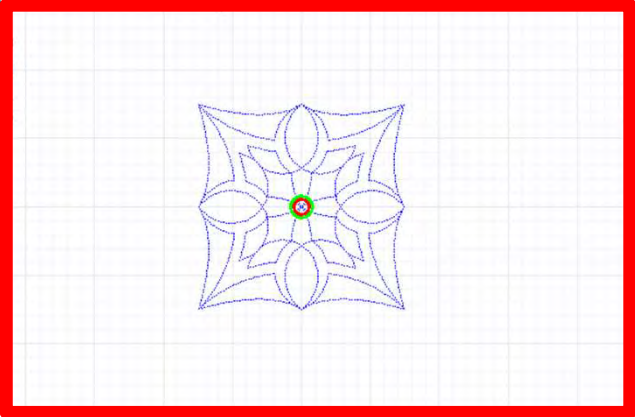

Options

Power Placement continued. . . Quilting Interface Screen

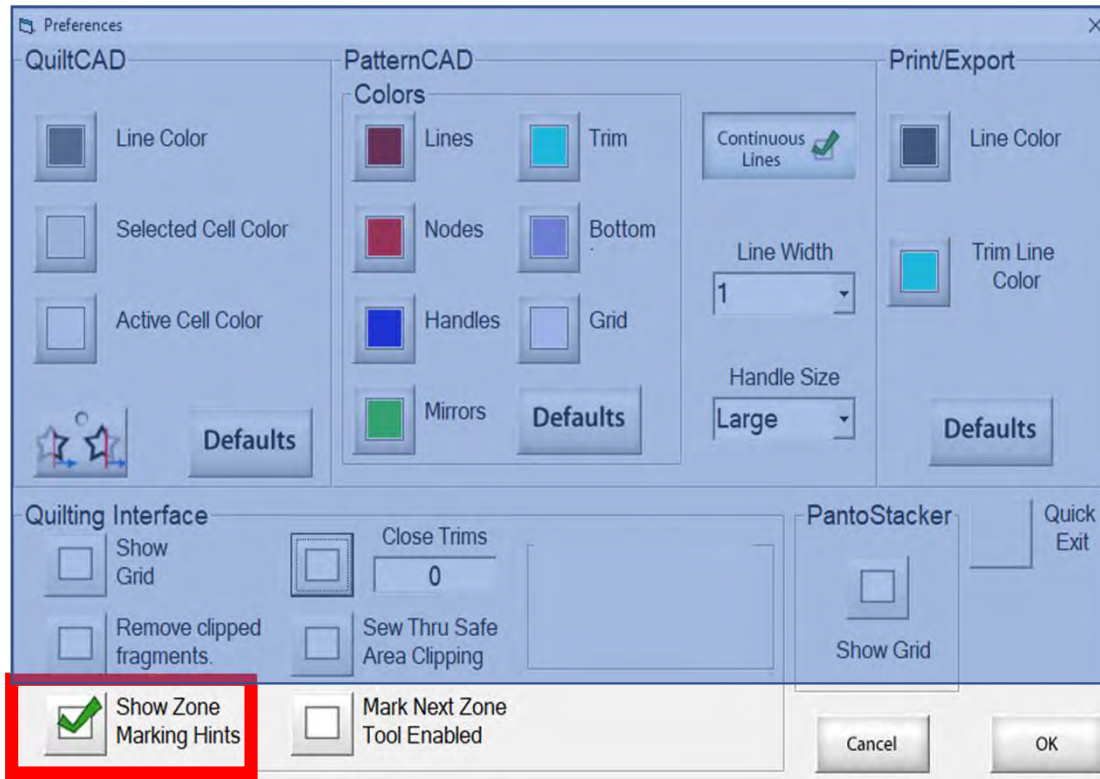

Zone - Center

Move the machine to the Quilt Top center if placing Zone 1, otherwise, move to the zone marker. Then, tap the placement button

Zone

1

Zone - Top Left

Position the zone using marks from a previously placed zone on the left.

Zone

1

“Show Zone Marking Hints” will prompt you where to mark your quilt to quilt the next zone/section.

Options

Power Placement continued. . . Quilting Interface Screen

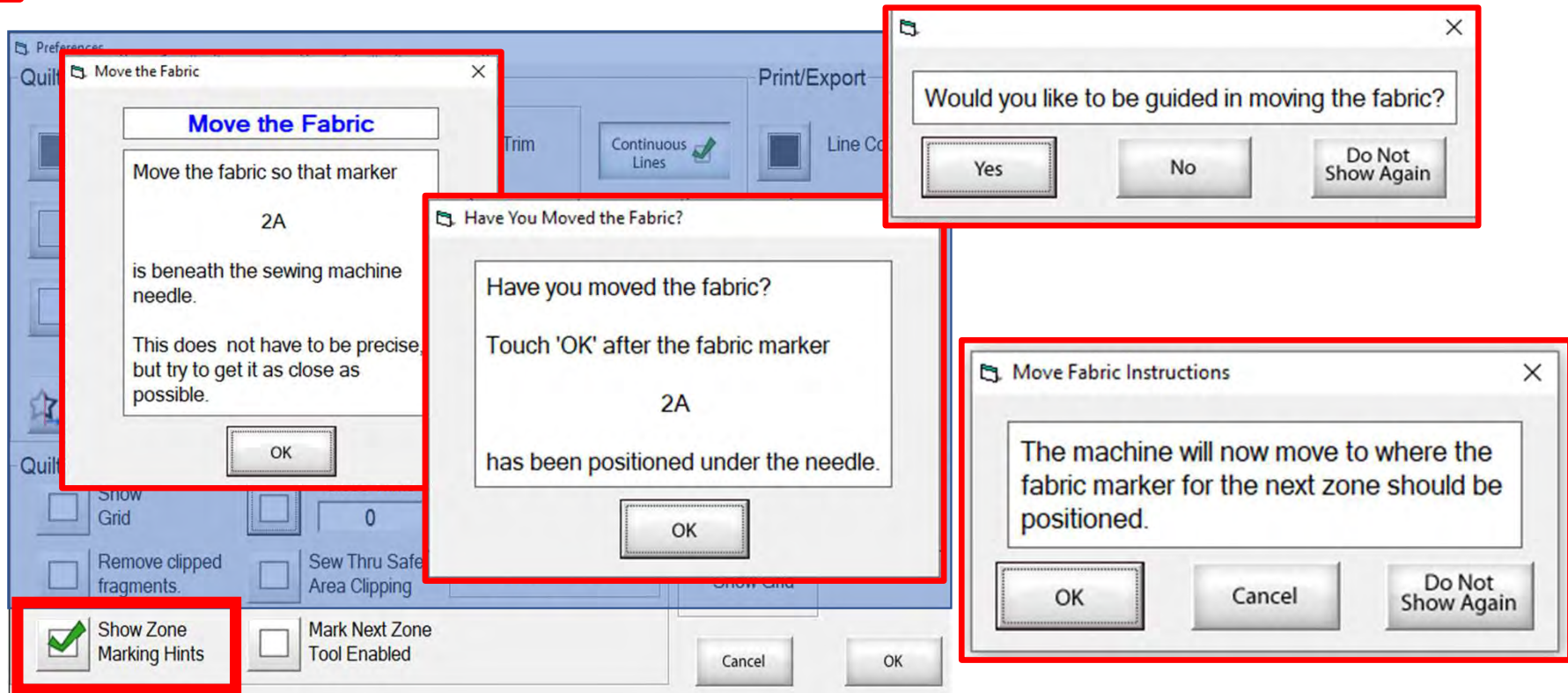

More "Show Zone Marking Hints" to help guide you through the quilting process.

Options

Power Placement continued. . . Quilting Interface Screen

The image displays several overlapping windows from a quilting software interface:

- Zone Finished:** A dialog box with the text "Zone Finished" and "The sewing of the ZONE is finished. You may advance to the next zone, if you are ready." Below this is a text box containing the number "1".
- Finished Zone! Proceed To Next Zone:** A dialog box featuring a diagram of a quilt block with heart-shaped patterns and arrows indicating movement directions.
- Move the Fabric:** A dialog box titled "Move the Fabric" with a blue header. It contains the text "Move the fabric so that marker 2A is beneath the sewing machine needle. This does not have to be precise, but try to get it as close as possible." and an "OK" button.
- Move Fabric Instructions:** A dialog box with the text "The machine will now move to where the fabric marker for the next zone should be positioned." and buttons for "OK", "Cancel", and "Do Not Show Again".
- Control Panel:** A background panel with various settings. A checkbox labeled "Mark Next Zone Tool Enabled" is checked and highlighted with a red box.
- Move Fabric Confirmation:** A dialog box at the bottom right asking "Would you like to be guided in moving the fabric?" with "Yes", "No", and "Do Not Show Again" buttons.

“Mark Next Zone Tool Enabled” helps you mark your quilt top placements before your roll or shift quilt to move to the next zone/section to resume quilting.

Options

Power Placement continued. . . Quilting Interface Screen

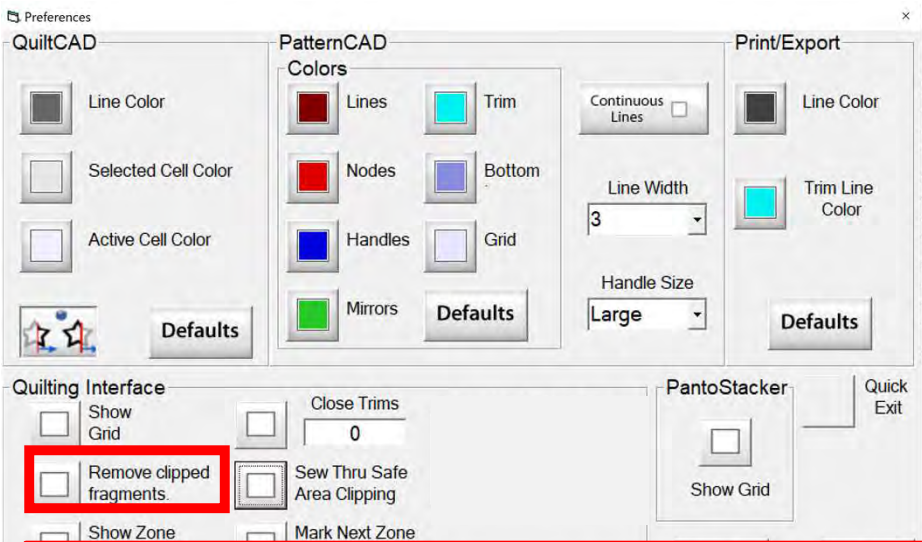

“Remove Clipped Fragments” unchecked, will sew to the edge of the small fragment section and stop asking for permission to move to the next section of the design. Your machine will stop at every section before it will sew to the next keeping that portion of the design and sewing it throughout your quilt.

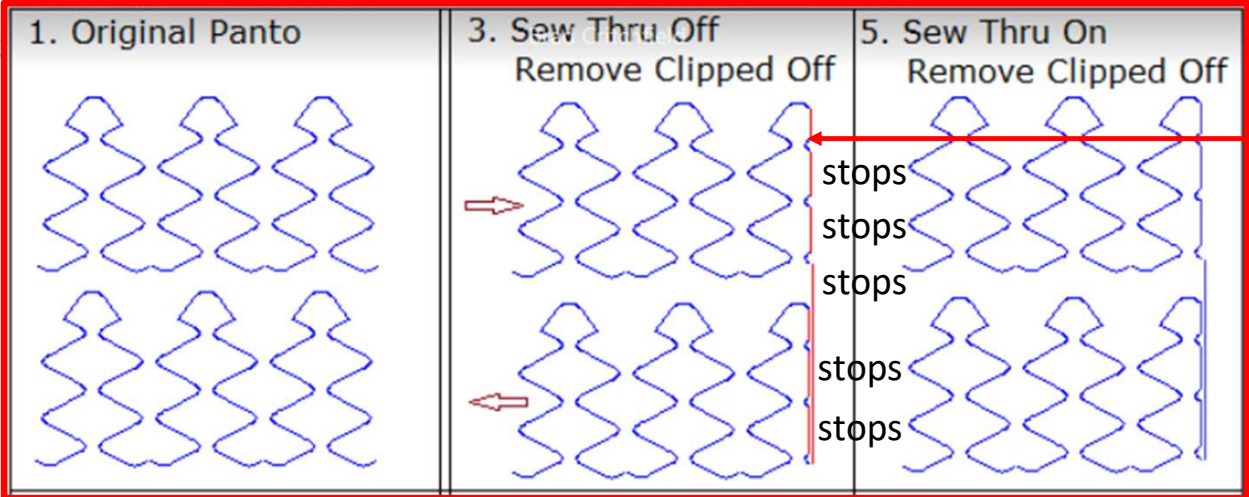

Sews small fragment section and stops, stopping after every fragment is sewn

Options

Power Placement continued. . . Quilting Interface Screen

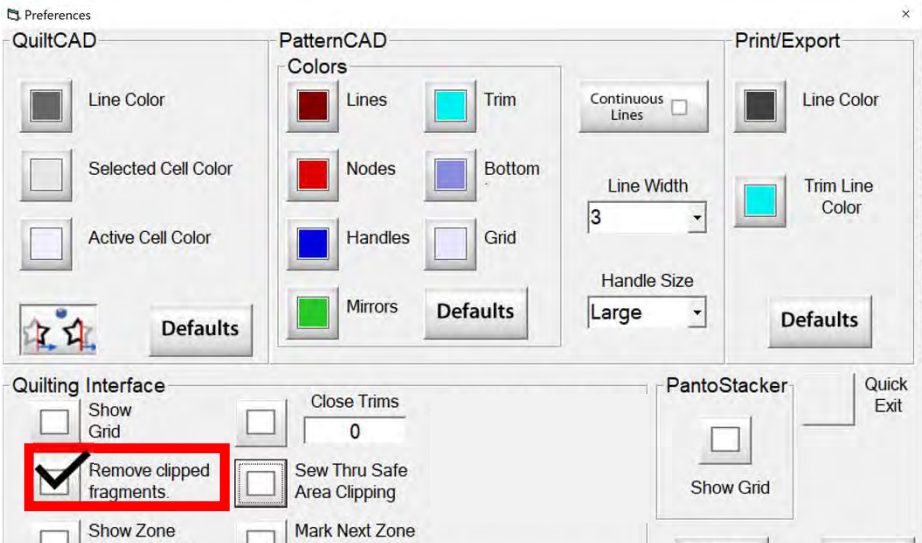

“Remove Clipped Fragments” checked, sews the edge of the small fragment section of the design and sews to the next keeping that portion of the design and sewing it throughout your quilt. No stopping!!!!

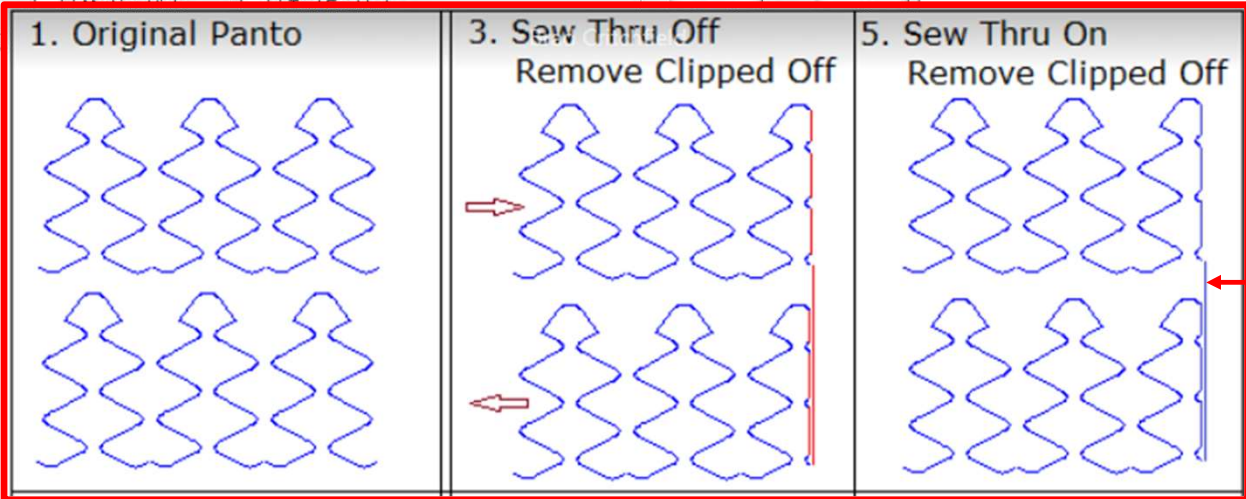

Sewed small Fragment to the next without stopping

Options

Power Placement continued. . . Quilting Interface Screen

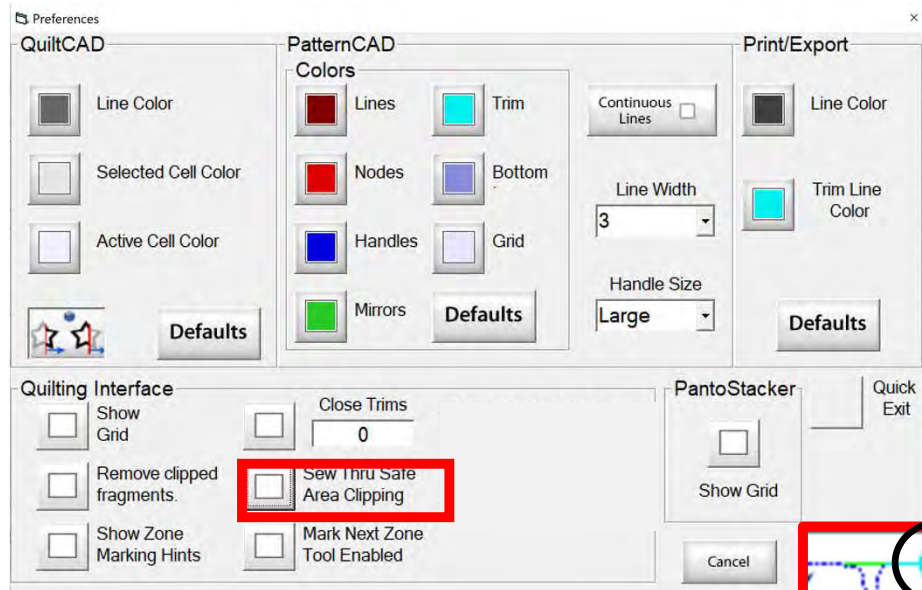

“Sew Thru Save Area Clipping” unchecked will stop quilting whenever there is a break in the design. Stopping and starting several times throughout your quilt. The blue dots are breaks and when the machine will stop then it will prompt you to move to the next where it will stop again.

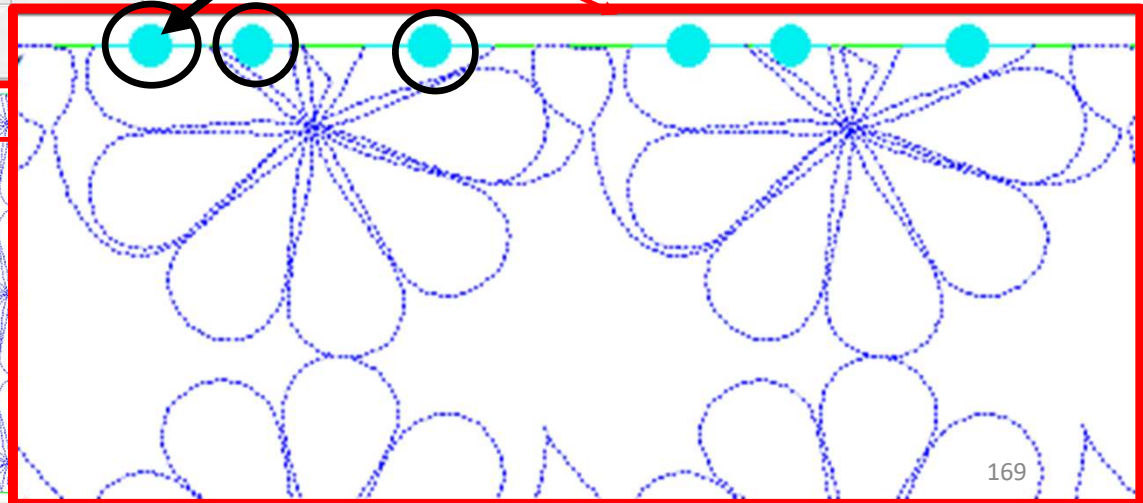

Options

Power Placement continued. . . Quilting Interface Screen

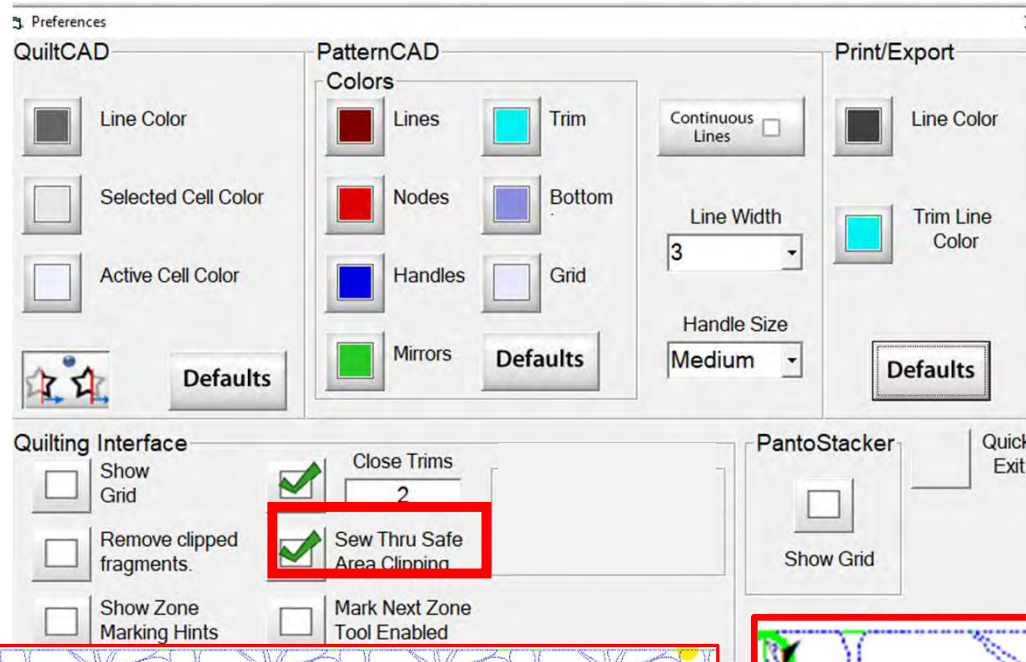

“Sew Thru Save Area Clipping” checked keeps sewing where there was a break in the design. It removes the break by inserting more stitches to fill in the break sewing to the next section of the design, no more stops the breaks are removed.

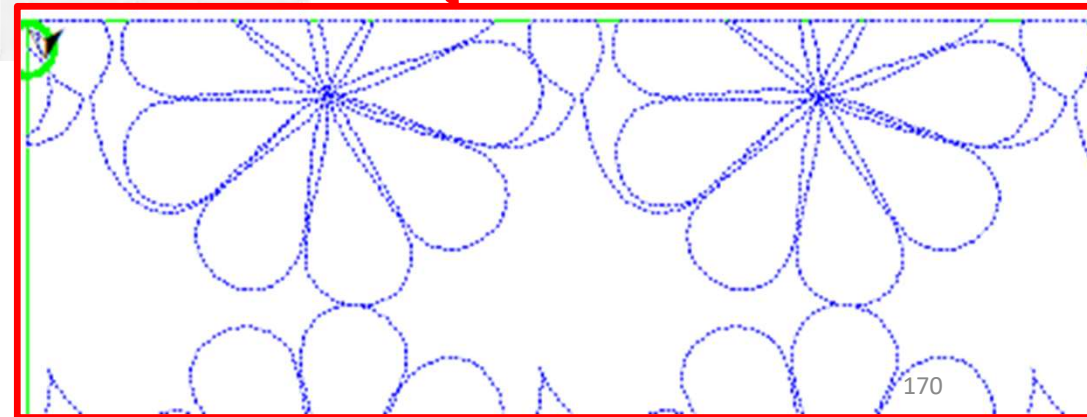
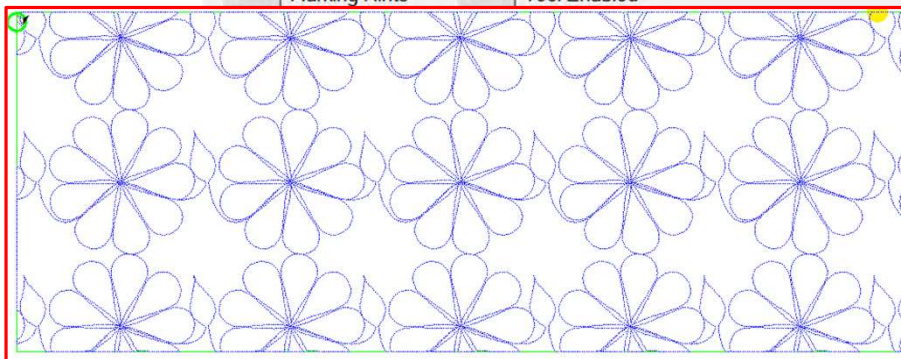

Options

Power Placement continued. . . Quilting Interface Screen

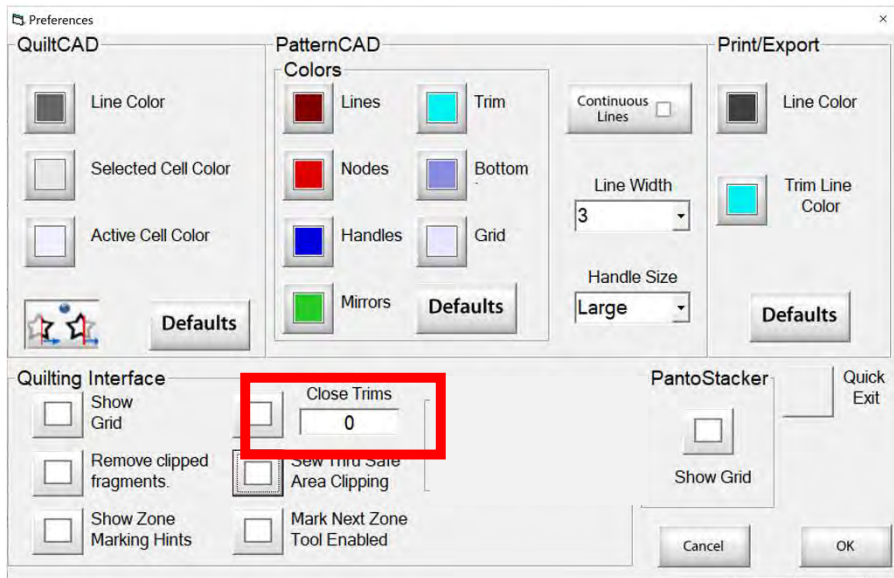

“Close Trims” unchecked will stop quilting at the end of the design before moving to the next design. Leaving a gap between designs will not be continuous.

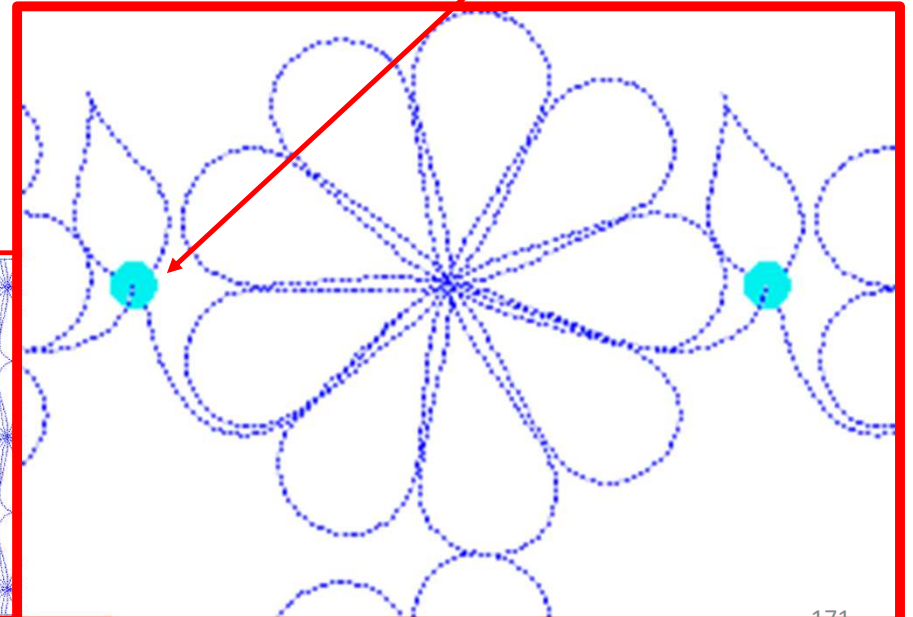
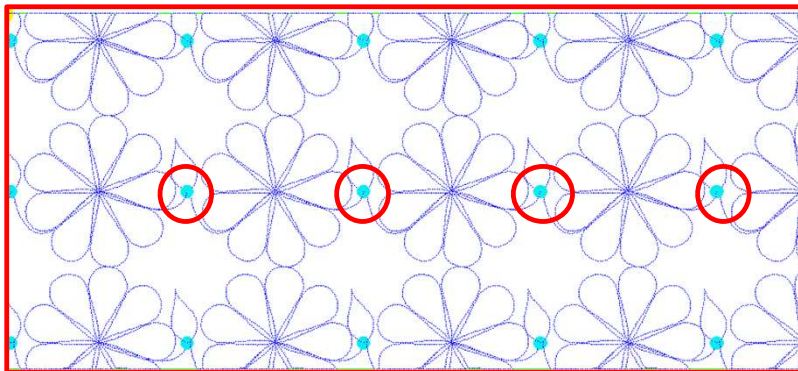

Options

Power Placement continued. . . Quilting Interface Screen

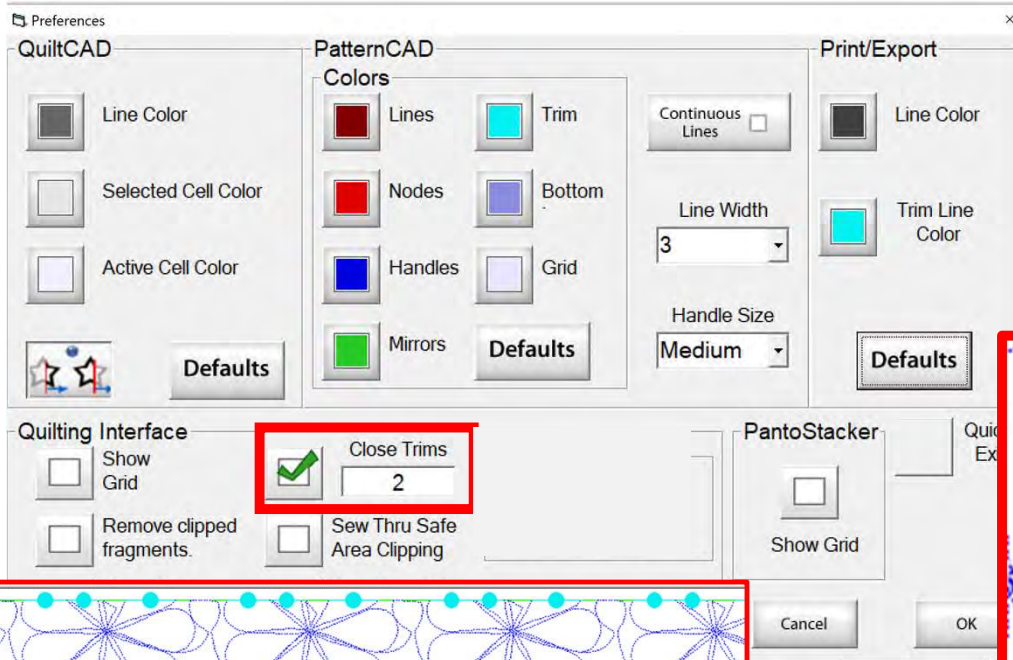

“Close Trims” checked will add stitches to the design to connect to the next design making it a continuous design across the quilt.

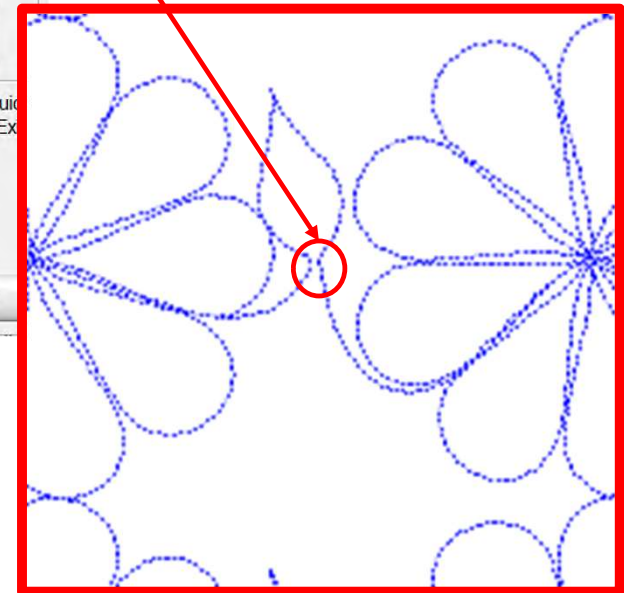
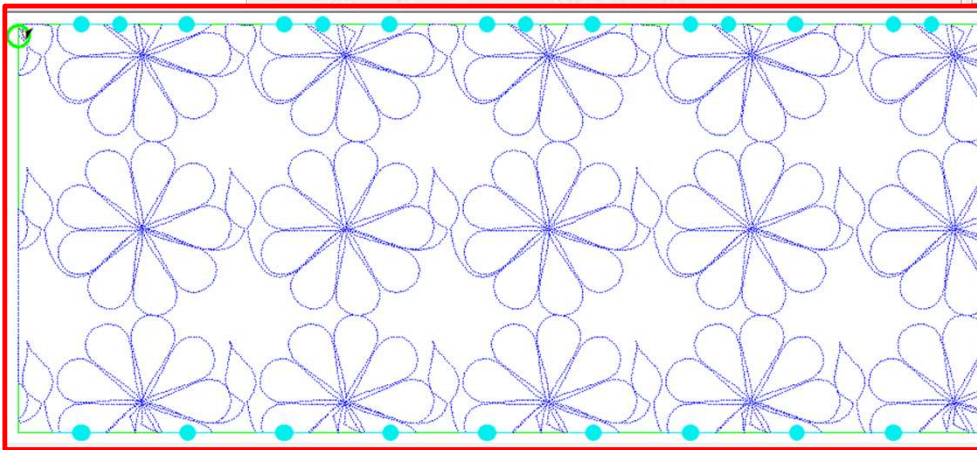

Options

Power Placement continued. . . Quilting Interface Screen

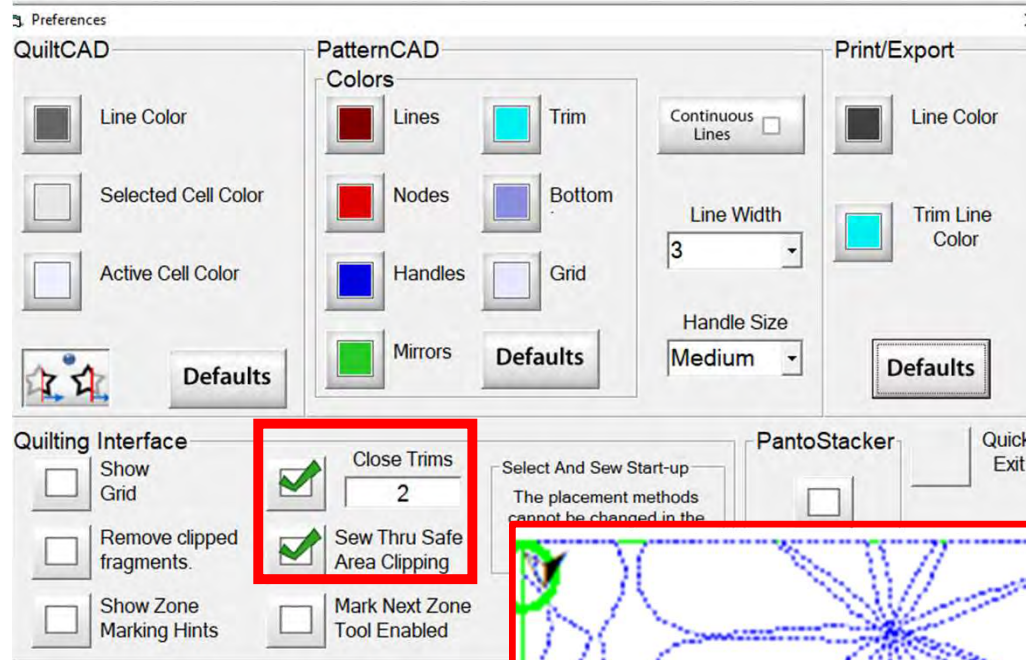

“Close Trims” & “Sew Thru Safe Area Clipping”

When both are checked, and your trims are at “2” you will have no breaks a pantograph design that will sew edge to edge without stopping!

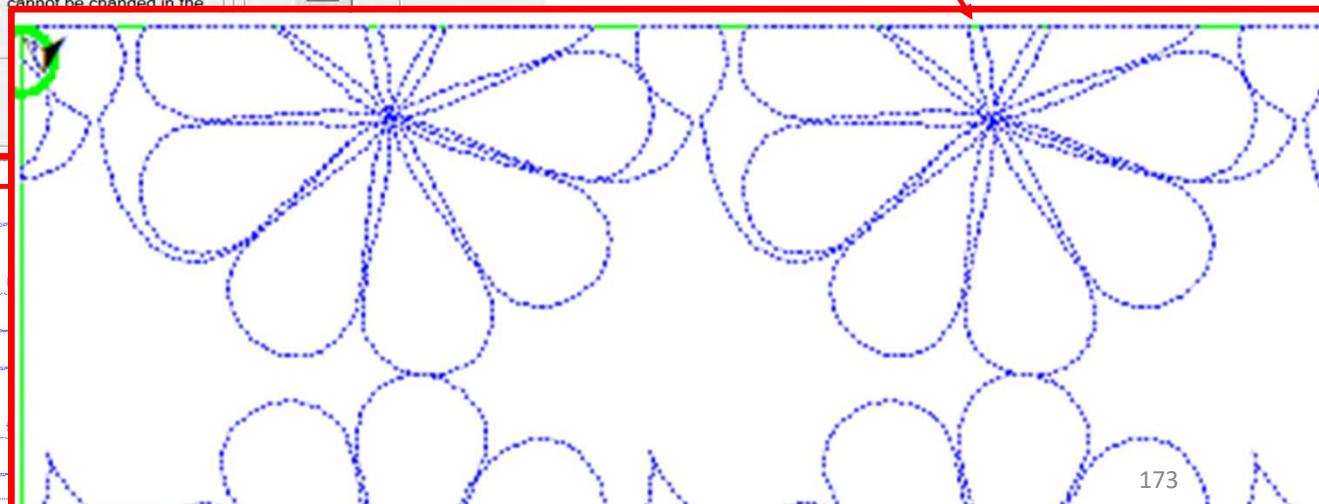
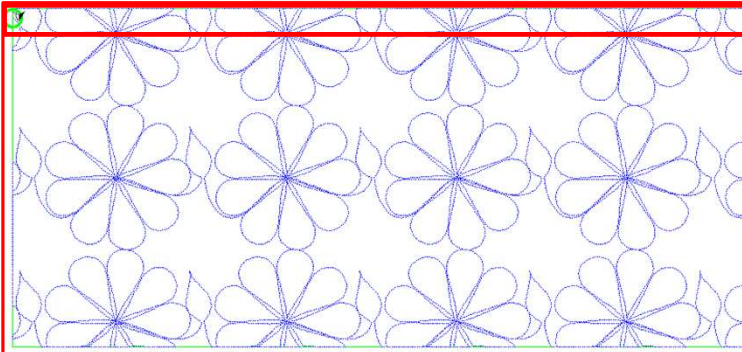

Power Placement continued. . . Quilting Interface Screen



9. PLUG-INS access the “Marking Tool” to help you place your design with precision and accuracy. If you have the Gold Card it will give you access advanced features such as “Fabric Compensation, “End Point Adjust” and “Pattern eClipse.”

Use Marking tool to mark around your block section

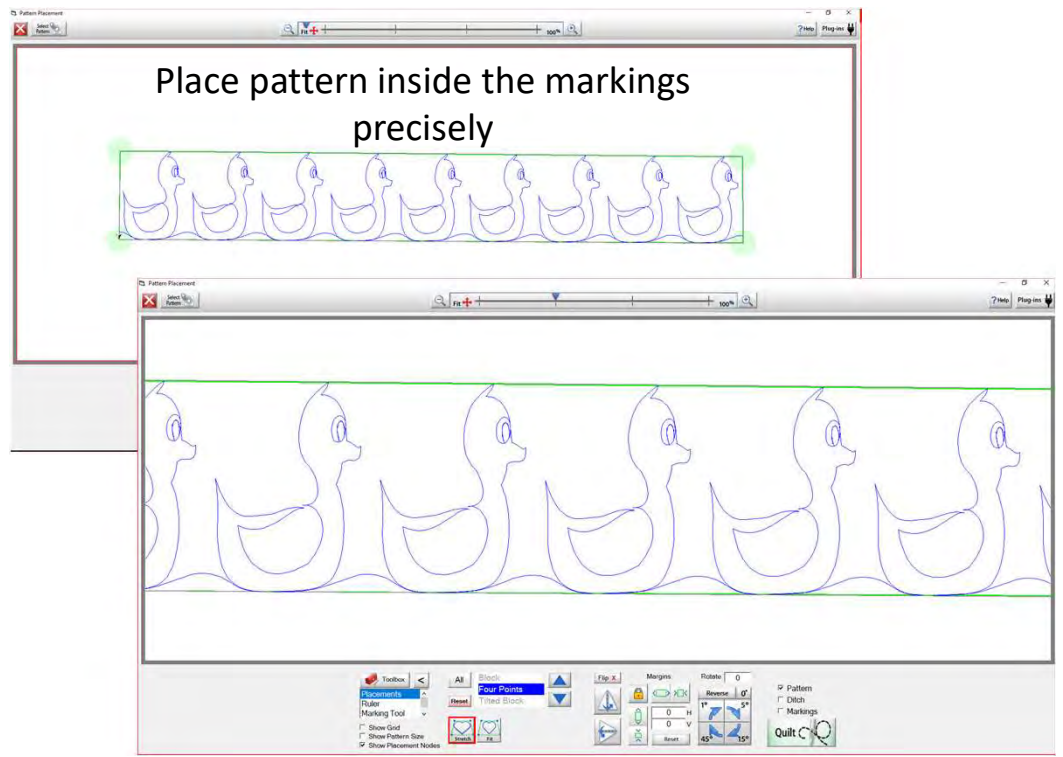

Power Placement Quilting interface Screen

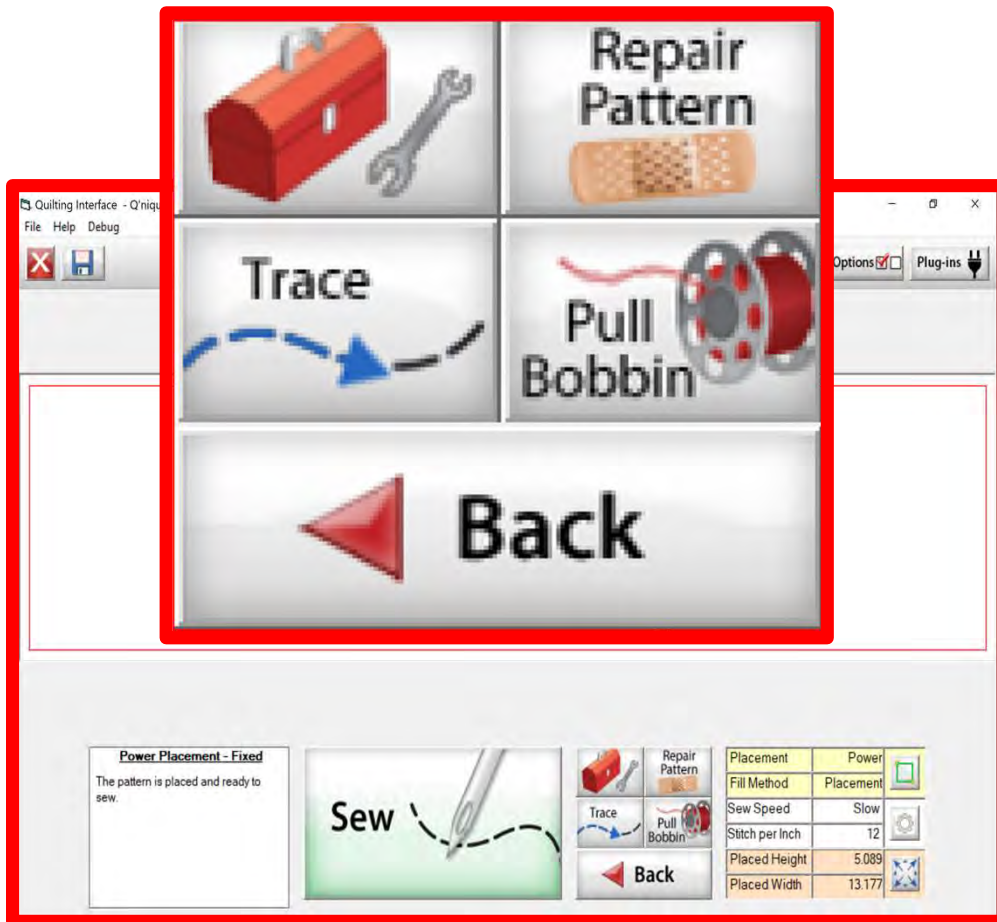

The “Quilting Interface” screen is the screen that you will sew your designs. This screen has features to help you sew your design such as the:

“Toolbox”

“Trace”

“Repair Pattern”

“Pull Bobbin”

“Back”

Learn the function of the buttons and how to use them.

Quilting Interface continued. . .

Toolbox

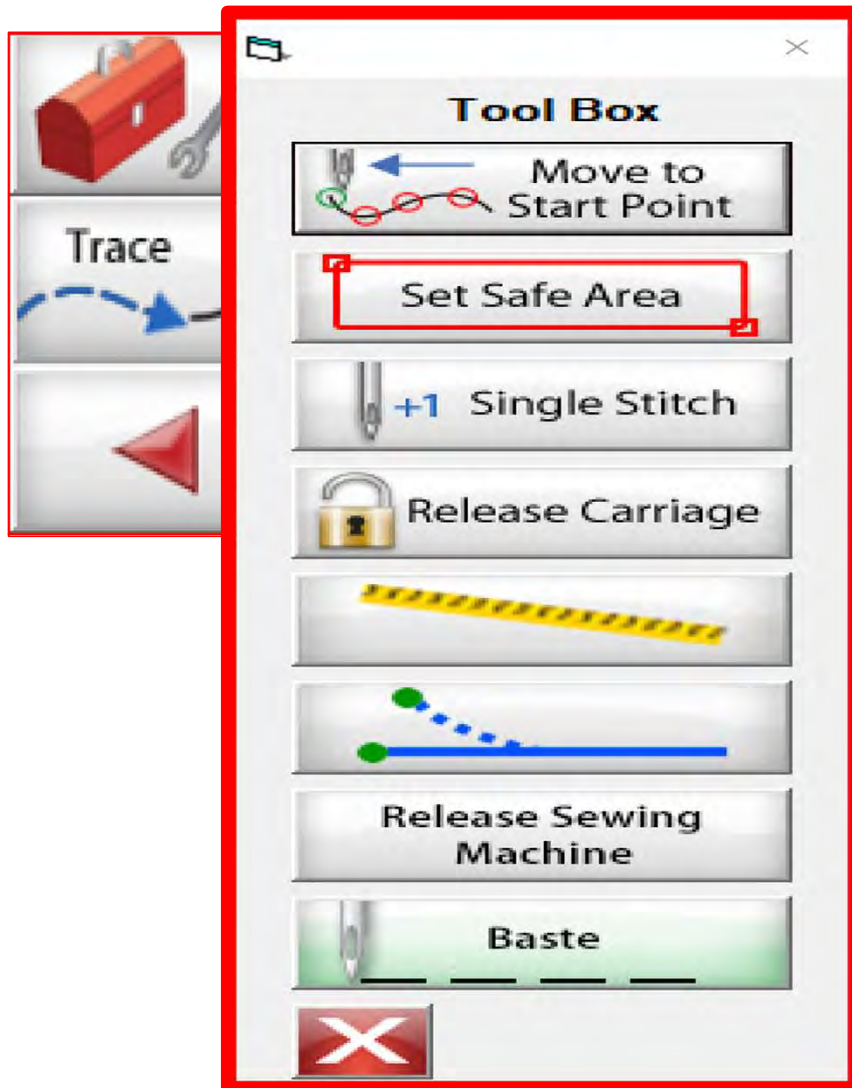

Inside the "Toolbox" are some useful tools to help you quilt your design.

Quilting Interface continued. . . **Toolbox**

***Note:** This "Toolbox" is a standard toolbox for the quilting interface. Not all the functions will work in certain areas.



Moves, your Machine to the start point of your design

Reset your "Safe Area"

Single stitch to pull up bobbin thread

Releases the Carriage the sewing machine sits on, to move to a new location

"Ruler" to measure your length and width

Aligns start point and end point placement of designs, to match up with the portion of the design already placed and quilted.

Releases, the sewing machine from the computer, allows you to sew without being connected to the automation

Baste large stitches to tack down quilt

Closes the "Toolbox" window

Quilting Interface continued. . . **Toolbox**



Moves your Machine to the start point of your design

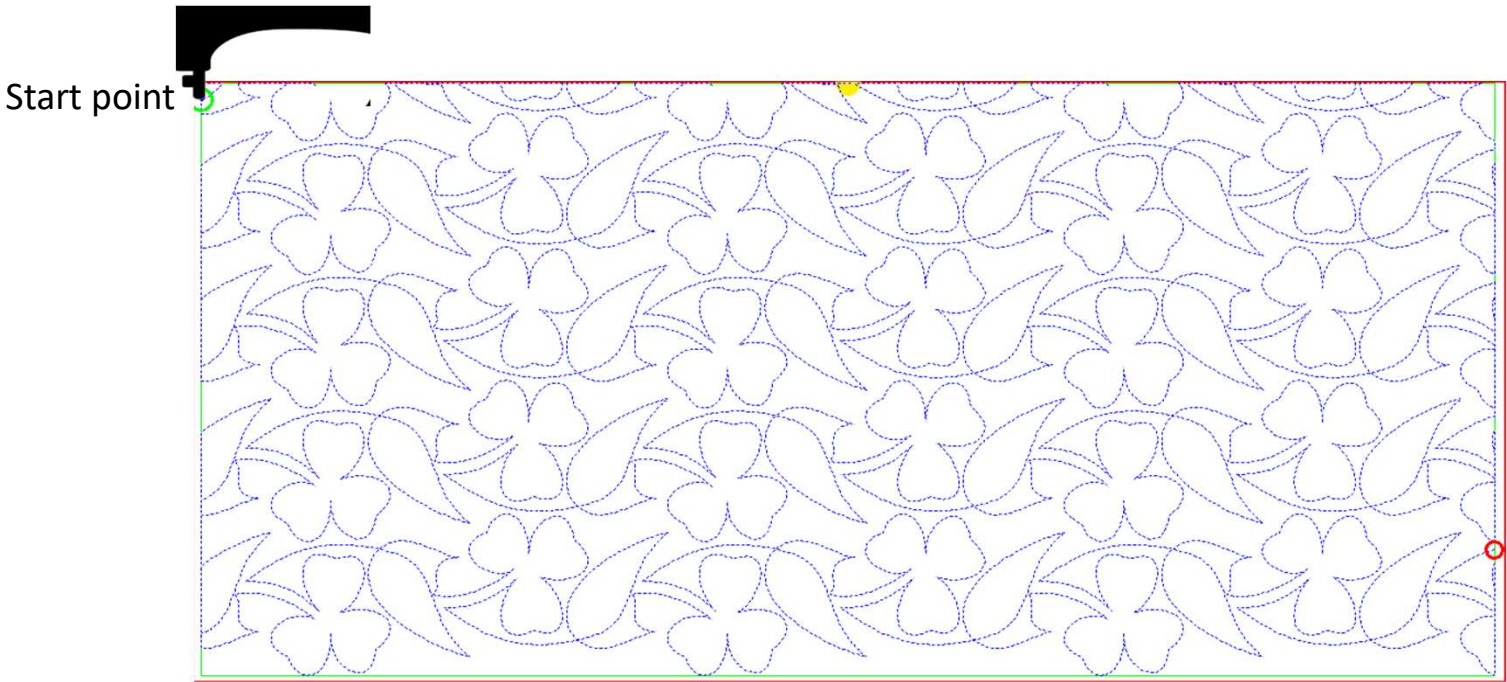

Quilting Interface continued. . . Toolbox

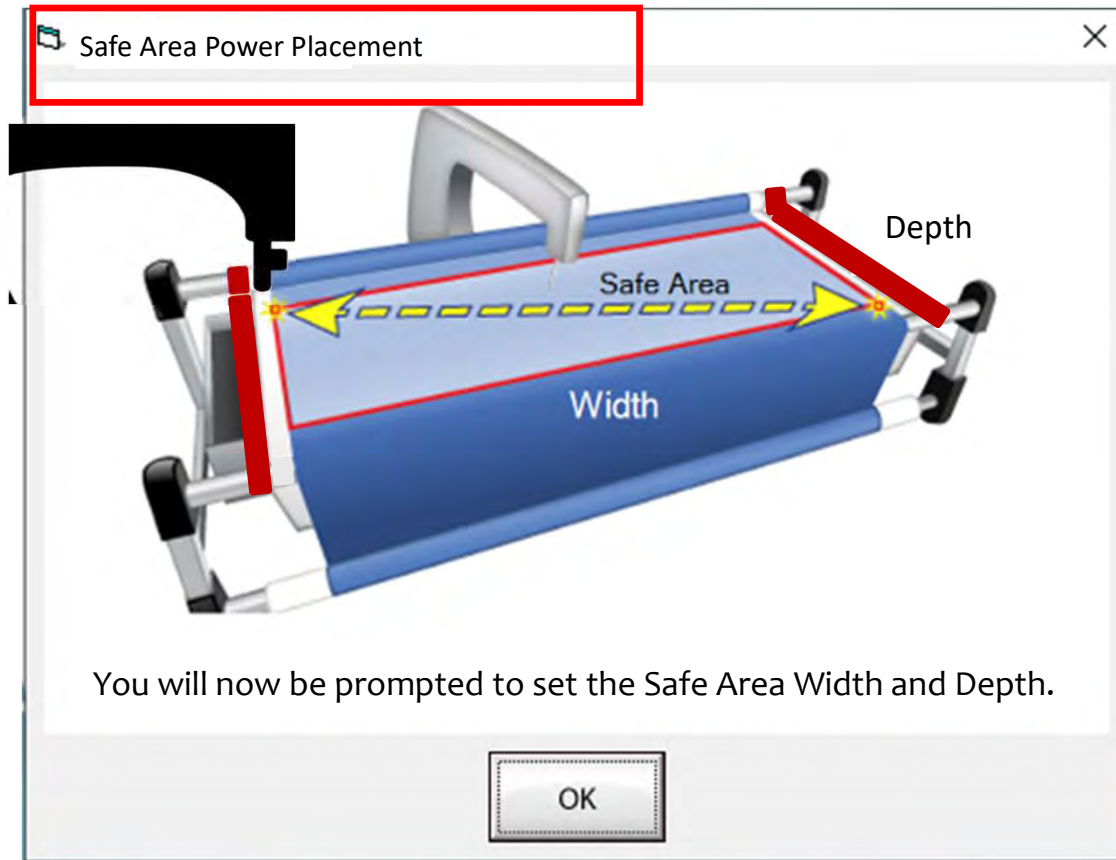

The “Safe Area” is your “quiltable,” quilting area. It will be different for every quilt. The “Safe Area” is defined by quilt size, machine throat and design. For pantograph edge-to-edge design you will want to set your safe area just off the edge of your quilt top so the design will sew off the edge slightly. How far off is determined by you and how wide your backing and batting are. Remember you always cut your backing and batting wider than your top. Let’s set the safe area.

Quilting interface continued... Toolbox

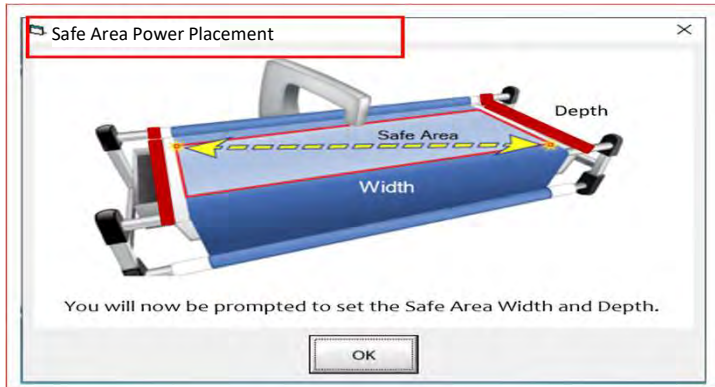

1. Move your machine off the quilt top to the top left corner until your machine's foot hits the take-up rail. Bring the machine forward just a slightly make sure the machine is on the batting about $\frac{1}{2}$ -1" off the quilt top.

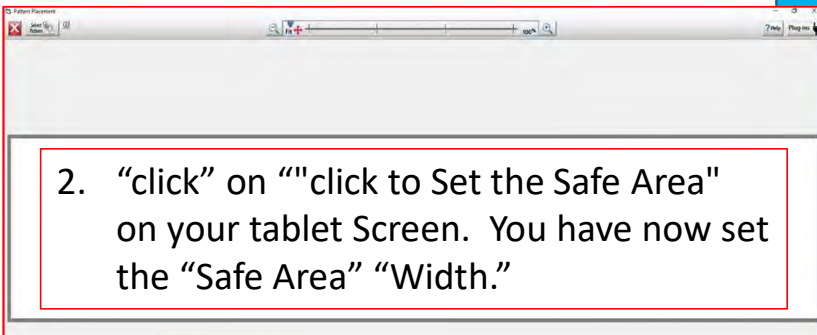
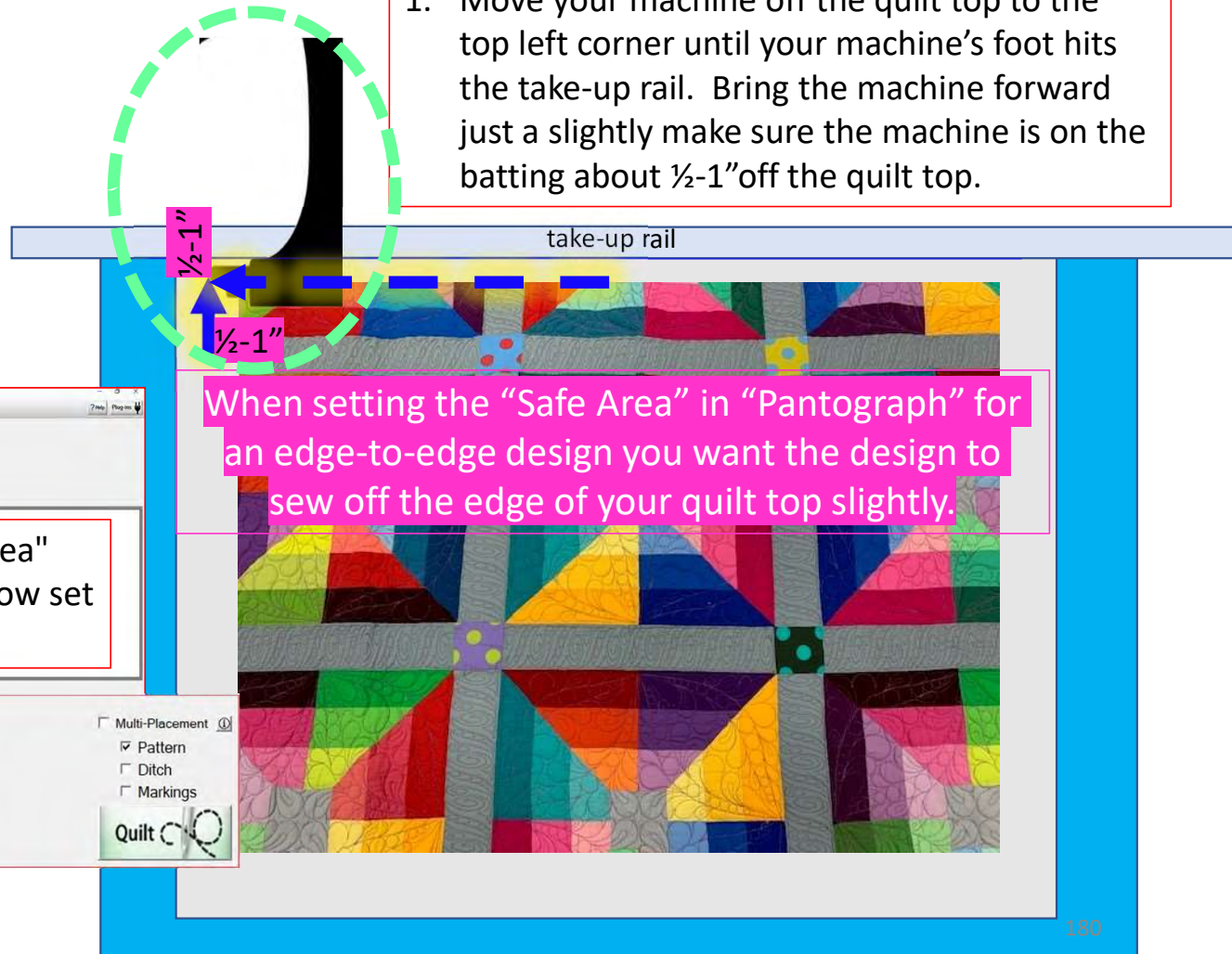

When setting the "Safe Area" in "Pantograph" for an edge-to-edge design you want the design to sew off the edge of your quilt top slightly.

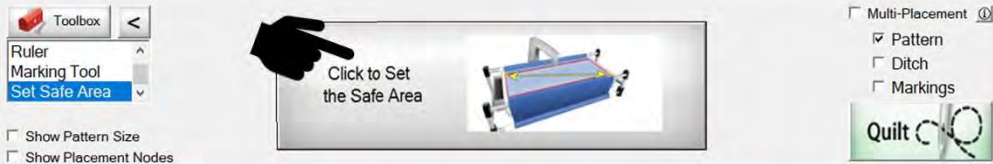

Quilting Interface continued. . . **Toolbox**

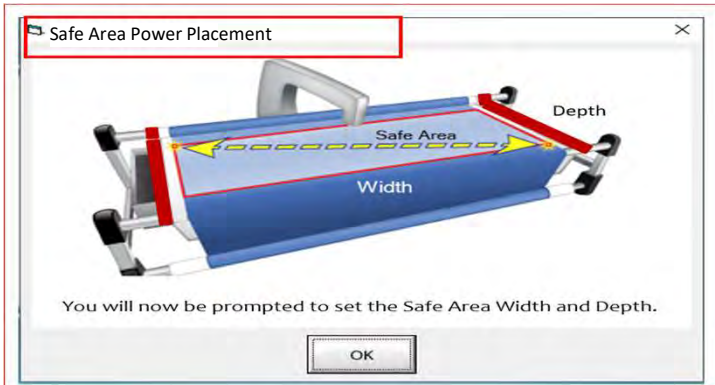

3. Move your machine the width of the quilt top off the right edge onto the batting about 1/2-1". Now bring move the machine as far forward as you can towards the front of the frame as far forward as the machine will extend to the "BOTTOM RIGHT."

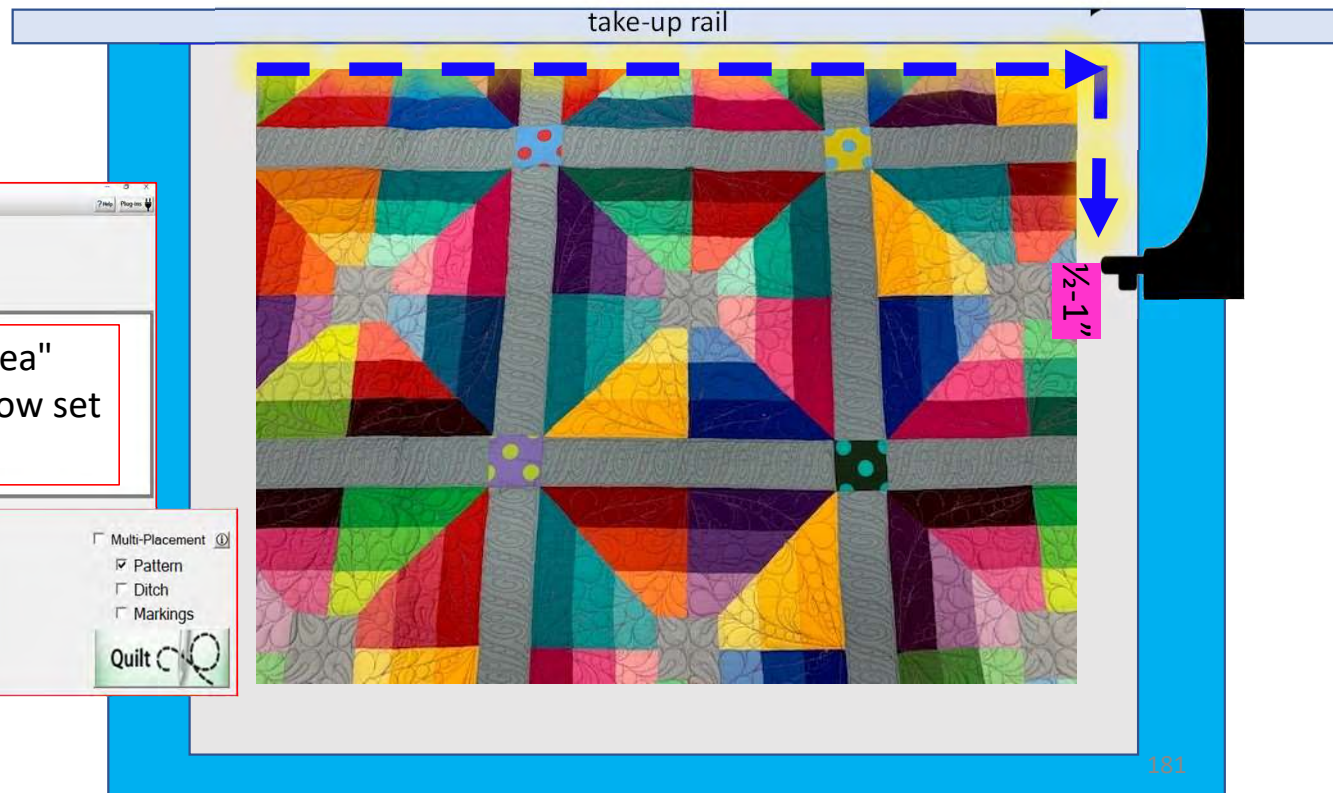

4. "click" on ""click to Set the Safe Area" on your tablet Screen. You have now set the "Safe Area" "Depth."



Quilting Interface continued. . . Toolbox

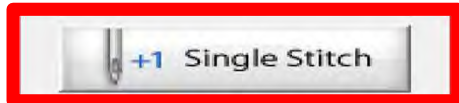

Single stitch to pull up bobbin thread

When you are in QuiltMotion mode your sewing machine functions are not available. The buttons on your machine do not work when QuiltMotion is engaged.

1. "Click" on "Single Stitch" the needle will insert down into the quilt to pull bobbin thread up. Another use for the "Single Stitch" is a tie off your thread.

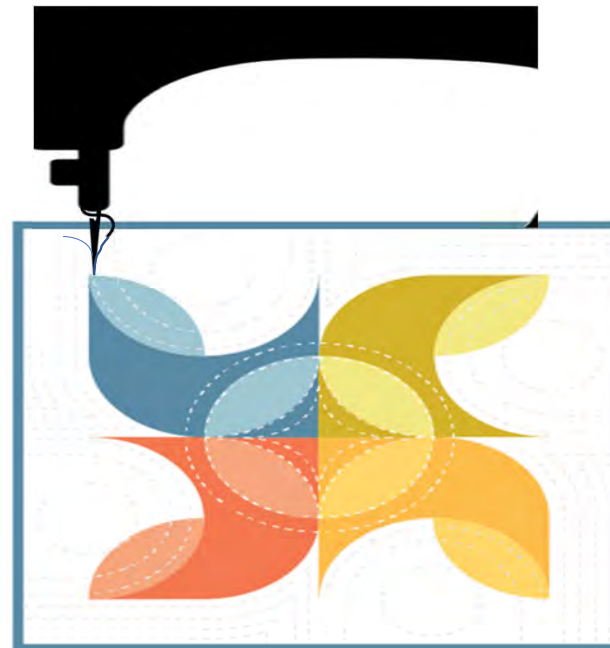

Quilting Interface continued. . . Toolbox

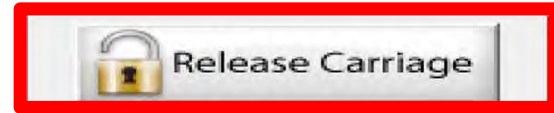

When using the QuiltMotion the carriage will be locked and can't be moved manually. However, there may be times you need to repair your design- like when run out of bobbin thread, or your thread breaks. "Click" on "Release Carriage" so you can move the sewing machine out of the way. Also use this option if you need to change the bobbin.



Quilting Interface continued. . . **Toolbox**



Quilting Interface - 0: USB not connected Safe Area: 60 x 30
File Help Debug

The ruler enables you to measure distances on your quilt. You can measure the length and width for borders, sashings, or blocks and find the center on those measurements. These measurements can be used to size your quilt top or block, to precisely place and quilt a design or pantograph.

Discover the many uses of the Ruler . . .

X will exit the ruler screen.

Ruler Functions
Quilt Width: 42.484

Back Release Carriage Apply Measurement

Length (in)
Total Stitches:
Sewn:
Remaining:
% Complete:



Ruler Screen Button and Functions

Ruler Functions
Quilt Width: 44.084



Takes you back to home screen



Toolbox



Place Measurement



Measure width distance between two (perfectly straight) points

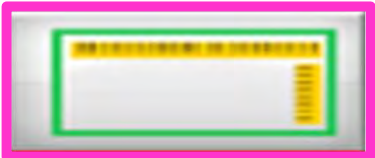

Measure width and depth area at the same time



Tape measure - measures the width between two points (it may not be perfectly straight)



Moves to the center of your measurement



Releases carriage so you can move it for placement or to move to the center of your measurement



Applies measurement to your "PantoStacker" screen

Quilting Interface Continued. . . **Toolbox**



End Point Adjust

“End Point Adjust” helps you refine your end points to match up before proceeding to the next zone. This is very helpful when you are quilting on a Hoop style frame.

Select Point

◻ ◀ First ◀ Prev 1 Next ▶ Last ▶ ◻

Show Selected Auto Move

Adjust Point

Small Steps
 Medium Steps
 Large Steps

← →

↑ ↓

Reset Current

Reset All

?

Cancel OK

Quilting Interface continued. . . **Toolbox**



End Point Adjust

Select Point

◻ ◀ First ◀ Prev 1 Next ▶ Last ▶ ◻

Show Selected Auto Move

Adjust Point

Small Steps
 Medium Steps
 Large Steps

← → Reset Current

↑ ↓ Reset All

[-] [0] [1] [2] [3] [4] [5] [6] [7] [8] [9] [+]

?

Cancel OK

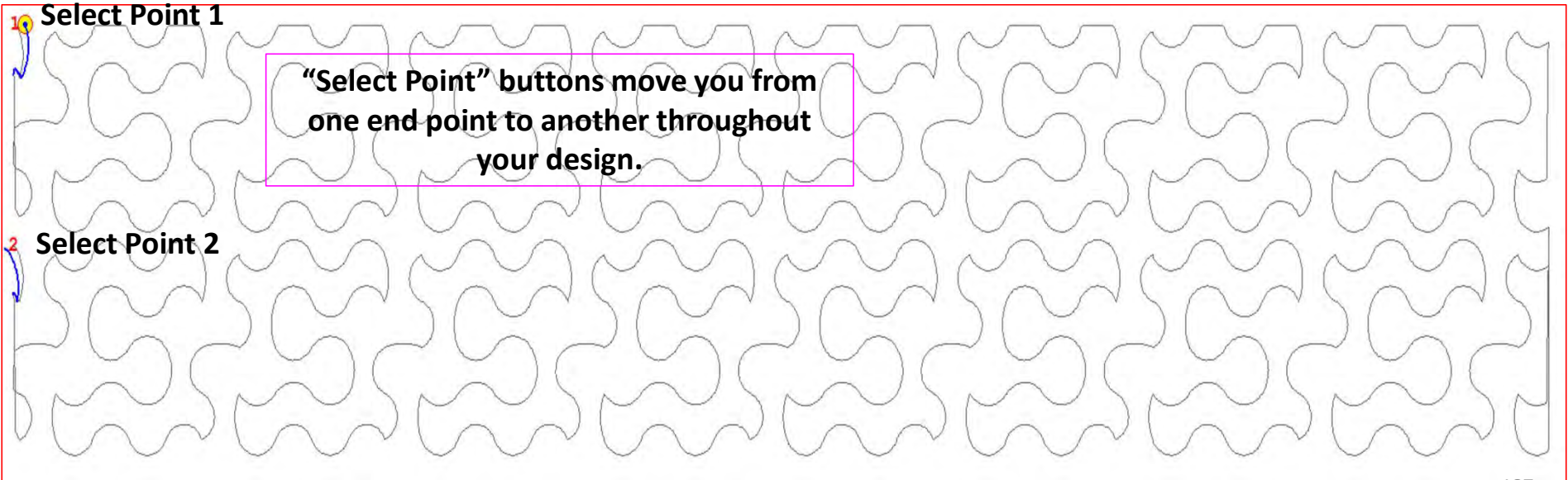

Quilting Interface Continued. . . Toolbox



End Point Adjust

Select Point

◻ ◀ First ◀ Prev 1 Next ▶ Last ▶ ◻

Show Selected Auto Move

Adjust Point

Small Steps
 Medium Steps
 Large Steps

← → Reset Current
↑ ↓ Reset All

[-] [] ? Cancel OK

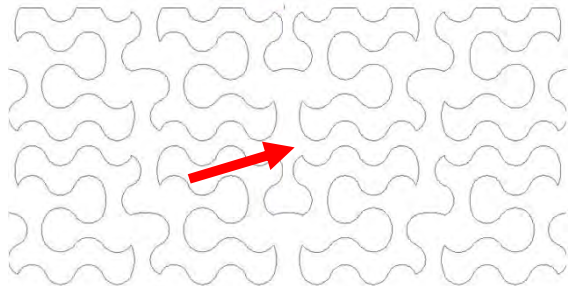
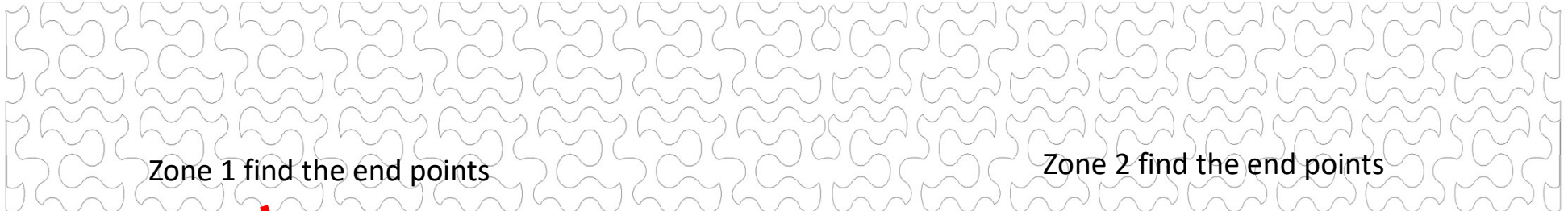

“Adjust Point” buttons help you adjust the end point of last zone with the beginning point of a new zone. To adjust the end point click on the “Nudge Arrows” the direction you need it adjusted use small, medium or large steps to match up the end point to the start point. Matching up the points as close as possible will help your design look like one continuous design. Use the “Reset” to undo adjustments.

Quilting Interface Continued. . . Toolbox



End Point Adjust

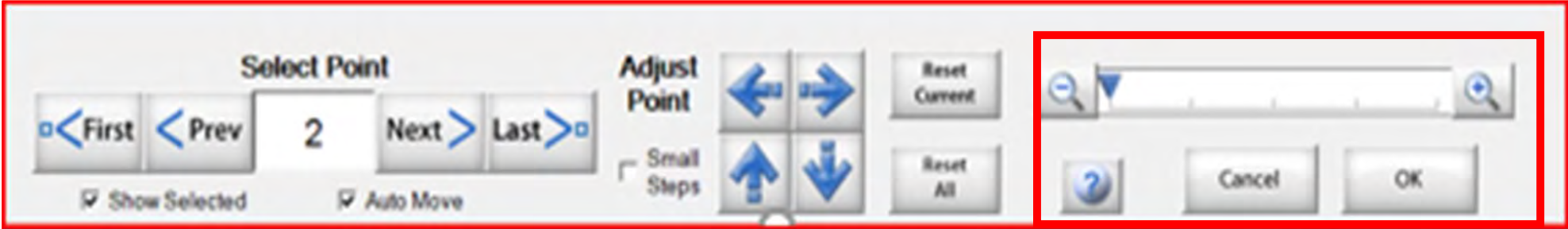

The toolbar includes the following elements:

- Select Point:** Buttons for < First, < Prev, 2 (selected), Next >, Last >. Below are checkboxes for Show Selected and Auto Move.
- Adjust Point:** Four directional arrow buttons (left, right, up, down) and a Small Steps checkbox.
- Reset:** Buttons for Reset Current and Reset All.
- Zoom:** A zoom slider with magnifying glass icons at both ends.
- Help/Action:** A question mark icon, a Cancel button, and an OK button.

“Zoom In” Enlarges your design to help you with accuracy on your adjustments.

Zone Placement

Takes you back to the Quilting Interface screen.

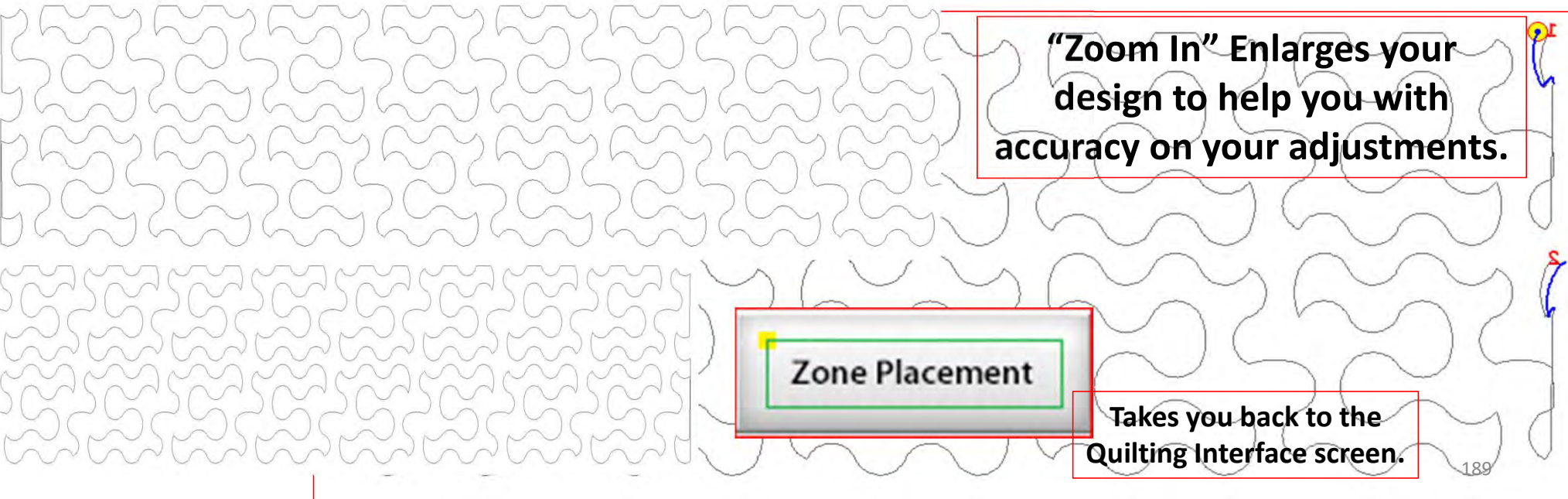

Quilting Interface continued. . . **Toolbox**

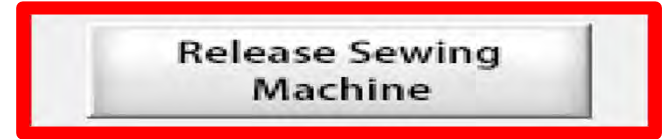

“Click” on “Release Sewing Machine” to take control of your machine manually. This allows you to check your machine’s functions to make sure it is sewing correctly.

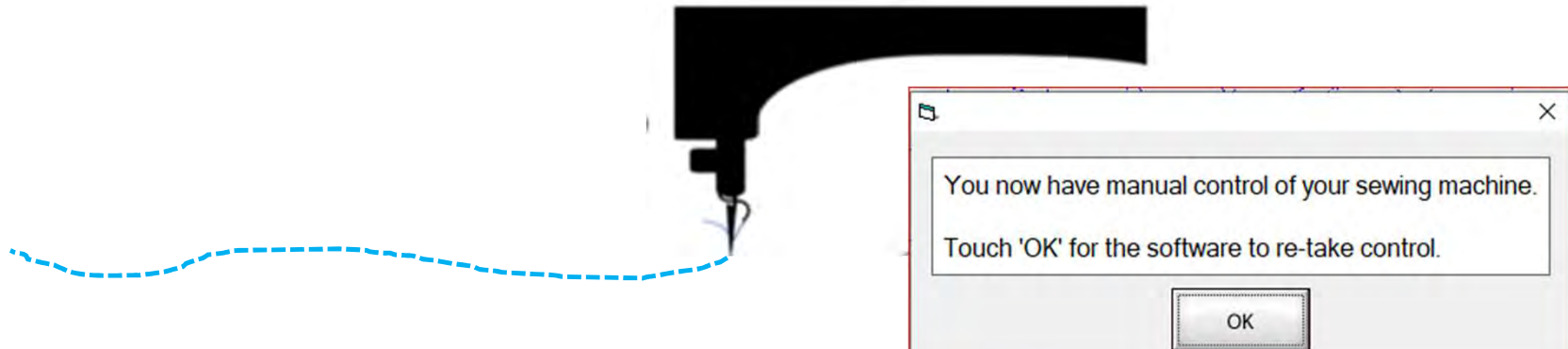

DO NOT "click" OK UNTIL YOU ARE READY FOR QUILTMOTION TO REENGAGE.

Quilting Interface continued. . . **Toolbox**

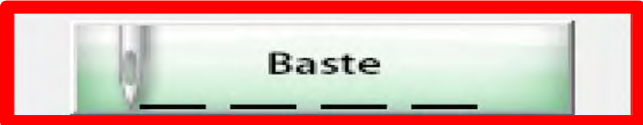

1. "Click" on "Slow Baste." Move your machine across the area you want to baste. The slower you move the machine across your quilt the smaller and closer together. The stitches will be. The faster you move your machine, the larger and further apart the stitches are.

2. "Click" on "Stop" when finished.

The higher the speed the faster the needle down/up is.

1 The Basting Tool

Speed 1

Slow Baste

+1 Single Stitch

Exit

'Single Stitch' is provided for pulling the bobbin thread.

2 The Basting Tool

Speed 1

Stop

Exit

'Single Stitch' is provided for pulling the bobbin thread.

The Basting Tool

Speed 5

Slow Baste

+1 Single Stitch

Exit

'Single Stitch' is provided for pulling the bobbin thread.

Quilting Interface continued. . . Repair Pattern

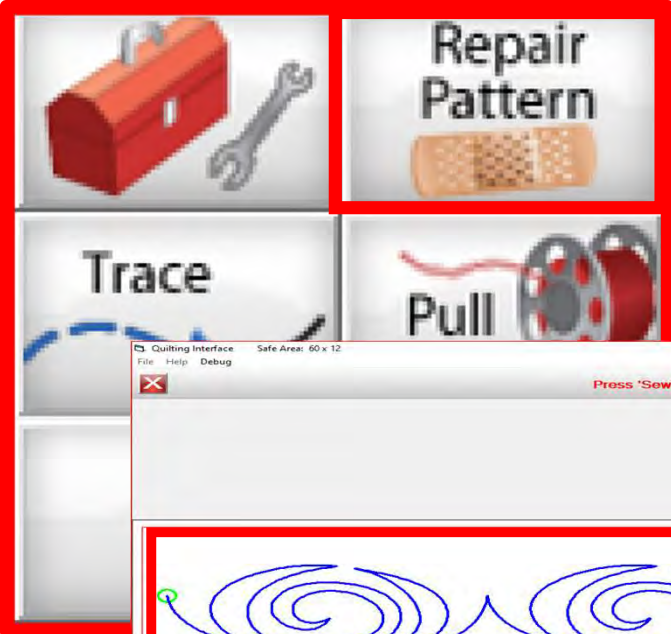

“Repair Pattern” is here to help you repair your design when your thread breaks’ or the bobbin thread runs out. Let me show you how to use these tools to repair your quilting design.

Press 'Sew' to resume...

Quilted portion of design, stopped we need to repair the design before proceeding on.

Sew Resume Press 'Sew' to resume sewing. (Prior to sewing, alignments or bobbin pulls may be performed.)	Sew	Finished! Placement Repair Pattern	Length (m) 296 Total Stitches 2995 Sewn: 1776 Remaining: 1219 % Complete: 59
---	------------	--	--

Click on "Repair Pattern"

Quilting interface continued. . . **Repair Pattern**

The “Repair Pattern” tools help you easily repair your design and make it look like you never stopped to repair it.

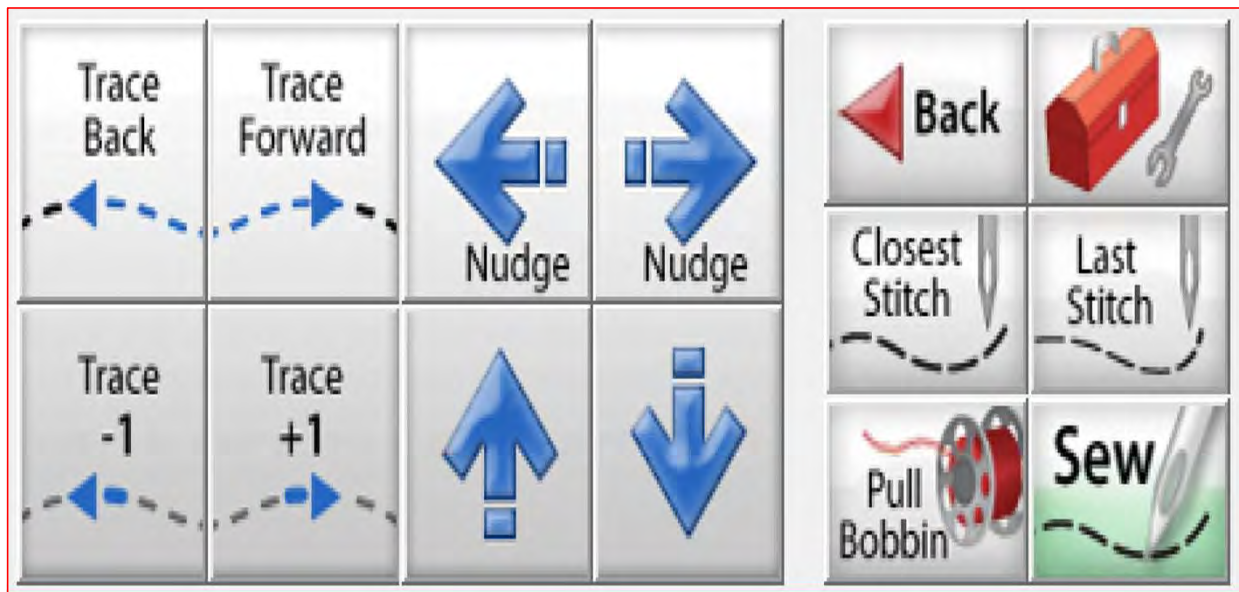

Quilting Interface continued. . . **Repair Pattern**

Trace Back and Trace Forward to where you position the machine on the design.

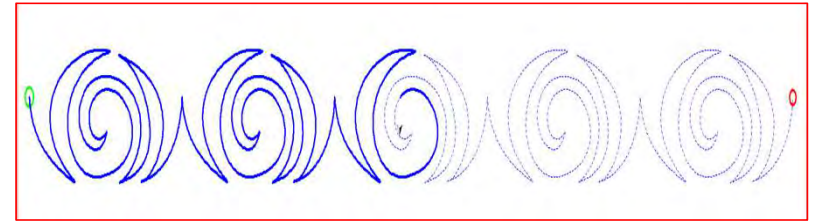
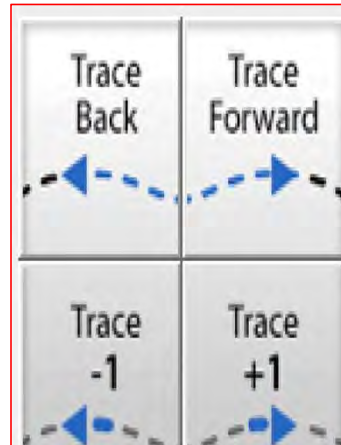
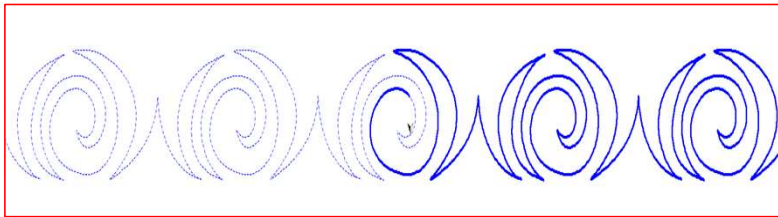

Trace (-1) or (+1) traces forward or backward one stitch at a time.

“Trace,” traces over your already quilted design without the sewing machine sewing. The “Trace” features allows you to trace forward or backward to find exactly where the design stopped sewing. Finding the stitch you stopped sewing allows you start stitching seamlessly, so your design has no breaks in your stitches from where it stopped.

Quilting interface continued. . . **Repair Pattern**



Move your machine to the last stitched, stitch then click on “Closest Stitch.” Moving the machine near that last stitched portion of the design helps the automation find that location on the design and when you click on “Closest Stitch” it will find the nearest stitch in you design.

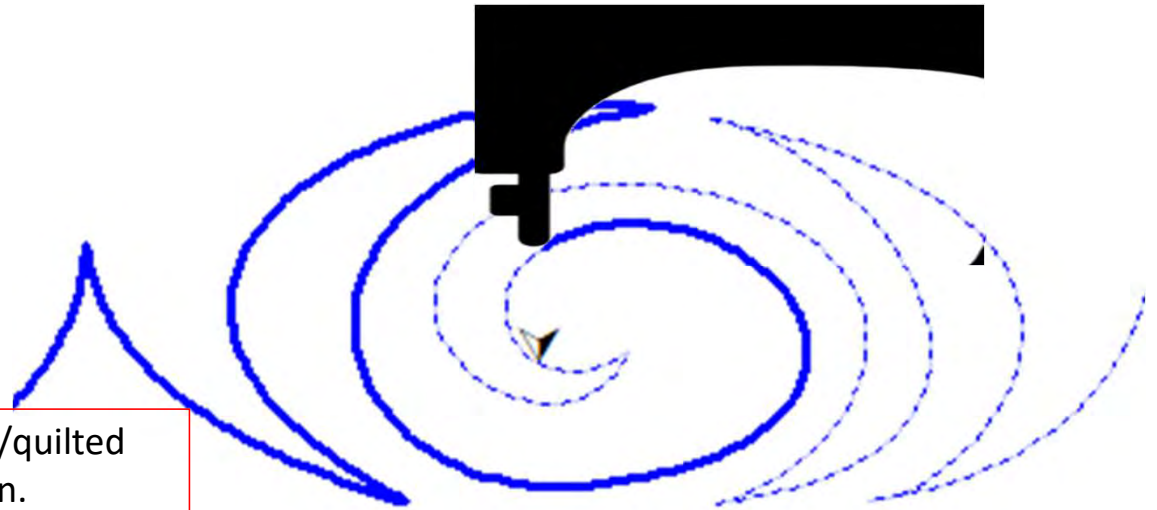

Solid blue line is the sewed/quilted portion of your design.

Quilting interface continued. . . **Repair Pattern**



“Last Stitch” will take you to the last stitch, stitched on you design. This is where the sewing machine stopped. If the thread broke or you ran out of bobbin the sewing machine will keep stitching until you hit stop.

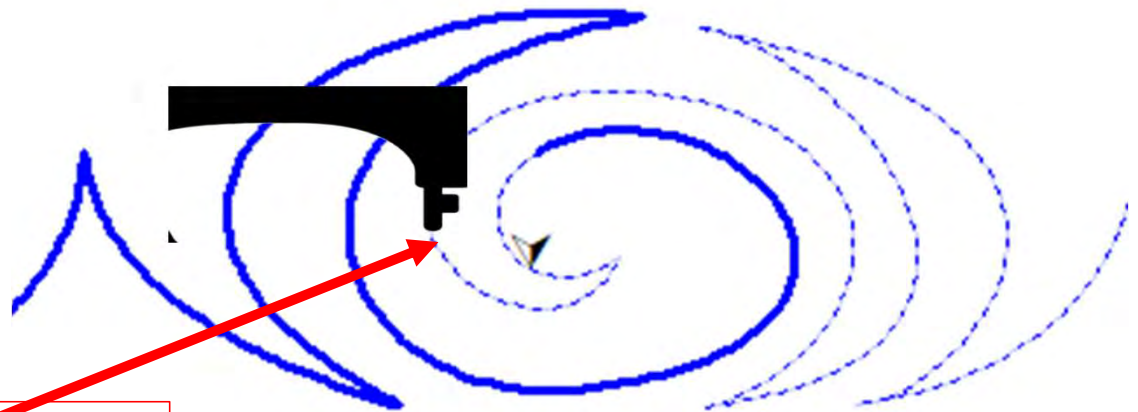

Sewing machine stopped.

Quilting interface continued. . . **Repair Pattern**

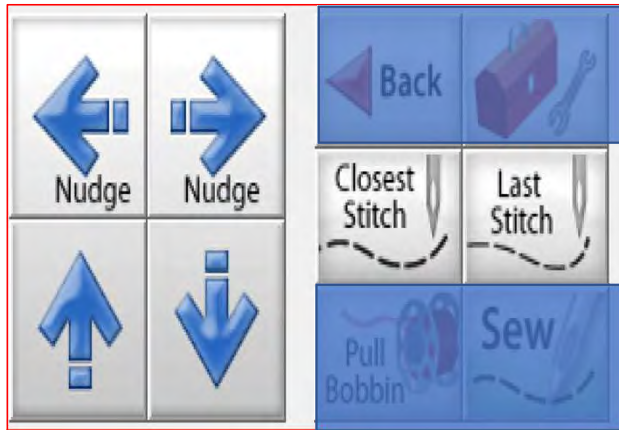

Sometimes your machine might need a little “Nudge” to help it get back exactly to where you stopped stitching. If your thread broke, or your bobbin ran out and your machine kept sewing without stitching. Click on “Last Stitch” your machine will move to the last place it stopped sewing. Notice you don’t have stitches, use the “Nudge” buttons to get you to the last stitched stitch.

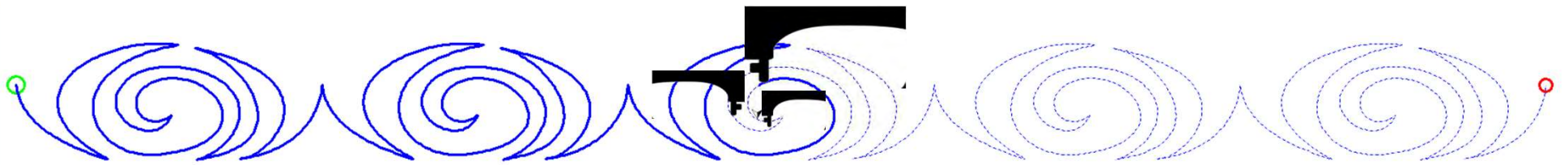

Using the “Nudge” arrows you can move the machine in small increments to where it stopped stitching.

Quilting interface continued. . . **Change Bobbin**

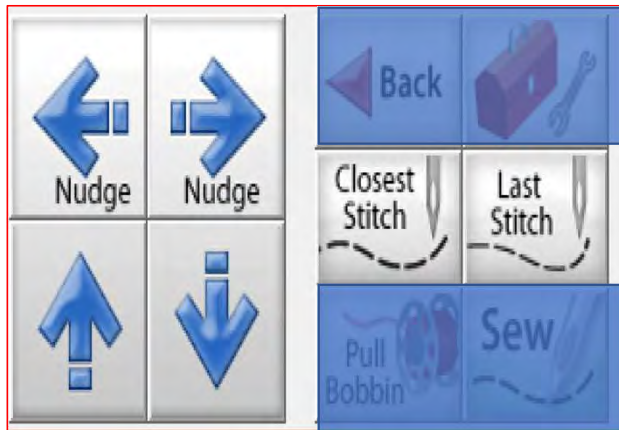

Click on the “**Toolbox**” and then Click on “**Release Carriage**” inside the toolbox. Once the carriage is released move it to the side of your quilt and change the bobbin. After the bobbin is changed move the machine back to the last stitch that was stitched in your design. Click on “**Closest Stitch**” when you click on closest stitch your machine will engage with the automation and lock onto that stitch in the design, if your needle is in the right location on your design click on “**Pull Bobbin.**”

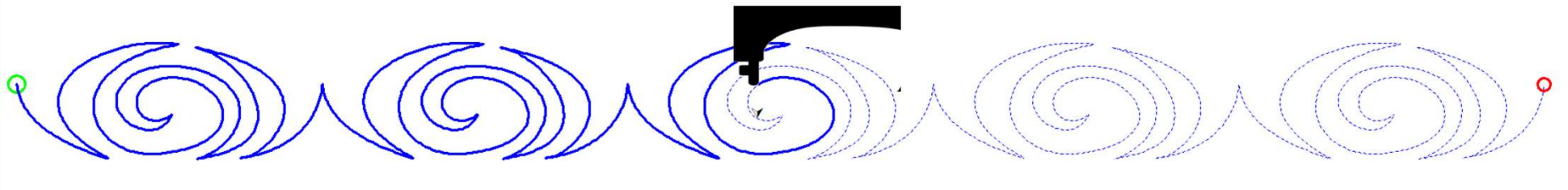

Pull your bobbin thread and then click on “**Sew**” to finish quilting your design. Your machine will sew your t
offs and continue sewing/quilting the rest of your design. Once it has stopped Click on “**Finished Pattern,**”
and pull your bobbin thread up.