

Cutie Tabletop Fabric Frame Channel Lock Instructions

Use

Channel locks can help you stitch straight lines by either holding the bottom carriage in place on the frame or holding the top plate or machine in place on the bottom carriage. Note the differences in between the channel locks to make sure you use the correct ones and install them in the correct places.

Required Parts and Tools

**Cutie Bottom
Channel Lock**

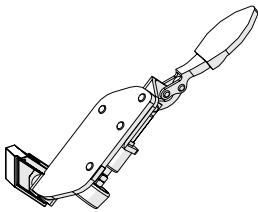

ACC-09-15587

**Cutie Top
Channel Lock**

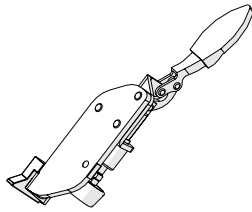

ACC-09-15584

Top Channel Lock

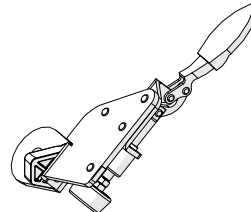

ACC-09-13057

**SBHCS
M6 x 20 mm**

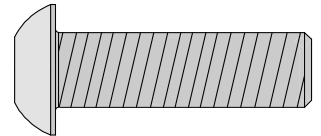

HDW-03-10088

**SBHCS
M6 x 16 mm (x2)**

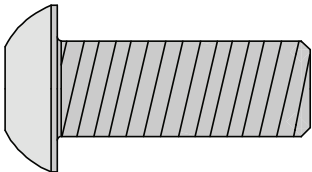

HDW-03-10974

Allen Wrench 4 mm

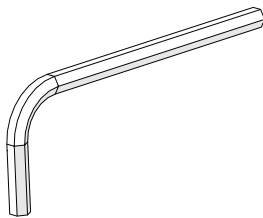

HDW-03-10167

Needle-Nose Pliers

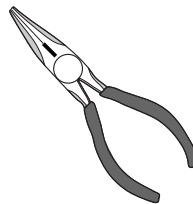

(not included)

Cutie Frame

Install the Cutie Bottom Channel Lock

Parts and Tools Needed

Cutie Bottom Channel Lock

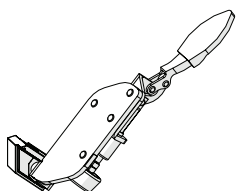

**SBHCS
M6 x 16 mm (x1)**

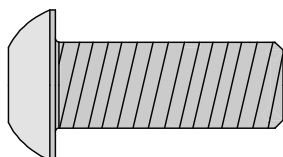

**Allen Wrench
4 mm**

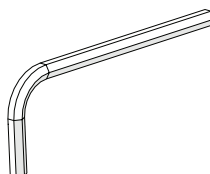

Instructions

Take the following steps to install the Cutie bottom channel lock to the bottom carriage.

- 1 Find the **sticker** identifying the rear of the bottom carriage to locate the the right rear **wheels**.

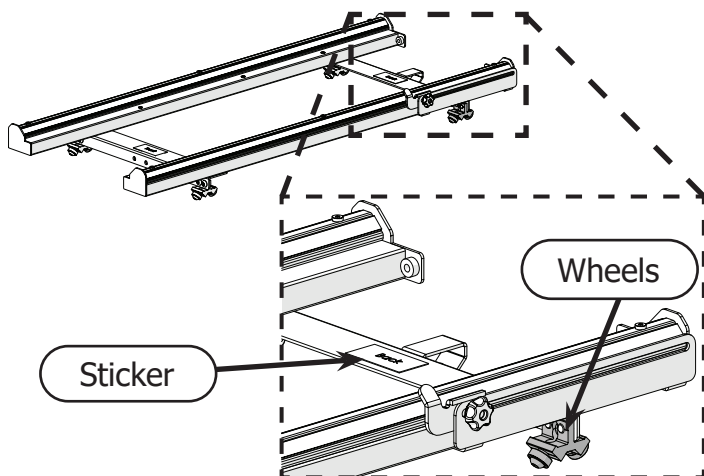

- 2 Use a 4 mm Allen wrench to remove the **wheel screw, rear facing wheel, and wheel spacer**.

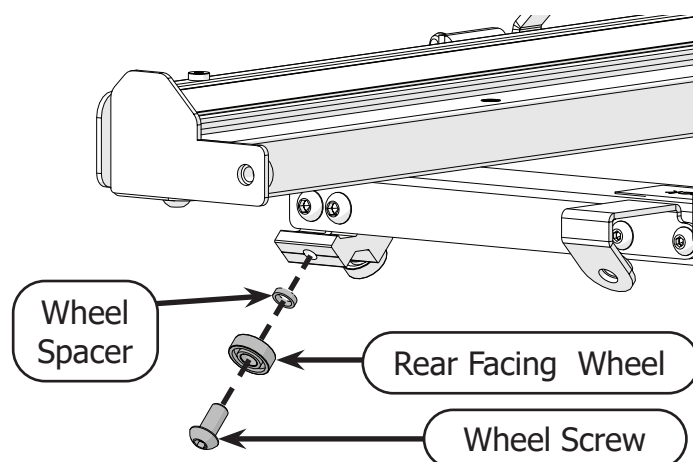

- 3 Use the **M6 x 16 mm SBHCS** to attach the **Cutie bottom channel lock, wheel, and wheel spacer**. Tighten with the 4 mm Allen wrench.

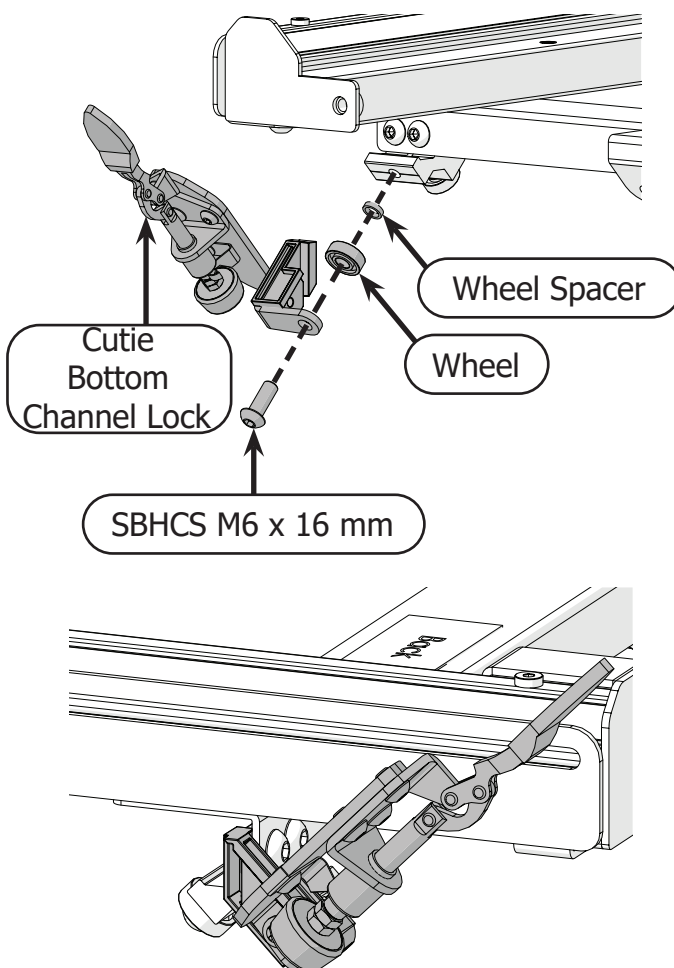

Install the Cutie Top Channel Lock

Parts and Tools Needed

**Cutie Top
Channel Lock**

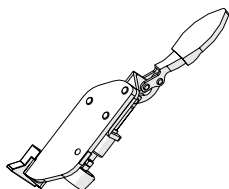

**SBHCS
M6 x 16 mm (x1)**

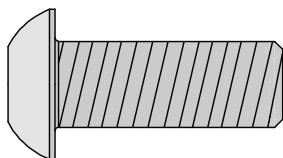

**Allen Wrench
4 mm**

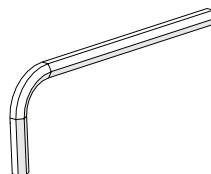

Instructions

If you are using the Cutie Frame Top Plate and a home sewing machine, take the following steps to install the Cutie top channel lock to the top plate.

- 1 Locate the top plate's right rear **wheels**.

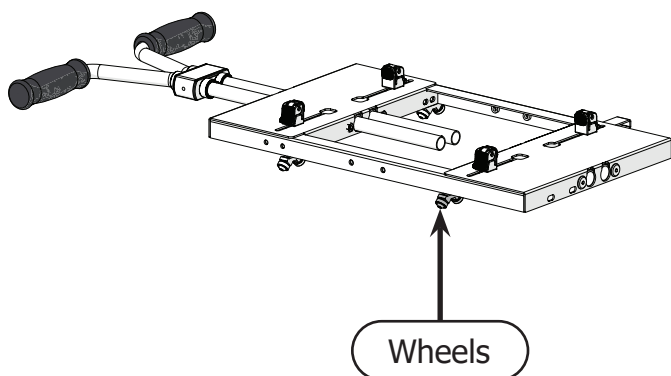

- 2 Use a 4 mm Allen wrench to remove the **wheel screw, outward facing wheel, and wheel spacer**.

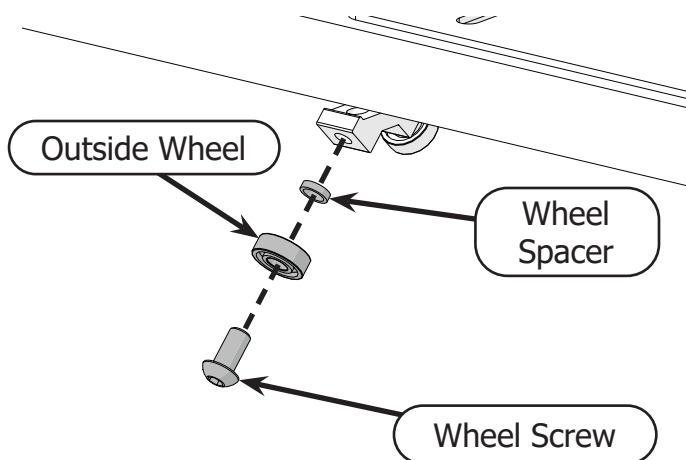

- 3 Use the **M6 x 16 mm SBHCS** to attach the **Cutie Top channel lock, wheel, and wheel spacer**. Tighten with the 4 mm Allen wrench.

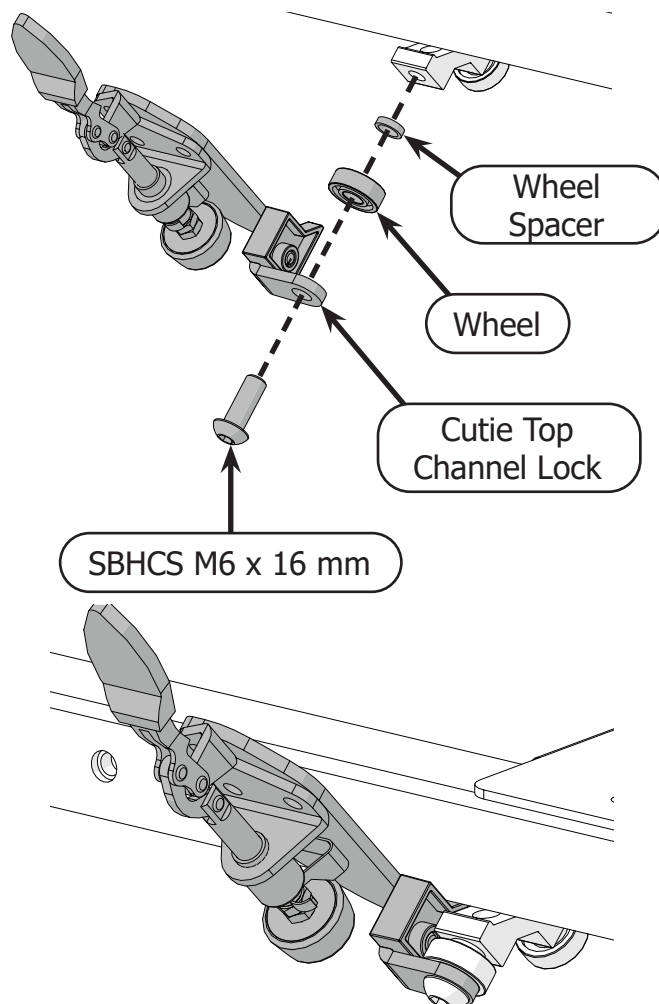

Cutie Frame

Install the Top Channel Lock

Parts and Tools Needed

Top Channel Lock

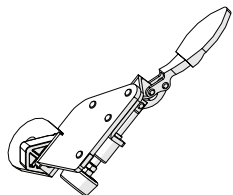

SBHCS
M6 x 20 mm

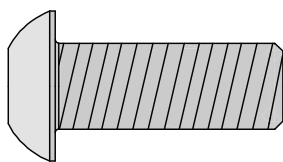

Allen Wrench
4 mm

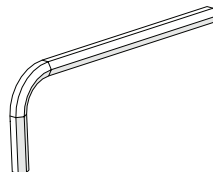

Instructions

If you are using a quilting machine instead of the Cutie Frame Top Plate, take the following steps to install the top channel lock to your machine.

- 1 Locate the machine's right rear **wheels**.

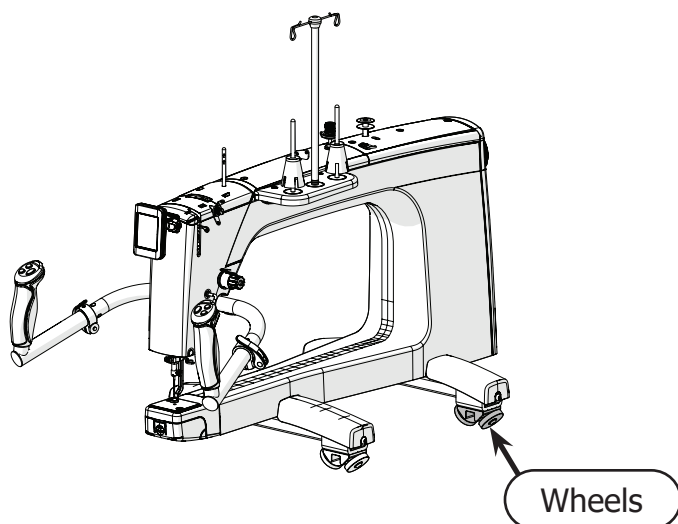

- 2 Use a 4 mm Allen wrench to remove the **outside wheel** and **wheel screw**.

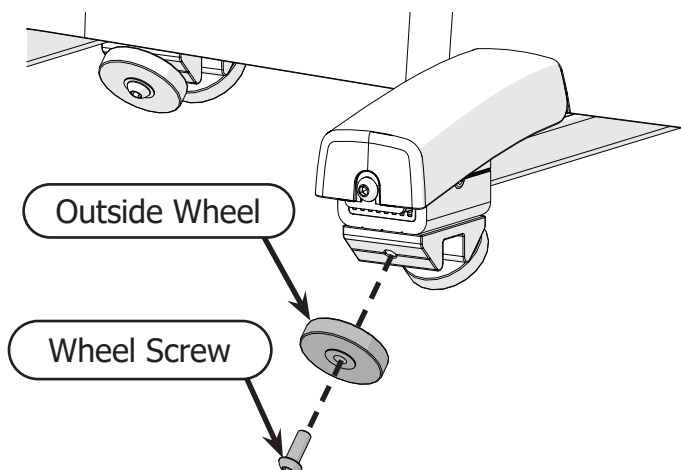

- 3 Use the **M6 x 20 mm SBHCS** to attach the **top channel lock** and **wheel**. Tighten with the 4 mm Allen wrench.

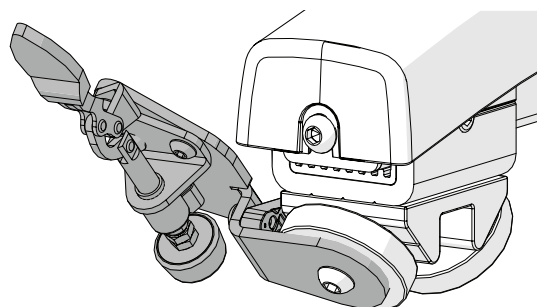
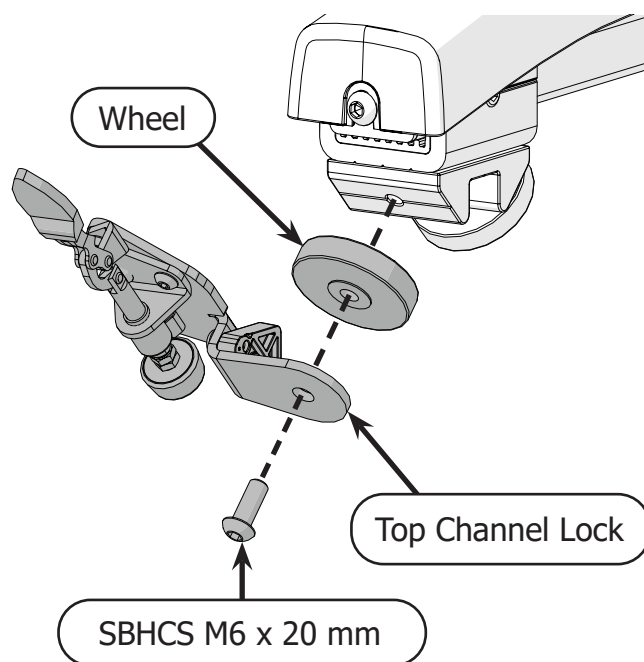

Use the Channel Locks

Parts and Tools Needed

Needle-Nose Pliers

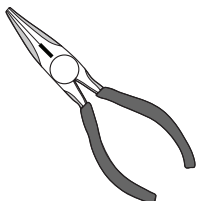

Instructions

Take the following steps to use the channel locks to inhibit the movement of the bottom carriage, machine, or top plate.

- 1 Turn the **handle** of the channel lock down completely.

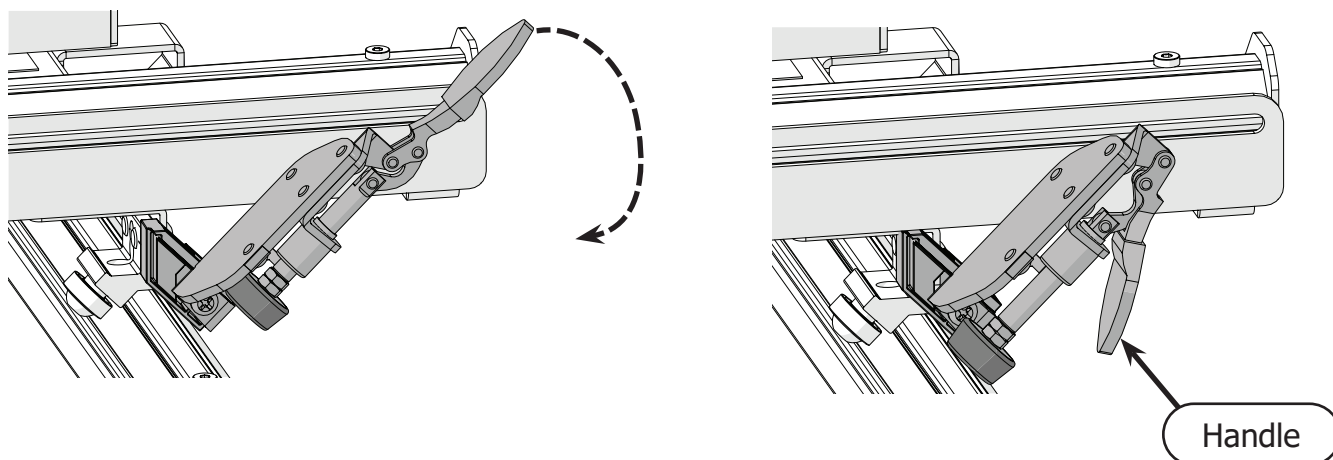

- 2 If the rubber foot does not push against the track, twist it counter-clockwise to extend it until it does.

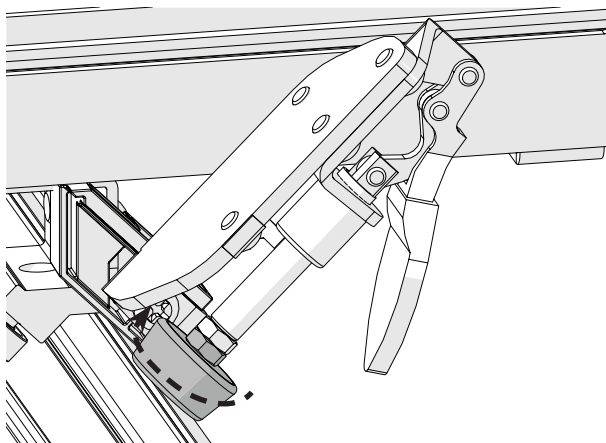

Cutie Frame

- 3 To prevent the channel lock from loosening over time, use needle-nose pliers to tighten the bottom **4 mm hex** nut against the rubber foot. Tighten the other hex nut against the **channel lock barrel**.

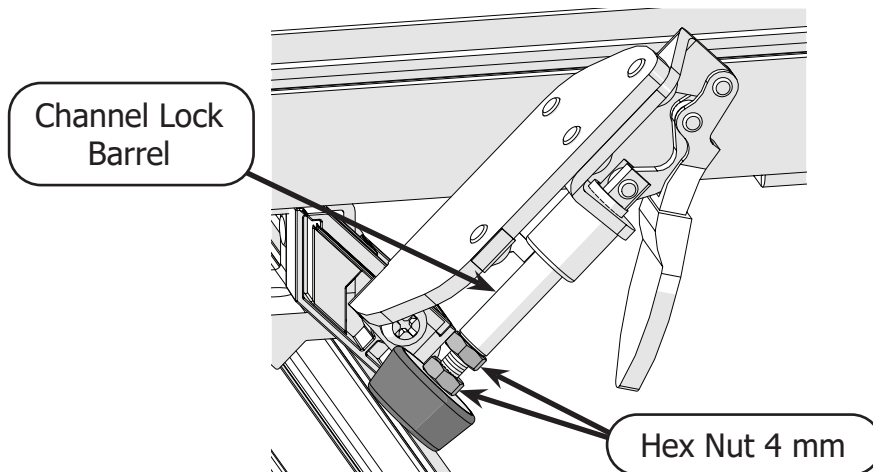

- 4 Use the top channel lock to hold the top plate or machine in place and stitch straight from right to left.

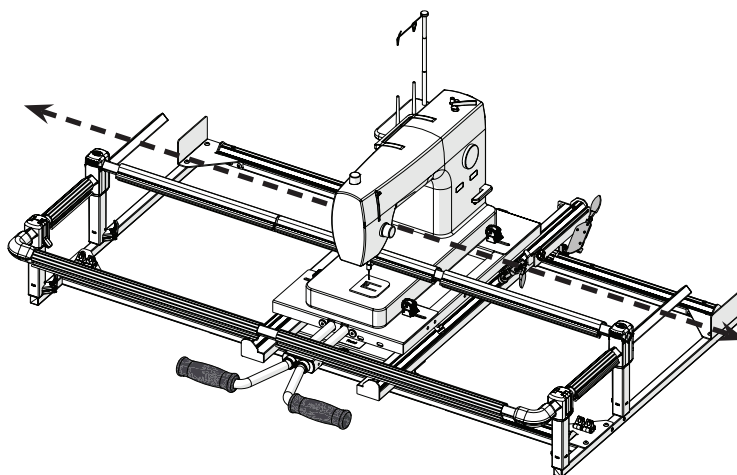

- 5 Use the bottom channel lock to hold the bottom carriage in place and stitch straight from front to back.

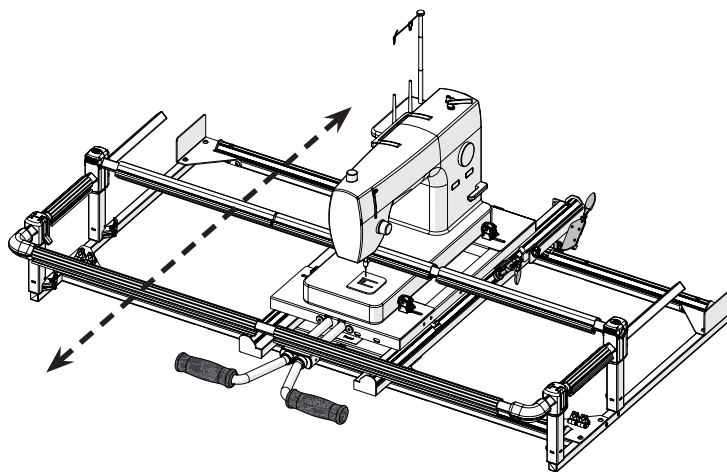

- 6 Open both channel locks to resume unrestricted quilting.

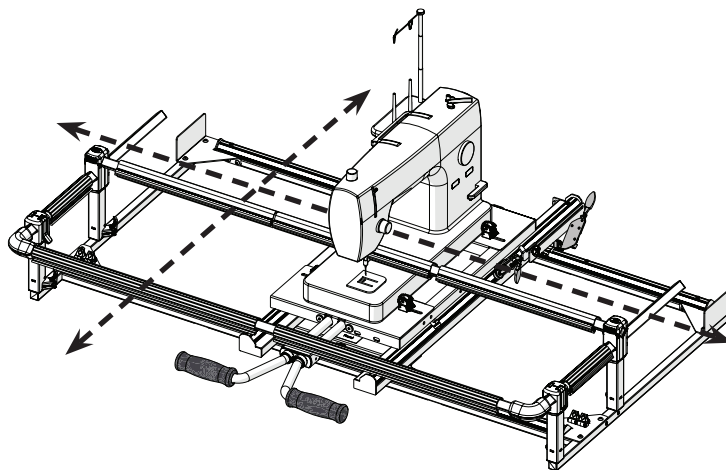

The Grace Company
Phone: 1-800-264-0644
www.graceframe.com

